

# CR TYPE

— Standard Curved Roller Cage —

part number structure

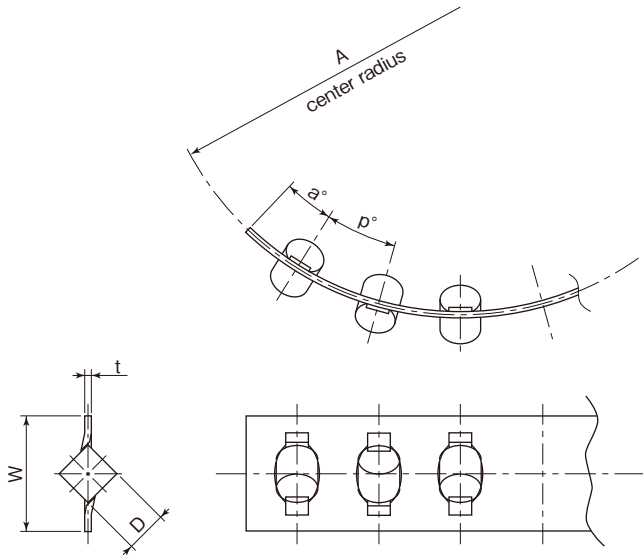
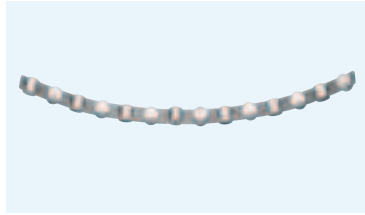
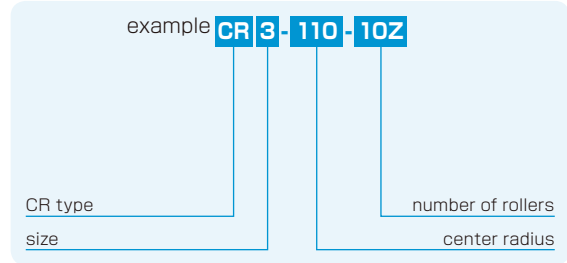

part number	roller diameter		center radius		t mm	w mm	p°	a°	applicable type
	D mm	A mm							
CR2- 50- 7Z	2	50	0.3	5.6	0.3	5.6	4.6°	2.9°	RV
CR2- 60-12Z		60					3.8°	2.4°	RV
CR2- 70-10Z		70					3.3°	2.0°	RVF
CR2- 87-10Z		87					2.6°	1.6°	RVF
CR2-103-10Z		103					2.2°	1.4°	RVF
CR2-120- 9Z		120					1.9°	1.2°	RVF
CR3- 85-10Z	3	85	0.4	7.2	0.4	7.2	3.4°	2.9°	RVF
CR3- 90-11Z		90					3.2°	1.9°	RV
CR3-110-10Z		110					2.6°	1.5°	RVF,RV
CR3-125-16Z		125					2.3°	1.3°	RVF
CR3-160-14Z		160					1.8°	1.0°	RVF,RV

# ACTUATOR

# ACTUATOR

NB's BG type is a compact single axis actuator which integrates a slide guide and precision ball screw. BG type offers compact dimensions and outperforms conventional positioning tables.

This is made possible by a unique "U" shaped guide rail and slide block which provides multiple functions of a guide block and a ball screw nut combined into a single unit. The "U" shaped guide rail offers high rigidity against bending moment. This structural feature allows for integrated framework of machinery or equipment and can be cantilevered. Additionally, the slide block contains 4 ball circuits which delivers high load capacity, high accuracy and high rigidity.

Figure H-1 Structure of BG type

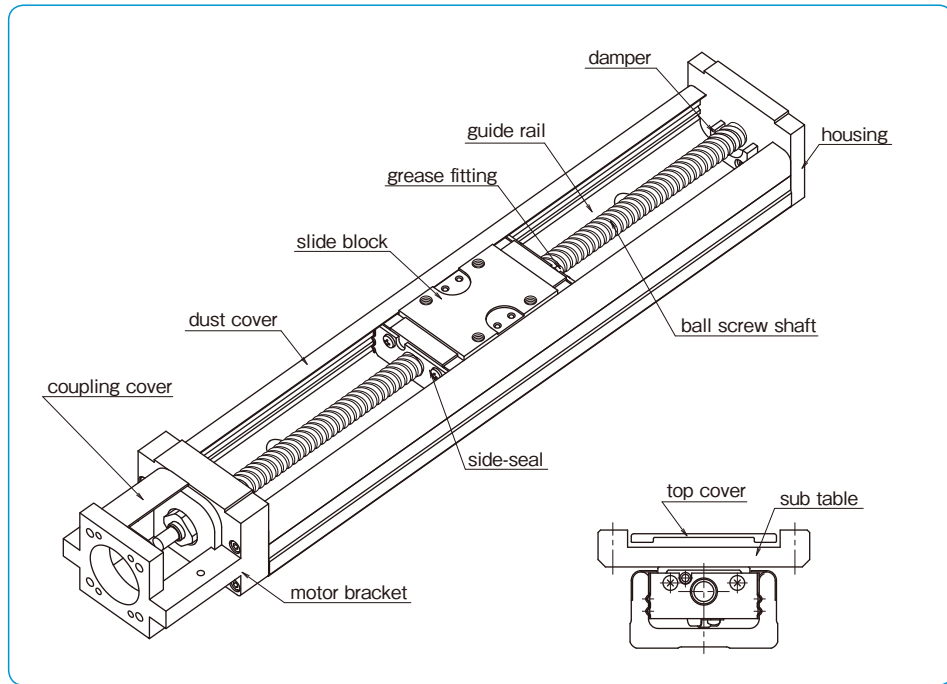

## ADVANTAGES

### Adjustment Free

The integration of the slide guide and precision ball screw eliminates complex precision adjustment and reduces installation time dramatically.

### High Rigidity

"U" shaped guide rail provides very high rigidity despite its compact configuration and can be used for cantilevered application. (refer to page H-9)

### High Accuracy

BG type contains four ball circuits and four-point contact ball grooves which contribute to its high rigidity. The combination of precision ground guide rail, slide block and precision ball screw provides high positioning accuracy.

### Space Saving

In comparison to conventional positioning tables, the BG type allows for compact designs and dramatic space saving. The "U" shaped guide rail and integrated slide block and precision ball screw make this possible.

Figure H-2 Ball Contact Profile

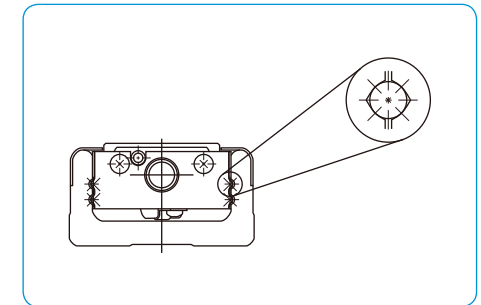
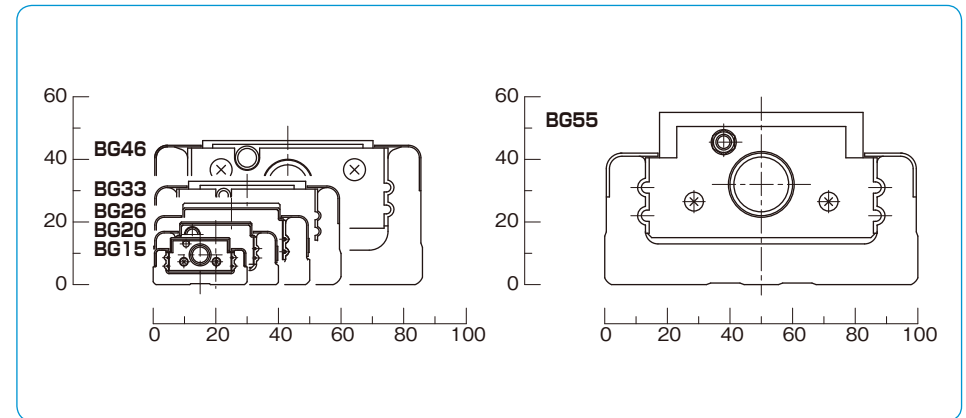

Figure H-3 Cross Section



PART NUMBER STRUCTURE

Part number for BG type is described as follows.

① BG type  
 BG 15 01 A / 02 B

② size  
 75 H / 100 P / 125 / 150 / 175 / 200

③ ball screw lead  
 A0 / A1 C / A2 J / A3 J / A4 / A5 / A6 / A7 / A8 / A9 / AA / RO

④ type of block  
 A 1 long block  
 B 2 long blocks  
 C 1 short block  
 D 2 short blocks

⑤ guide rail length  
 100 H / 150 P / 200

⑥ accuracy grade  
 H high grade  
 P precision grade

⑦ motor bracket (refer to page H-17~)  
 The number in the square, □, after suffix RA, RB or RC indicates the mounting direction code. (refer to page H-32, H-33)

⑧ cover and bellows  
 none without top cover  
 C with top cover + sub table  
 J○○ with bellows

⑨ sensor  
 none without sensor  
 S with slim-type / compact photomicro sensor  
 H with close contact capable photomicro sensor  
 K with proximity sensor

⑩ option  
 none without option  
 P△□ with positioning pin hole (※1)  
 G▲ with special grease option (※2)  
 LB with low temperature black chrome treatment (※3)  
 PNP with PNP sensor

In case of multiple options, add + between each option.  
 Example: (PS+LB+PNP)  
 ※1: △ is S, W or R (refer to page H-57)  
 □ is R (refer to page H-57)  
 ※2: ▲ is K, U, L or F (refer to page H-16)  
 Grease is applied to slide guide, ball screw, and angular bearings.  
 ※3: LB is applied to steel parts except for aluminum parts and radial bearings.  
 For BG15, LB is applied to steel parts except for the drive block, aluminum parts, and radial bearings.  
 Black chrome treatment is applied to the drive block.

SPECIFICATIONS

BG Type is categorized as either high grade (H) or precision grade (P).

Table H-1 Specifications

part number	BG1501	BG1502	BG2001	BG2005	BG2602	BG2605	BG3305	BG3310	BG3320	BG4610	BG4620	BG5520									
precision grade	high	precision	high	precision	high	precision	high	precision	high	precision	high	precision									
radial clearance	μm -2~0 -4~-2 -2~0 -4~-2 -3~0 -6~-3 -3~0 -6~-3 -4~0 -8~-4 -4~0 -8~-4 -3~0 -7~-3 -3~0 -7~-3 -3~0 -7~-3 -5~0 -11~-5 -6~0 -18~-6																				
guide	long block	basic dynamic load C	kN		2.42	4.27		7.87		12.6		29.8		43.2							
		basic static load Co	kN		4.76	7.89		14.98		22.7		51.2		74.0							
		allowable static moment	M <sub>1</sub>	N·m		17	35		99		181		610		1,088						
			M <sub>2P</sub>	N·m		92	199		550		1,035		3,285		5,465						
			M <sub>2V</sub>	N·m		20	42		118		215		727		1,297						
	M <sub>2R</sub>		N·m		110	237		656		1,233		3,914		6,513							
	short block	basic dynamic load C	kN		—	—		—		7.8		—		19.9		—					
		basic static load Co	kN		—	—		—		11.4		—		28.8		—					
		allowable static moment	M <sub>1</sub>	N·m		—	—		—		49		—		207		—				
			M <sub>2P</sub>	N·m		—	—		—		368		—		1,336		—				
M <sub>2V</sub>			N·m		—	—		—		59		—		246		—					
M <sub>2R</sub>	N·m		—	—		—		439		—		1,593		—							
ball screw	shaft diameter	mm		6		6		8		10		12		15		20					
		mm		1	2	1	5	2	5	5	10	20	10	20	20						
	spacer-ball ratio	—		—		—		—		—		1:1		1:1		1:1		2:1			
		basic dynamic load Ca	kN		0.39	0.54	0.63	0.65	2.60	2.35	3.35	2.11	2.20	1.39	2.32	1.46	4.40	2.77	4.40	3.36	5.40
	basic static load Coa	kN		0.77	0.75	1.34	0.92	3.64	3.30	5.90	2.95	3.50	1.75	4.05	2.02	7.90	3.95	7.90	5.27	10.5	7.00
	bearing support	part number	—		AC4-12DF		AC5-14DF		AC6-16DF		70M8DF/GMP5		7001T2DF/GMP5		7002T2DF/GMP5		—				
		basic dynamic load Cb	kN		1.21		1.31		1.79		4.40		6.77		7.74		—				
		basic static load Cob	kN		1.08		1.25		1.76		4.36		7.45		9.50		—				

M<sub>2P</sub>, M<sub>2V</sub> and M<sub>2R</sub> are the allowable static moments when 2 blocks are used in close contact.  
 ※ Please consult with NB when using BG15, BG20 and BG26 series in the Precision grade with short and frequent stroke. (short stroke: BG1501= 2mm or less, BG1502= 4mm or less, BG2001 = 7mm or less, BG2005 = 25mm or less, BG2602 = 14mm or less and BG2605 = 25mm or less)  
 Short blocks are not available for BG3320.

Figure H-4 Direction of Moment

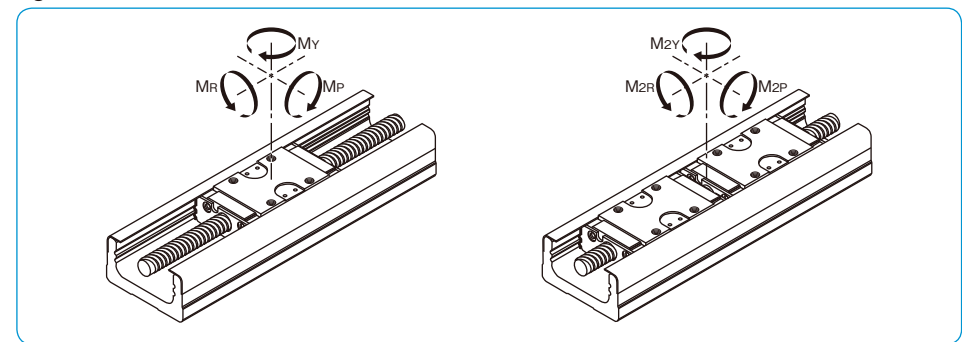

ALLOWABLE SPEED

Allowable speed of BG type is subject to the type of motor and operating conditions. The speed may also be limited by the critical speed of the ball screw. Use caution when operating at high speeds or using long rails.

Table H-2 Allowable Speed

part number	rail length mm	speed mm./sec	part number	rail length mm	speed mm./sec	part number	rail length mm	speed mm./sec	part number	rail length mm	speed mm./sec
BG1501	75	185	BG3305	150	550	BG4610	340	740	BG5520	980	1,120
	100			200			440			1,080	910
	125			300			540			1,180	750
	150			400			640			1,280	630
	175			500			740			1,380	530
	200			600			840				
BG1502	75	370	BG3310	150	1,100	BG4610	940	390			
	100			200			1,040	315			
	125			300			1,140	260			
	150			400			1,240	220			
	175			500							
BG2001	100	187	BG3320	150	1,500	BG4620	340	1,480			
	150			200			740		1,300		
	200			300			840		1,000		
				400			940		780		
BG2005	100	925	BG3320	500	1,500	BG4620	1,040	630			
	150			600			1,140	520			
	200						1,240	440			

Figure H-5 Guide Rail Length and Allowable Speed

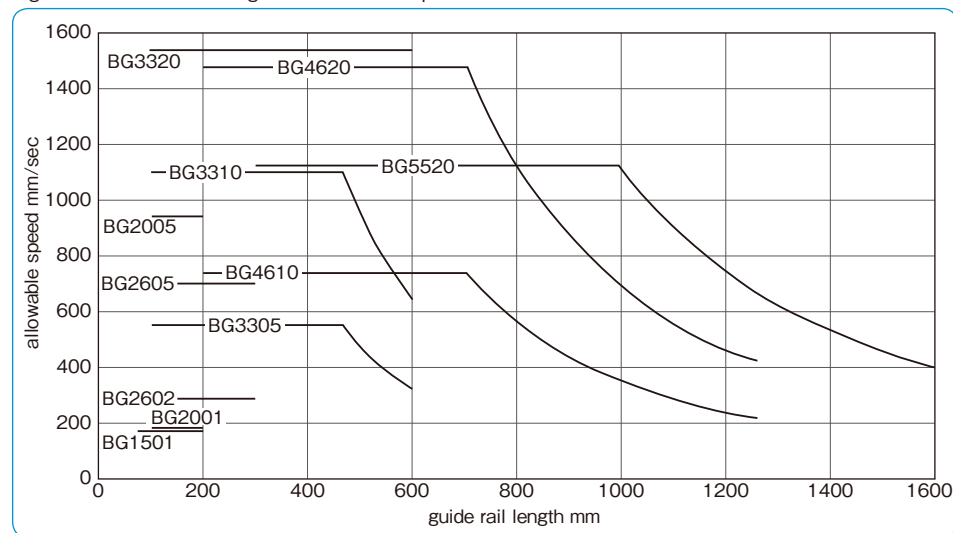

MASS

The mass of the BG type is listed in Table H-3 and slide block mass is listed in Table H-4.

Table H-3 Mass of BG type Actuator

part number	rail length mm	without top cover				with top cover				rail length mm
		long block		short block		long block		short block		
		1 block A	2 blocks B	1 block C	2 blocks D	1 block A	2 blocks B	1 block C	2 blocks D	
BG15	75	0.21	—	—	—	0.24	—	—	—	75
	100	0.25	—	—	—	0.28	—	—	—	100
	125	0.28	0.32	—	—	0.31	0.37	—	—	125
	150	0.32	0.35	—	—	0.35	0.40	—	—	150
	175	0.35	0.39	—	—	0.39	0.44	—	—	175
	200	0.39	0.42	—	—	0.42	0.48	—	—	200
BG20	100	0.45	—	—	—	0.50	—	—	—	100
	150	0.58	0.65	—	—	0.63	0.74	—	—	150
	200	0.71	0.78	—	—	0.77	0.88	—	—	200
BG26	150	0.93	—	—	—	1.07	—	—	—	150
	200	1.14	1.31	—	—	1.30	1.54	—	—	200
	250	1.36	1.53	—	—	1.53	1.78	—	—	250
	300	1.57	1.74	—	—	1.76	2.01	—	—	300
BG33	150	1.6	—	1.5	1.7	1.8	—	1.6	1.9	150
	200	2.0	—	1.8	2.0	2.1	—	2.0	2.2	200
	300	2.6	2.9	2.5	2.7	2.8	3.2	2.6	2.9	300
	400	3.2	3.6	3.1	3.3	3.5	3.9	3.3	3.5	400
	500	3.9	4.2	3.8	3.9	4.2	4.6	4.0	4.2	500
	600	4.6	4.9	4.4	4.6	4.9	5.3	4.7	4.9	600
BG46	340	6.5	7.5	6.0	6.5	7.0	8.0	6.5	7.0	340
	440	8.0	8.5	7.5	8.0	8.5	9.5	8.0	8.5	440
	540	9.0	10.0	8.5	9.5	10.0	11.0	9.5	10.0	540
	640	10.5	11.5	10.0	10.5	11.0	12.5	10.5	11.5	640
	740	12.0	13.0	11.5	12.0	12.5	14.0	12.0	13.0	740
	840	13.0	14.0	13.0	13.5	14.0	15.5	13.5	14.0	840
	940	14.5	15.5	14.0	14.5	15.5	16.5	15.0	15.5	940
	1,040	16.0	17.0	15.5	16.0	17.0	18.0	16.5	17.0	1,040
	1,140	17.5	18.0	17.0	17.5	18.5	19.5	18.0	18.5	1,140
	1,240	18.5	19.5	18.5	19.0	19.5	21.0	19.0	20.0	1,240
BG55	980	20	22	—	—	21	24	—	—	980
	1,080	22	24	—	—	23	26	—	—	1,080
	1,180	23	25	—	—	25	27	—	—	1,180
	1,280	25	27	—	—	27	29	—	—	1,280
	1,380	27	29	—	—	29	31	—	—	1,380

A: 1 long block B: 2 long blocks C: 1 short block D: 2 short blocks

Table H-4 Mass of Block unit / kg

part number	without top cover		with top cover	
	long block	short block	long block	short block
BG15	0.03	—	0.05	—
BG20	0.07	—	0.11	—
BG26	0.17	—	0.24	—
BG33	0.3	0.15	0.4	0.2
BG46	0.9	0.5	1.2	0.7
BG55	1.7	—	2.3	—

Mass stated "with top cover" includes mass of sub table.

**INERTIA**

Inertia of the slide block and ball screw of BG type are shown in Table H-5.

Table H-5 Inertia (reference) unit / kg · m<sup>2</sup>

part number	rail length mm	without top cover				with top cover				rail length mm
		long block		short block		long block		short block		
		1 block A	2 blocks B	1 block C	2 blocks D	1 block A	2 blocks B	1 block C	2 blocks D	
BG1501	75	1.06×10 <sup>-7</sup>	—	—	—	1.07×10 <sup>-7</sup>	—	—	—	75
	100	1.31×10 <sup>-7</sup>	—	—	—	1.31×10 <sup>-7</sup>	—	—	—	100
	125	1.56×10 <sup>-7</sup>	1.56×10 <sup>-7</sup>	—	—	1.56×10 <sup>-7</sup>	1.58×10 <sup>-7</sup>	—	—	125
	150	1.80×10 <sup>-7</sup>	1.81×10 <sup>-7</sup>	—	—	1.81×10 <sup>-7</sup>	1.82×10 <sup>-7</sup>	—	—	150
	175	2.05×10 <sup>-7</sup>	2.06×10 <sup>-7</sup>	—	—	2.06×10 <sup>-7</sup>	2.07×10 <sup>-7</sup>	—	—	175
	200	2.30×10 <sup>-7</sup>	2.31×10 <sup>-7</sup>	—	—	2.31×10 <sup>-7</sup>	2.32×10 <sup>-7</sup>	—	—	200
BG1502	75	1.09×10 <sup>-7</sup>	—	—	—	1.11×10 <sup>-7</sup>	—	—	—	75
	100	1.33×10 <sup>-7</sup>	—	—	—	1.35×10 <sup>-7</sup>	—	—	—	100
	125	1.58×10 <sup>-7</sup>	1.62×10 <sup>-7</sup>	—	—	1.60×10 <sup>-7</sup>	1.66×10 <sup>-7</sup>	—	—	125
	150	1.83×10 <sup>-7</sup>	1.86×10 <sup>-7</sup>	—	—	1.85×10 <sup>-7</sup>	1.90×10 <sup>-7</sup>	—	—	150
	175	2.08×10 <sup>-7</sup>	2.11×10 <sup>-7</sup>	—	—	2.10×10 <sup>-7</sup>	2.15×10 <sup>-7</sup>	—	—	175
	200	2.33×10 <sup>-7</sup>	2.36×10 <sup>-7</sup>	—	—	2.35×10 <sup>-7</sup>	2.40×10 <sup>-7</sup>	—	—	200
BG2001	100	1.34×10 <sup>-7</sup>	—	—	—	1.35×10 <sup>-7</sup>	—	—	—	100
	150	1.83×10 <sup>-7</sup>	1.85×10 <sup>-7</sup>	—	—	1.84×10 <sup>-7</sup>	1.87×10 <sup>-7</sup>	—	—	150
BG2005	200	2.33×10 <sup>-7</sup>	2.35×10 <sup>-7</sup>	—	—	2.34×10 <sup>-7</sup>	2.37×10 <sup>-7</sup>	—	—	200
	100	1.76×10 <sup>-7</sup>	—	—	—	2.00×10 <sup>-7</sup>	—	—	—	100
BG2602	150	2.26×10 <sup>-7</sup>	2.70×10 <sup>-7</sup>	—	—	2.50×10 <sup>-7</sup>	3.18×10 <sup>-7</sup>	—	—	150
	200	2.76×10 <sup>-7</sup>	3.20×10 <sup>-7</sup>	—	—	3.00×10 <sup>-7</sup>	3.68×10 <sup>-7</sup>	—	—	200
	150	6.08×10 <sup>-7</sup>	—	—	—	6.16×10 <sup>-7</sup>	—	—	—	150
BG2605	200	7.65×10 <sup>-7</sup>	7.83×10 <sup>-7</sup>	—	—	7.73×10 <sup>-7</sup>	7.97×10 <sup>-7</sup>	—	—	200
	250	9.22×10 <sup>-7</sup>	9.39×10 <sup>-7</sup>	—	—	9.29×10 <sup>-7</sup>	9.54×10 <sup>-7</sup>	—	—	250
	300	1.08×10 <sup>-6</sup>	1.10×10 <sup>-6</sup>	—	—	1.09×10 <sup>-6</sup>	1.11×10 <sup>-6</sup>	—	—	300
BG3305	150	6.99×10 <sup>-7</sup>	—	—	—	7.44×10 <sup>-7</sup>	—	—	—	150
	200	8.56×10 <sup>-7</sup>	9.63×10 <sup>-7</sup>	—	—	9.01×10 <sup>-7</sup>	1.05×10 <sup>-6</sup>	—	—	200
	250	1.01×10 <sup>-6</sup>	1.12×10 <sup>-6</sup>	—	—	1.06×10 <sup>-6</sup>	1.21×10 <sup>-6</sup>	—	—	250
BG3310	300	1.17×10 <sup>-6</sup>	1.28×10 <sup>-6</sup>	—	—	1.21×10 <sup>-6</sup>	1.37×10 <sup>-6</sup>	—	—	300
	150	1.64×10 <sup>-6</sup>	—	1.56×10 <sup>-6</sup>	1.64×10 <sup>-6</sup>	1.71×10 <sup>-6</sup>	—	1.60×10 <sup>-6</sup>	1.71×10 <sup>-6</sup>	150
	200	2.02×10 <sup>-6</sup>	—	1.94×10 <sup>-6</sup>	2.03×10 <sup>-6</sup>	2.09×10 <sup>-6</sup>	—	1.98×10 <sup>-6</sup>	2.10×10 <sup>-6</sup>	200
	300	2.79×10 <sup>-6</sup>	2.99×10 <sup>-6</sup>	2.71×10 <sup>-6</sup>	2.79×10 <sup>-6</sup>	2.86×10 <sup>-6</sup>	3.13×10 <sup>-6</sup>	2.75×10 <sup>-6</sup>	2.86×10 <sup>-6</sup>	300
	400	3.55×10 <sup>-6</sup>	3.75×10 <sup>-6</sup>	3.48×10 <sup>-6</sup>	3.56×10 <sup>-6</sup>	3.62×10 <sup>-6</sup>	3.89×10 <sup>-6</sup>	3.51×10 <sup>-6</sup>	3.63×10 <sup>-6</sup>	400
	500	4.32×10 <sup>-6</sup>	4.52×10 <sup>-6</sup>	4.24×10 <sup>-6</sup>	4.32×10 <sup>-6</sup>	4.39×10 <sup>-6</sup>	4.66×10 <sup>-6</sup>	4.28×10 <sup>-6</sup>	4.39×10 <sup>-6</sup>	500
BG3320	600	5.08×10 <sup>-6</sup>	5.28×10 <sup>-6</sup>	5.01×10 <sup>-6</sup>	5.09×10 <sup>-6</sup>	5.15×10 <sup>-6</sup>	5.42×10 <sup>-6</sup>	5.04×10 <sup>-6</sup>	5.16×10 <sup>-6</sup>	600
	150	2.19×10 <sup>-6</sup>	—	1.88×10 <sup>-6</sup>	2.21×10 <sup>-6</sup>	2.47×10 <sup>-6</sup>	—	2.02×10 <sup>-6</sup>	2.49×10 <sup>-6</sup>	150
	200	2.57×10 <sup>-6</sup>	—	2.27×10 <sup>-6</sup>	2.59×10 <sup>-6</sup>	2.85×10 <sup>-6</sup>	—	2.40×10 <sup>-6</sup>	2.87×10 <sup>-6</sup>	200
	300	3.34×10 <sup>-6</sup>	4.14×10 <sup>-6</sup>	3.03×10 <sup>-6</sup>	3.36×10 <sup>-6</sup>	3.61×10 <sup>-6</sup>	4.69×10 <sup>-6</sup>	3.17×10 <sup>-6</sup>	3.64×10 <sup>-6</sup>	300
	400	4.10×10 <sup>-6</sup>	4.90×10 <sup>-6</sup>	3.80×10 <sup>-6</sup>	4.12×10 <sup>-6</sup>	4.38×10 <sup>-6</sup>	5.46×10 <sup>-6</sup>	3.94×10 <sup>-6</sup>	4.40×10 <sup>-6</sup>	400
	500	4.87×10 <sup>-6</sup>	5.67×10 <sup>-6</sup>	4.56×10 <sup>-6</sup>	4.89×10 <sup>-6</sup>	5.15×10 <sup>-6</sup>	6.22×10 <sup>-6</sup>	4.70×10 <sup>-6</sup>	5.17×10 <sup>-6</sup>	500
BG4610	600	5.63×10 <sup>-6</sup>	6.43×10 <sup>-6</sup>	5.33×10 <sup>-6</sup>	5.65×10 <sup>-6</sup>	5.91×10 <sup>-6</sup>	6.99×10 <sup>-6</sup>	5.47×10 <sup>-6</sup>	5.93×10 <sup>-6</sup>	600
	150	5.94×10 <sup>-6</sup>	—	—	—	7.06×10 <sup>-6</sup>	—	—	—	150
	200	6.74×10 <sup>-6</sup>	—	—	—	7.85×10 <sup>-6</sup>	—	—	—	200
	300	8.33×10 <sup>-6</sup>	1.15×10 <sup>-5</sup>	—	—	9.44×10 <sup>-6</sup>	1.38×10 <sup>-5</sup>	—	—	300
	400	9.91×10 <sup>-6</sup>	1.31×10 <sup>-5</sup>	—	—	1.10×10 <sup>-5</sup>	1.53×10 <sup>-5</sup>	—	—	400
	500	1.15×10 <sup>-5</sup>	1.47×10 <sup>-5</sup>	—	—	1.26×10 <sup>-5</sup>	1.69×10 <sup>-5</sup>	—	—	500
BG4610	600	1.31×10 <sup>-5</sup>	1.63×10 <sup>-5</sup>	—	—	1.42×10 <sup>-5</sup>	1.85×10 <sup>-5</sup>	—	—	600
	340	1.79×10 <sup>-5</sup>	2.02×10 <sup>-5</sup>	1.69×10 <sup>-5</sup>	1.82×10 <sup>-5</sup>	1.87×10 <sup>-5</sup>	2.17×10 <sup>-5</sup>	1.74×10 <sup>-5</sup>	1.92×10 <sup>-5</sup>	340
	440	2.18×10 <sup>-5</sup>	2.41×10 <sup>-5</sup>	2.08×10 <sup>-5</sup>	2.20×10 <sup>-5</sup>	2.25×10 <sup>-5</sup>	2.56×10 <sup>-5</sup>	2.13×10 <sup>-5</sup>	2.31×10 <sup>-5</sup>	440
	540	2.57×10 <sup>-5</sup>	2.79×10 <sup>-5</sup>	2.46×10 <sup>-5</sup>	2.59×10 <sup>-5</sup>	2.64×10 <sup>-5</sup>	2.95×10 <sup>-5</sup>	2.52×10 <sup>-5</sup>	2.69×10 <sup>-5</sup>	540
	640	2.95×10 <sup>-5</sup>	3.18×10 <sup>-5</sup>	2.85×10 <sup>-5</sup>	2.98×10 <sup>-5</sup>	3.03×10 <sup>-5</sup>	3.33×10 <sup>-5</sup>	2.90×10 <sup>-5</sup>	3.08×10 <sup>-5</sup>	640
	740	3.34×10 <sup>-5</sup>	3.57×10 <sup>-5</sup>	3.24×10 <sup>-5</sup>	3.37×10 <sup>-5</sup>	3.42×10 <sup>-5</sup>	3.72×10 <sup>-5</sup>	3.29×10 <sup>-5</sup>	3.47×10 <sup>-5</sup>	740
BG4610	840	3.73×10 <sup>-5</sup>	3.96×10 <sup>-5</sup>	3.63×10 <sup>-5</sup>	3.75×10 <sup>-5</sup>	3.80×10 <sup>-5</sup>	4.11×10 <sup>-5</sup>	3.67×10 <sup>-5</sup>	3.83×10 <sup>-5</sup>	840
	940	4.12×10 <sup>-5</sup>	4.35×10 <sup>-5</sup>	4.02×10 <sup>-5</sup>	4.14×10 <sup>-5</sup>	4.19×10 <sup>-5</sup>	4.50×10 <sup>-5</sup>	4.06×10 <sup>-5</sup>	4.22×10 <sup>-5</sup>	940
	1,040	4.50×10 <sup>-5</sup>	4.74×10 <sup>-5</sup>	4.41×10 <sup>-5</sup>	4.53×10 <sup>-5</sup>	4.58×10 <sup>-5</sup>	4.88×10 <sup>-5</sup>	4.44×10 <sup>-5</sup>	4.61×10 <sup>-5</sup>	1,040
	1,140	4.89×10 <sup>-5</sup>	5.12×10 <sup>-5</sup>	4.79×10 <sup>-5</sup>	4.92×10 <sup>-5</sup>	4.97×10 <sup>-5</sup>	5.27×10 <sup>-5</sup>	4.83×10 <sup>-5</sup>	4.99×10 <sup>-5</sup>	1,140
	1,240	5.28×10 <sup>-5</sup>	5.51×10 <sup>-5</sup>	5.18×10 <sup>-5</sup>	5.30×10 <sup>-5</sup>	5.35×10 <sup>-5</sup>	5.66×10 <sup>-5</sup>	5.22×10 <sup>-5</sup>	5.38×10 <sup>-5</sup>	1,240

Table H-5 Inertia (reference) unit / kg · m<sup>2</sup>

part number	rail length mm	without top cover				with top cover				rail length mm
		long block		short block		long block		short block		
		1 block A	2 blocks B	1 block C	2 blocks D	1 block A	2 blocks B	1 block C	2 blocks D	
BG4620	340	2.47×10 <sup>-5</sup>	3.39×10 <sup>-5</sup>	2.07×10 <sup>-5</sup>	2.58×10 <sup>-5</sup>	2.78×10 <sup>-5</sup>	3.99×10 <sup>-5</sup>	2.27×10 <sup>-5</sup>	2.98×10 <sup>-5</sup>	340
	440	2.86×10 <sup>-5</sup>	3.77×10 <sup>-5</sup>	2.46×10 <sup>-5</sup>	2.96×10 <sup>-5</sup>	3.17×10 <sup>-5</sup>	4.38×10 <sup>-5</sup>	2.66×10 <sup>-5</sup>	3.37×10 <sup>-5</sup>	440
	540	3.25×10 <sup>-5</sup>	4.16×10 <sup>-5</sup>	2.84×10 <sup>-5</sup>	3.35×10 <sup>-5</sup>	3.55×10 <sup>-5</sup>	4.77×10 <sup>-5</sup>	3.05×10 <sup>-5</sup>	3.76×10 <sup>-5</sup>	540
	640	3.63×10 <sup>-5</sup>	4.55×10 <sup>-5</sup>	3.23×10 <sup>-5</sup>	3.74×10 <sup>-5</sup>	3.94×10 <sup>-5</sup>	5.16×10 <sup>-5</sup>	3.44×10 <sup>-5</sup>	4.14×10 <sup>-5</sup>	640
	740	4.03×10 <sup>-5</sup>	4.94×10 <sup>-5</sup>	3.62×10 <sup>-5</sup>	4.13×10 <sup>-5</sup>	4.33×10 <sup>-5</sup>	5.55×10 <sup>-5</sup>	3.82×10 <sup>-5</sup>	4.53×10 <sup>-5</sup>	740
	840	4.41×10 <sup>-5</sup>	5.34×10 <sup>-5</sup>	4.02×10 <sup>-5</sup>	4.51×10 <sup>-5</sup>	4.71×10 <sup>-5</sup>	5.93×10 <sup>-5</sup>	4.17×10 <sup>-5</sup>	4.82×10 <sup>-5</sup>	840
	940	4.80×10 <sup>-5</sup>	5.72×10 <sup>-5</sup>	4.41×10 <sup>-5</sup>	4.90×10 <sup>-5</sup>	5.09×10 <sup>-5</sup>	6.32×10 <sup>-5</sup>	4.56×10 <sup>-5</sup>	5.21×10 <sup>-5</sup>	940
	1,040	5.19×10 <sup>-5</sup>	6.11×10 <sup>-5</sup>	4.80×10 <sup>-5</sup>	5.29×10 <sup>-5</sup>	5.48×10 <sup>-5</sup>	6.71×10 <sup>-5</sup>	4.95×10 <sup>-5</sup>	5.59×10 <sup>-5</sup>	1,040
	1,140	5.57×10 <sup>-5</sup>	6.50×10 <sup>-5</sup>	5.18×10 <sup>-5</sup>	5.68×10 <sup>-5</sup>	5.87×10 <sup>-5</sup>	7.09×10 <sup>-5</sup>	5.34×10 <sup>-5</sup>	5.98×10 <sup>-5</sup>	1,140
	1,240	5.96×10 <sup>-5</sup>	6.89×10 <sup>-5</sup>	5.57×10 <sup>-5</sup>	6.06×10 <sup>-5</sup>	6.26×10 <sup>-5</sup>	7.48×10 <sup>-5</sup>	5.72×10 <sup>-5</sup>	6.37×10 <sup>-5</sup>	1,240
BG5520	980	1.46×10 <sup>-4</sup>	1.64×10 <sup>-4</sup>	—	—	1.52×10 <sup>-4</sup>	1.76×10 <sup>-4</sup>	—	—	980
	1,080	1.59×10 <sup>-4</sup>	1.76×10 <sup>-4</sup>	—	—	1.65×10 <sup>-4</sup>	1.88×10 <sup>-4</sup>	—	—	1,080
	1,180	1.71×10 <sup>-4</sup>	1.88×10 <sup>-4</sup>	—	—	1.77×10 <sup>-4</sup>	2.00×10 <sup>-4</sup>	—	—	1,180
	1,280	1.83×10 <sup>-4</sup>	2.00×10 <sup>-4</sup>	—	—	1.89×10 <sup>-4</sup>	2.12×10 <sup>-4</sup>	—	—	1,280
	1,380	1.95×10 <sup>-4</sup>	2.13×10 <sup>-4</sup>	—	—	2.01×10 <sup>-4</sup>	2.25×10 <sup>-4</sup>	—	—	1,380

**RIGIDITY**

By utilizing four-circuit and four-point contact structure, the BG type provides extremely high rigidity. Figure H-6 shows displacement of each size of long block against radial load. Table H-6 shows the geometrical moment of inertia of guide rails.

Figure H-6 Block Displacement against Radial Load

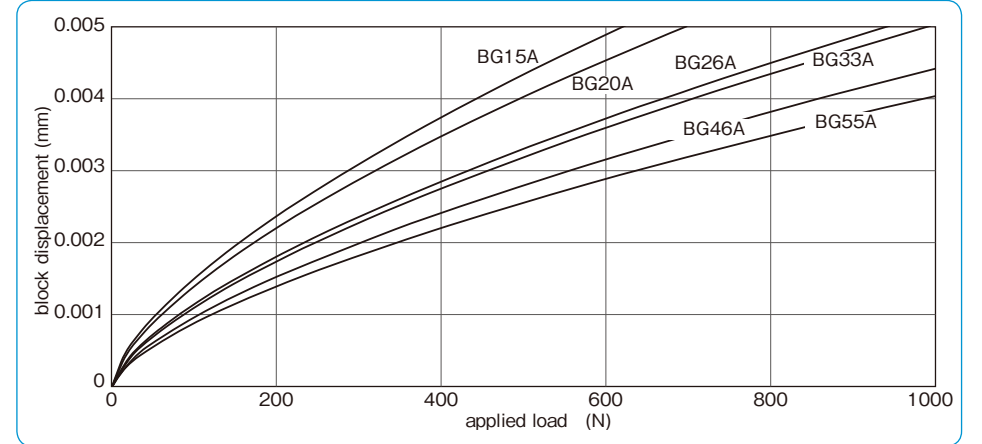
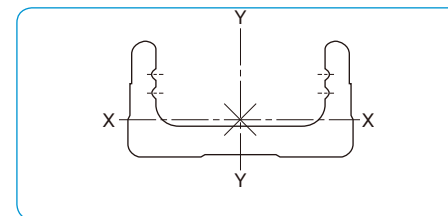

Table H-6 Geometrical Moment of Inertia of Guide Rail

part number	geometrical moment of inertia (mm <sup>4</sup> )	mass W (kg/100mm)
<b>BG15</b>	1.22 × 10 <sup>3</sup>	0.12
<b>BG20</b>	6.50 × 10 <sup>3</sup>	0.25
<b>BG26</b>	1.69 × 10 <sup>4</sup>	0.38
<b>BG33</b>	5.11 × 10 <sup>4</sup>	0.60
<b>BG46</b>	2.42 × 10 <sup>5</sup>	1.24
<b>BG55</b>	2.29 × 10 <sup>5</sup>	1.50



ACCURACY

Table H-7 shows accuracy of BG type.

Table H-7 Accuracy

part number	rail length mm	positioning repeatability		positioning accuracy		running parallelism B		backlash		※starting torque			
		high $\mu\text{m}$	precision $\mu\text{m}$	high $\mu\text{m}$	precision $\mu\text{m}$	high $\mu\text{m}$	precision $\mu\text{m}$	high $\mu\text{m}$	precision $\mu\text{m}$	high $\mu\text{m}$	precision $\mu\text{m}$		
BG15	75	$\pm 3$	$\pm 1$	40	20	20	10	5	2	0.01	0.012		
	100												
	125												
	150												
	175												
BG20	200	$\pm 3$	$\pm 1$	50	20	25	10	5	2	0.01	0.012		
	150												
	100												
BG26	300	$\pm 3$	$\pm 1$	50	20	25	10	5	2	0.015	0.04		
	250												
	200												
	150												
BG33	600	$\pm 3$ ( $\pm 5$ )	$\pm 1$ ( $\pm 3$ )	30	15	25	10	5	2	0.07	0.15		
	500												
	400												
	300												
	200												
BG46	1,240	$\pm 3$ ( $\pm 5$ )	$\pm 1$ ( $\pm 3$ )	35	20	35	15	5	2	0.10	0.15		
	940												
	840												
	740			40	25	50	-					-	-
	640												
	540												
	440												
	340												
	BG55			1,380	$\pm 3$	$\pm 1$	80						
1,280													
1,180													
1,080													
980													
				100	-								

Above values are measured by using our selected motors.  
 ※ Above specifications are based on using NB standard grease. Other grease may cause deviations.  
 The values in the parentheses are positioning repeatability when used with return pulley unit.

Positioning Repeatability

After setting an arbitrary position, from one end, move the drive block to this position and measure the stop position. Repeat the positioning and measurement process 7 times with respect to the setting position at the midpoint and near both ends of travel. Take the maximum difference and divide it by 2, then indicate it with a positive and negative sign as the test result.

Positioning Repeatability

$$= \pm \frac{1}{2} ((\text{maximum value of } \ell_n) - (\text{minimum value of } \ell_n))$$

Figure H-7 Positioning Repeatability

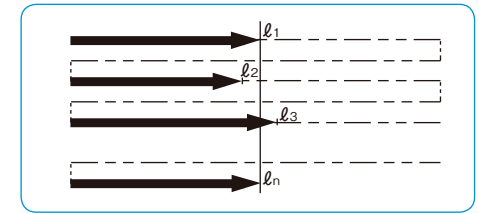

Positioning Accuracy

Positioning is performed in one direction and the resulting position is set as the datum point. Take the difference between the actual travel distance and the commanded travel distance from the datum point. Continuing in the same direction (without returning to the start point) repeat this process randomly several times until nearing to the stroke limit. Express the accuracy by the absolute maximum difference.

$$\text{Positioning Accuracy} = (\Delta \ell_n)_{\text{max}}$$

Figure H-8 Positioning Accuracy

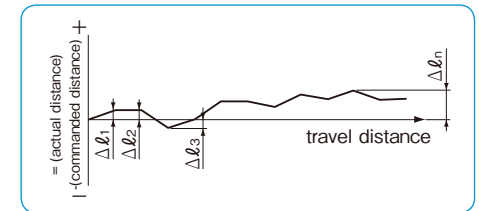

Running Parallelism B

After fixing the guide rail onto the surface plate, placing the dial test indicator on the center of the slide block and connecting the indicator probe onto the mounting surface, run the block over the entire travel distance. Take the maximum deviation in readings as the test result.

Figure H-9 Running Parallelism

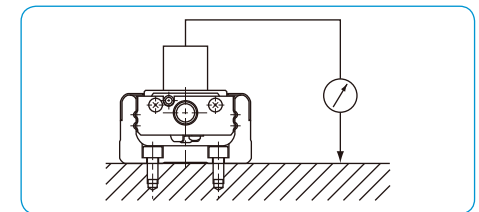

Backlash

Using the feed screw to move the slide block a little, take the dial test indicator reading and make it the datum point. While in this position, thrust the block by a certain force in the same direction without using the feed screw. Release the thrust and read the return, then take the difference from the datum point. Repeat the same process at the midpoint and near both ends of travel. Take the maximum difference as the test result.

Figure H-10 Backlash

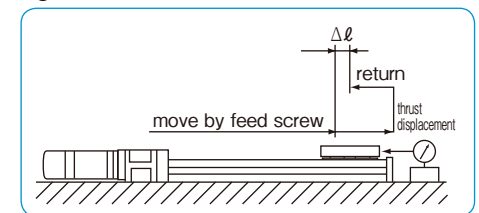

$$\text{Backlash} = \Delta \ell$$

RATED LIFE

To obtain the rated life of the BG type, calculate the rated life of the guide portion, ball screw portion and support bearing portion. Use the minimum value as the rated life of the BG type.

A. Life of Guide Portion

Use the following equation for calculating the rated life of guide portion.

$$L_G = \left( \frac{f_c \cdot C}{f_w \cdot P_T} \right)^3 \cdot 50 \quad \dots\dots\dots (1)$$

$L_G$ : rated life (km)  $f_c$ : contact coefficient (refer to Table H-8)  
 $f_w$ : applied load coefficient (refer to Table H-9)  
 $C$ : basic dynamic load rating (N)  
 $P_T$ : calculated load applied to one block (N)

A.1. Calculation of  $P_T$

Before calculating the rated life using the equation (1), the calculated load applied to one block ( $P_T$ ) needs to be obtained in consideration of the moment load, etc. that will be actually applied. For rapidly-accelerating or short stroke motion,  $P_T$  needs to be calculated with acceleration taken into consideration. The calculation of this acceleration will be carried out for the mass applied to BG. Obtain the calculated load during uniform motion, acceleration, and deceleration, and use the average value of the three as  $P_T$ .

For the calculation of  $P_T$ , select an appropriate equation depending on the installation conditions of the guide.

It is also possible to calculate  $P_T$  without including the effect of acceleration by using the equation " $P_T = P_{TC}$  (see the equations (2), (5), and (8)). In this case, however, the obtained value is a rough approximation, so a selection with sufficient margin is recommended.

Table H-8 Contact Coefficient ( $f_c$ )

number of blocks in close contact on one axis	contact coefficient ( $f_c$ )
1	1.0
2	0.81

Table H-9 Applied Load Coefficient ( $f_w$ )

operating conditions		applied load coefficient ( $f_w$ )
vibration, impact	velocity	
none	15m/min or less	1.0 ~ 1.5
low	60m/min or less	1.5 ~ 2.0
high	60m/min or more	2.0 ~ 3.5

Table H-10 Moment Equivalent Coefficient

	$E_p$ (E2p)	$E_y$ (E2y)	$E_r$ (E2r)
BG15 * * A	$2.82 \times 10^{-1}$	$2.37 \times 10^{-1}$	$9.35 \times 10^{-2}$
BG15 * * B	$5.16 \times 10^{-2}$	$4.33 \times 10^{-2}$	$4.67 \times 10^{-2}$
BG20 * * A	$2.25 \times 10^{-1}$	$1.89 \times 10^{-1}$	$7.84 \times 10^{-2}$
BG20 * * B	$3.98 \times 10^{-2}$	$3.34 \times 10^{-2}$	$3.92 \times 10^{-2}$
BG26 * * A	$1.51 \times 10^{-1}$	$1.27 \times 10^{-1}$	$5.88 \times 10^{-2}$
BG26 * * B	$2.72 \times 10^{-2}$	$2.28 \times 10^{-2}$	$2.94 \times 10^{-2}$
BG33 * * A	$1.26 \times 10^{-1}$	$1.06 \times 10^{-1}$	$4.55 \times 10^{-2}$
BG33 * * B	$2.20 \times 10^{-2}$	$1.84 \times 10^{-2}$	$2.27 \times 10^{-2}$
BG33 * * C	$2.31 \times 10^{-1}$	$1.94 \times 10^{-1}$	$4.55 \times 10^{-2}$
BG33 * * D	$3.09 \times 10^{-2}$	$2.59 \times 10^{-2}$	$2.27 \times 10^{-2}$
BG46 * * A	$8.39 \times 10^{-2}$	$7.04 \times 10^{-2}$	$3.17 \times 10^{-2}$
BG46 * * B	$1.56 \times 10^{-2}$	$1.31 \times 10^{-2}$	$1.59 \times 10^{-2}$
BG46 * * C	$1.39 \times 10^{-1}$	$1.17 \times 10^{-1}$	$3.17 \times 10^{-2}$
BG46 * * D	$2.15 \times 10^{-2}$	$1.81 \times 10^{-2}$	$1.59 \times 10^{-2}$
BG55 * * A	$6.80 \times 10^{-2}$	$5.71 \times 10^{-2}$	$2.74 \times 10^{-2}$
BG55 * * B	$1.35 \times 10^{-2}$	$1.14 \times 10^{-2}$	$1.37 \times 10^{-2}$

\*The E2 coefficient is for two blocks being used in close contact.

A.1.a.  $P_T$  for Horizontal Move (Horizontal Mounting)

i) during uniform motion ( $P_{TC}$ )

$$P_{TC} = \frac{1}{n} \cdot W + E_p \cdot M_{pL} + E_y \cdot M_{yL} + E_r \cdot M_{rL} \quad \dots\dots\dots (2)$$

ii) during acceleration ( $P_{Ta}$ )

$$P_{Ta} = \frac{1}{n} \cdot W + E_p(M_{pL} + m \cdot \alpha_a \cdot Z) + E_y(M_{yL} + m \cdot \alpha_a \cdot X) + E_r \cdot M_{rL} \quad \dots\dots\dots (3)$$

Note that the values of ( $M_{pL} + m \cdot \alpha_a \cdot Z$ ) and ( $M_{yL} + m \cdot \alpha_a \cdot X$ ) will be treated as 0 (zero) when the calculated value is negative.

iii) during deceleration ( $P_{Td}$ )

$$P_{Td} = \frac{1}{n} \cdot W + E_p(M_{pL} + m \cdot \alpha_d \cdot Z) + E_y(M_{yL} + m \cdot \alpha_d \cdot X) + E_r \cdot M_{rL} \quad \dots\dots\dots (4)$$

Note that the values of ( $M_{pL} + m \cdot \alpha_d \cdot Z$ ) and ( $M_{yL} + m \cdot \alpha_d \cdot X$ ) will be treated as 0 (zero) when the calculated value is negative.

$P_{TC}$ : calculated load applied to a block during uniform motion (N)  $P_{Ta}$ : calculated load applied to a block during accelerating (N)  
 $P_{Td}$ : calculated load applied to a block during decelerating (N)  $n$ : number of blocks of BG  $W$ : applied load (N)  $m$ : carrying mass (kg)  
 $\alpha_a$ : acceleration during accelerating (m/sec<sup>2</sup>)  $\alpha_d$ : acceleration during decelerating (m/sec<sup>2</sup>) (the negative value)  
 $X$ : distance between the center of BG and the center of the carrying mass (mm)  
 $Y$ : distance between the center of BG and the center of the carrying mass (mm)  
 $Z$ : distance between the center of BG ball screw and the center of the carrying mass (mm)  
 $E_p$ : moment equivalent coefficient in the pitching direction (refer to Table H-10)  
 $E_y$ : moment equivalent coefficient in the yawing direction (refer to Table H-10)  
 $E_r$ : moment equivalent coefficient in the rolling direction (refer to Table H-10)  
 $M_{pL}$ : applied moment in the pitching direction (N · mm)  $M_{pL} = W \cdot Y$   
 $M_{yL}$ : applied moment in the yawing direction (N · mm)  $M_{yL} = 0$   
 $M_{rL}$ : applied moment in the rolling direction (N · mm)  $M_{rL} = W \cdot X$  ※Refer to Fig.H-4 for the direction of moment.

Figure H-11

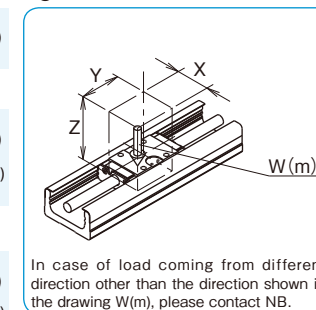

In case of load coming from different direction other than the direction shown in the drawing W(m), please contact NB.

A.1.b.  $P_T$  for Horizontal Move (Wall Mounting)

i) during uniform motion ( $P_{TC}$ )

$$P_{TC} = \frac{1}{1.19 \cdot n} \cdot W + E_p \cdot M_{pL} + E_y \cdot M_{yL} + E_r \cdot M_{rL} \quad \dots\dots\dots (5)$$

ii) during acceleration ( $P_{Ta}$ )

$$P_{Ta} = \frac{1}{1.19 \cdot n} \cdot W + E_p(M_{pL} + m \cdot \alpha_a \cdot Z) + E_y(M_{yL} + m \cdot \alpha_a \cdot X) + E_r \cdot M_{rL} \quad \dots\dots\dots (6)$$

Note that the values of ( $M_{pL} + m \cdot \alpha_a \cdot Z$ ) and ( $M_{yL} + m \cdot \alpha_a \cdot X$ ) will be treated as 0 (zero) when the calculated value is negative.

iii) during deceleration ( $P_{Td}$ )

$$P_{Td} = \frac{1}{1.19 \cdot n} \cdot W + E_p(M_{pL} + m \cdot \alpha_d \cdot Z) + E_y(M_{yL} + m \cdot \alpha_d \cdot X) + E_r \cdot M_{rL} \quad \dots\dots\dots (7)$$

Note that the values of ( $M_{pL} + m \cdot \alpha_d \cdot Z$ ) and ( $M_{yL} + m \cdot \alpha_d \cdot X$ ) will be treated as 0 (zero) when the calculated value is negative.

$P_{TC}$ : calculated load applied to a block during uniform motion (N)  $P_{Ta}$ : calculated load applied to a block during accelerating (N)  
 $P_{Td}$ : calculated load applied to a block during decelerating (N)  $n$ : number of blocks of BG  $W$ : applied load (N)  $m$ : carrying mass (kg)  
 $\alpha_a$ : acceleration during accelerating (m/sec<sup>2</sup>)  $\alpha_d$ : acceleration during decelerating (m/sec<sup>2</sup>) (the negative value)  
 $X$ : distance between the center of BG and the center of the carrying mass (mm)  
 $Y$ : distance between the center of BG and the center of the carrying mass (mm)  
 $Z$ : distance between the center of BG ball screw and the center of the carrying mass (mm)  
 $E_p$ : moment equivalent coefficient in the pitching direction (refer to Table H-10)  $E_y$ : moment equivalent coefficient in the yawing direction (refer to Table H-10)  $E_r$ : moment equivalent coefficient in the rolling direction (refer to Table H-10)  
 $M_{pL}$ : applied moment in the pitching direction (N · mm)  $M_{pL} = 0$   
 $M_{yL}$ : applied moment in the yawing direction (N · mm)  $M_{yL} = W \cdot Y$   
 $M_{rL}$ : applied moment in the rolling direction (N · mm)  $M_{rL} = W \cdot Z$  ※Refer to Fig. H-4 for the direction of moment.

Figure H-12

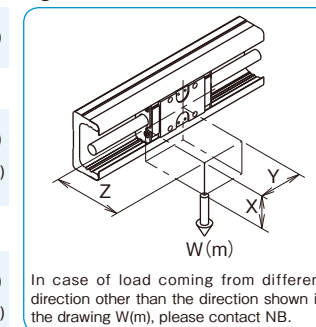

In case of load coming from different direction other than the direction shown in the drawing W(m), please contact NB.

**A.1.c. P<sub>T</sub> for Vertical Move**

i) during uniform motion (P<sub>TC</sub>)

$$P_{TC} = E_p \cdot M_{pL} + E_y \cdot M_{yL} + E_r \cdot M_{rL} \dots\dots\dots (8)$$

ii) during acceleration (P<sub>TA</sub>)

$$P_{TA} = E_p(M_{pL} + m \cdot a_a \cdot Z) + E_y(M_{yL} + m \cdot a_a \cdot X) + E_r \cdot M_{rL} \dots\dots\dots (9)$$

Note that the values of (M<sub>pL</sub>+m·a<sub>a</sub>·Z) and (M<sub>yL</sub>+m·a<sub>a</sub>·X) will be treated as 0 (zero) when the calculated value is negative.

iii) during deceleration (P<sub>TD</sub>)

$$P_{TD} = E_p(M_{pL} + m \cdot a_d \cdot Z) + E_y(M_{yL} + m \cdot a_d \cdot X) + E_r \cdot M_{rL} \dots\dots\dots (10)$$

Note that the values of (M<sub>pL</sub>+m·a<sub>d</sub>·Z) and (M<sub>yL</sub>+m·a<sub>d</sub>·X) will be treated as 0 (zero) when the calculated value is negative.

P<sub>TC</sub>: calculated load applied to a block during uniform motion(N) P<sub>TA</sub>: calculated load applied to a block during accelerating(N)  
 P<sub>TD</sub>: calculated load applied to a block during decelerating(N) n: number of blocks of BG W: applied load(N) m: carrying mass(kg)  
 a<sub>a</sub>: acceleration during accelerating(m/sec<sup>2</sup>) a<sub>d</sub>: acceleration during decelerating(m/sec<sup>2</sup>) (the negative value)  
 X: distance between the center of BG and the center of the carrying mass(mm)  
 Y: distance between the center of BG and the center of the carrying mass(mm)  
 Z: distance between the center of BG ball screw and the center of the carrying mass(mm)  
 E<sub>p</sub>: moment equivalent coefficient in the pitching direction (refer to Table H-10)  
 E<sub>y</sub>: moment equivalent coefficient in the yawing direction (refer to Table H-10)  
 E<sub>r</sub>: moment equivalent coefficient in the rolling direction (refer to Table H-10)  
 M<sub>pL</sub>: applied moment in the pitching direction (N·mm) M<sub>rL</sub>=W·Z M<sub>yL</sub>: loaded moment in the yawing direction (N·mm) M<sub>yL</sub>=W·X  
 M<sub>rL</sub>: applied moment in the rolling direction (N·mm) M<sub>rL</sub>=0 ※Refer to Fig. H-4 for the direction of moment.

Figure H-13

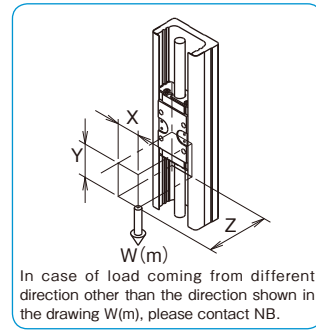

**A.1.d.**

Obtain the calculated load applied to a block (P<sub>T</sub>) by calculating the average load of each motion using an appropriate equation among those shown above according to the application.

$$P_T = \sqrt[3]{\frac{1}{S_1+S_2+S_3} (P_{TA}^3 \cdot S_1 + P_{TC}^3 \cdot S_2 + P_{TD}^3 \cdot S_3)} \dots\dots\dots (11)$$

P<sub>T</sub>: calculated load applied to one block (N)  
 S<sub>1</sub>: travel distance during acceleration (mm) (refer to Figure H-14)  
 S<sub>2</sub>: travel distance during uniform motion (mm) (refer to Figure H-14)  
 S<sub>3</sub>: travel distance during deceleration (mm) (refer to Figure H-14)  
 P<sub>TA</sub>: calculated load applied to one block during accelerating (N): equation (3), (6), and (9)  
 P<sub>TC</sub>: calculated load applied to one block during uniform motion (N): equation (2), (5), and (8)  
 P<sub>TD</sub>: calculated load applied to one block during decelerating (N): equation (4), (7), and (10)

Figure H-14

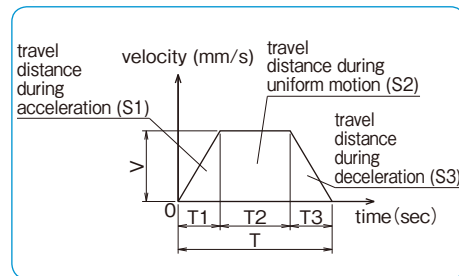

**B. Life of Ball Screw and Support Bearing**

The life of ball screw and support bearing can be calculated using a common equation, as shown below. Compare the dynamic load rating of the ball screw and the support bearing and apply smaller value for calculation.

$$L_a = \left( \frac{1}{f_w} \cdot \frac{C_a \text{ or } C_b}{P_a} \right)^3 \cdot \ell \dots\dots\dots (12)$$

L<sub>a</sub>: rated life (km) f<sub>w</sub>: applied load coefficient (refer to Table H-9)  
 C<sub>a</sub>: basic dynamic load rating of the ball screw (N)  
 C<sub>b</sub>: basic dynamic load rating of the support bearing (N)  
 P<sub>a</sub>: axial load (N) ℓ: ball screw lead (mm)

**B.1. Calculation of Pa**

Before calculating the life using the equation (12), calculate P<sub>a</sub> with acceleration taken into consideration. Calculate the load in each axial direction during uniform motion, acceleration, and deceleration and the obtained value is used as P<sub>a</sub>.

**B.1.a. For Horizontal Move**

i) during uniform motion (P<sub>ac</sub>)

$$P_{ac} = \mu \cdot W + F + f_b \cdot n \dots\dots\dots (13)$$

ii) during acceleration (P<sub>aa</sub>)

$$P_{aa} = \mu \cdot W + F + f_b \cdot n + (m + m_b \cdot n) a_a \dots\dots\dots (14)$$

iii) during deceleration (P<sub>ad</sub>)

$$P_{ad} = \mu \cdot W + F + f_b \cdot n + (m + m_b \cdot n) a_d \dots\dots\dots (15)$$

**B.1.b. For Vertical Move**

i) during uniform motion (P<sub>ac</sub>)

$$P_{ac} = (m + m_b \cdot n)g + F + f_b \cdot n \dots\dots\dots (16)$$

ii) during acceleration (P<sub>aa</sub>)

$$P_{aa} = (m + m_b \cdot n) \cdot (g + a_a) + F + f_b \cdot n_a \dots\dots\dots (17)$$

iii) during deceleration (P<sub>ad</sub>)

$$P_{ad} = (m + m_b \cdot n) \cdot (g + a_d) + F + f_b \cdot n_d \dots\dots\dots (18)$$

**B.1.c.**

Obtain the average axial load (P<sub>a</sub>) using an appropriate formula among those shown above depending on the application.

$$P_a = \sqrt[3]{\frac{1}{S_1+S_2+S_3} (P_{aa}^3 \cdot S_1 + P_{ac}^3 \cdot S_2 + P_{ad}^3 \cdot S_3)} \dots\dots\dots (19)$$

P<sub>a</sub>: average axial load (N)  
 S<sub>1</sub>: travel distance during acceleration (mm) (refer to Table H-14)  
 S<sub>2</sub>: travel distance during uniform motion (mm) (refer to Table H-14)  
 S<sub>3</sub>: travel distance during deceleration (mm) (refer to Table H-14)  
 P<sub>aa</sub>: axial load during accelerating (N): formulas (14) and (17)  
 P<sub>ac</sub>: axial load during uniform motion (N): formulas (13) and (16)  
 P<sub>ad</sub>: axial load during decelerating (N): formulas (15) and (18)

Table H-11 Sliding Resistance (f<sub>b</sub>) of a Single Block (Seal Resistance) unit: N

	high grade (H)	precision grade (P)
BG15	0.8	1.8
BG20	2.3	4.9
BG26	5.4	9.8
BG33	4.4	10.2
BG46	7.4	13.3
BG55	9	16

P<sub>ac</sub>: axial load rating during uniform motion (N)  
 P<sub>aa</sub>: axial load rating during accelerating (N)  
 P<sub>ad</sub>: axial load rating during decelerating (N)  
 μ: friction coefficient W: load applied to a block (N)  
 F: external force (load) applied to the axial direction (N)  
 f<sub>b</sub>: sliding resistance of a single block (N) (refer to Table H-11)  
 n: number of blocks of BG m: carrying mass (kg)  
 m<sub>b</sub>: mass of a block of BG (kg) (refer to Table H-4)  
 a<sub>a</sub>: acceleration during accelerating (m/s<sup>2</sup>)  
 a<sub>d</sub>: acceleration during decelerating (m/s<sup>2</sup>)  
 g: acceleration of gravity

LUBRICATION

- BG type contains a lithium soap based grease. (Multemp PS No.2, KYODO YUSHI) Apply similar type of grease for the lubrication as required depending on the operating conditions.
- Use the grease fitting to lubricate the slide block. For ball screw portion apply grease directly to the surface of screw shaft.
- ※ BG15 slide block has  $\phi 2\text{mm}$  oil holes instead of grease fitting.
- Unless otherwise instructed, a grease fitting is located as shown in Figure H-15.
- The grease can be changed to a high function type by adding a special grease option at the end of the part number. Please refer to Table H-12 for the grease type. Also refer to page Eng-39 for further details.

Table H-12 Applicable Grease

grease option	features	product name
none (standard)	—	Multemp PS No.2 (KYODO YUSHI)
GK	urea-type low dust generation grease	K Grease
GU	urea-type low dust generation grease; low sliding resistance	KGU Grease
GL	lithium-type low dust generation grease	KGL Grease
GF	urea-type anti-fretting grease	KGF Grease

Figure H-15 Location of Grease Fitting

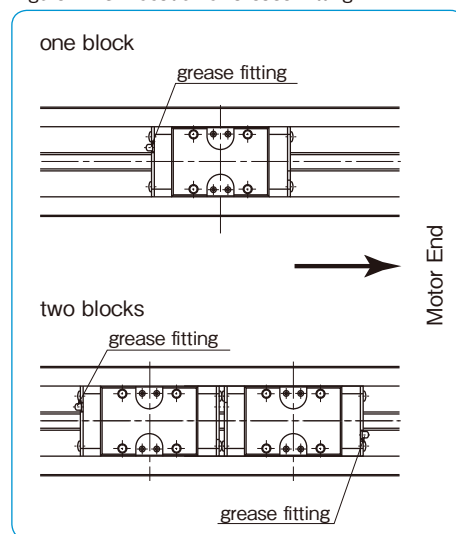

OPERATING TEMPERATURE

- Resin parts are incorporated in the BG type. Please avoid using BG type above 80°C. Please use the product at 55°C or lower when sensor/bellows are optioned.

USE AND HANDLING PRECAUTIONS

- Please handle as a precision component and avoid excessive vibration or shock.
- Rough handling will affect the smooth motion and reduce the precision performance and life time.
- DO NOT DISASSEMBLE. The accuracy of BG type is preadjusted when assembled.
- Please allow for extra stroke length. If the guide block repeatedly collides with damper, it may cause damage.
- Depending upon the operating environment, dust and debris may contaminate BG type and disrupt the ball circulation and precision performance.

MOTOR BRACKET CONFIGURATIONS & APPLICABLE MOTORS

NB provides optional motor brackets to easily install most popular motors.

Table H-13 Applicable Motors

Applicable motors		Part number	BG15	BG20	BG26	BG33	BG46	BG55	
AC Servo motor	Panasonic	MUMA5A	50W	—	A4	A4	B2	—	
		MUMA01	100W	—	—	—	—	—	
		MUMA02	200W	—	—	—	A7	A2	
		MUMA04	400W	—	—	—	—	—	
		MSMA3A	30W	—	A3	A3	A2	C0	
		MSMD (MSMA) 5A	50W	—	—	—	—	—	
		MSMD (MSMA) 01	100W	—	—	—	—	—	
		MSMD (MSMA) 02	200W	—	—	—	A7	A2	
	MSMD (MSMA) 04	400W	—	—	—	—	—		
	MSMD (MSMA) 08	750W	—	—	—	—	A3	A2	
MITSUBISHI ELECTRIC	HC-AQ0135	10W	—	—	—	—	—	—	
	HC-AQ0235	20W	A1	A8	A8	—	—	—	
	HC-AQ0335	30W	—	—	—	—	—	—	
	HF-KP (MP) 053	50W	—	A1	A1	A1	B0	—	
	HF-KP (MP) 13	100W	—	—	—	—	—	—	
	HF-KP (MP) 23	200W	—	—	—	A6	A1	A0	
	HF-KP (MP) 43	400W	—	—	—	—	A4	A1	
	HF-KP (MP) 73	750W	—	—	—	—	—	—	
	HA-FF053	50W	—	—	—	A3	A0	—	
	HA-FF13	100W	—	—	—	—	A3	A2	
HA-FF23	200W	—	—	—	—	—	—		
HA-FF33	300W	—	—	—	—	—	—		
YASKAWA ELECTRIC	SGMM-A131 *	10W	—	—	—	—	—	—	
	SGMM-A231 *	20W	A2	A9	A9	—	—	—	
	SGMM-A331 *	30W	—	—	—	—	—	—	
	SGMAH-A3	30W	—	—	—	—	—	—	
	SGMJV,SGMAV (SGMAS)-A5	50W	—	A1	A1	A1	B0	—	
	SGMJV,SGMAV (SGMAS)-01	100W	—	—	—	—	—	—	
	SGMAV (SGMAS)-C2	150W	—	—	—	A6	A1	A0	
	SGMJV,SGMAV (SGMAS)-02	200W	—	—	—	—	—	—	
	SGMJV,SGMAV (SGMAS)-04	400W	—	—	—	—	A4	A1	
	SGMJV,SGMAV (SGMAS)-08	750W	—	—	—	—	—	—	
SANYO DENKI	Q1AA04003D	30W	—	—	—	—	—	—	
	Q1AA04005D	50W	—	A1	A1	A1	B0	—	
	Q1AA04010D	100W	—	—	—	—	—	—	
	Q1AA06020D	200W	—	—	—	A6	A1	A0	
	Q1AA06040D	400W	—	—	—	—	—	—	
	Q1AA07075D	750W	—	—	—	—	A4	A1	
	Q2AA05005D	50W	—	—	—	—	—	—	
	Q2AA05010D	100W	—	—	—	A3	A0	—	
	Q2AA07020D	200W	—	—	—	—	—	—	
	Q2AA07030D	300W	—	—	—	—	A3	A2	
Q2AA07040D	400W	—	—	—	—	—	—		
Q2AA08050D	500W	—	—	—	—	—	A3		
Q2AA08075D	750W	—	—	—	—	—	—		
ORIENTAL MOTOR	ASC3 *	—	A3	A6	A6	—	—	—	
	CRK51	—	A5	—	—	—	—	—	
	RK (UPK) 54, AS4	—	—	A5	A5	B1	—	—	
	RK (UPK) 56, AS6	—	—	—	—	A4	D0	—	
	RK (UPK) 59, AS9	—	—	—	—	—	—	A4	
	PK26	—	—	—	—	A5	—	—	
	SANYO DENKI	F SERIES □42mm	—	—	A5	A5	B1	—	—
		F SERIES □60mm	—	—	—	—	A4	D0	—
		F SERIES □85mm	—	—	—	—	—	—	A4
	TECHNO DRIVE	* K-S52 *	—	A4	A5	A5	B1	—	—
* K-S54 *		—	—	A5	A5	B1	—	—	
* K-S (M) 56 *		—	—	—	—	A4	D0	—	
* K-M (G) 59 *		—	—	—	—	—	—	A4	

NB can provide other types of motor brackets. Please contact NB for details.

# BG15

Figures inside( ) indicates mass of the motor mount adapter plate.

## Motor Bracket A0

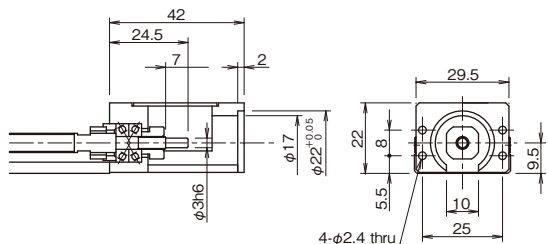

## Adapter Plate A1 (Mass: 9g)

Recommended Coupling: XBW-15C2(Nabeya Bi-tech Kaisha)  
SFC-005DA2(Miki Pully Co., Ltd.)

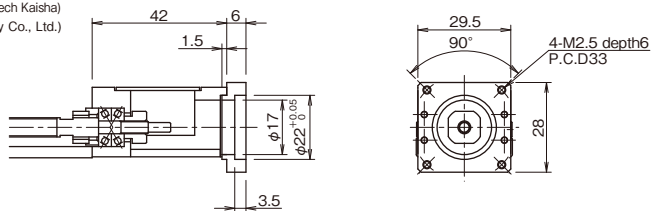

## Adapter Plate A2 (Mass: 8g)

Recommended Coupling: LAD-15C(Sakai Manufacturing Co., Ltd.)  
XBW-15C2(Nabeya Bi-tech Kaisha)  
SFC-005DA2(Miki Pully Co., Ltd.)

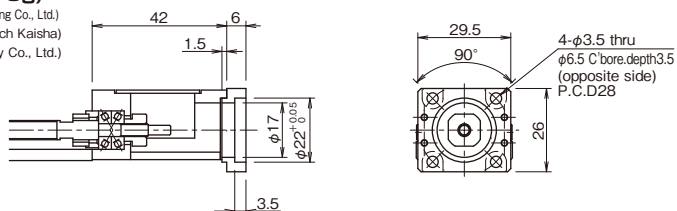

## Adapter Plate A3 (Mass: 9g)

Recommended Coupling: LAD-15C(Sakai Manufacturing Co., Ltd.)  
XBW-15C2(Nabeya Bi-tech Kaisha)  
SFC-005DA2(Miki Pully Co., Ltd.)

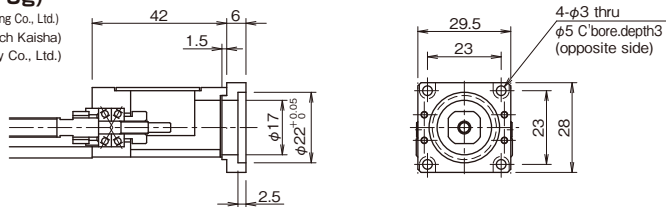

## Adapter Plate A4 (Mass: 8g)

Recommended Coupling: LAD-15C(Sakai Manufacturing Co., Ltd.)  
XBW-15C2(Nabeya Bi-tech Kaisha)  
SFC-005DA2(Miki Pully Co., Ltd.)

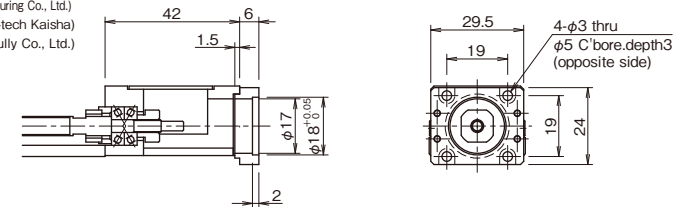

## Adapter Plate A5 (Mass: 4g)

Recommended Coupling: XBW-15C2(Nabeya Bi-tech Kaisha)

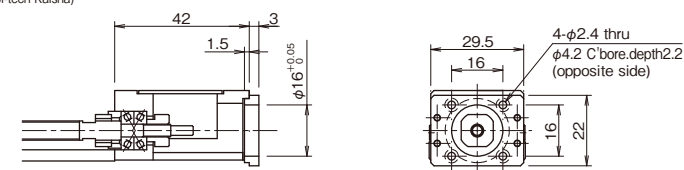

## Adapter Plate A6 (Mass: 4g)

Recommended Coupling: XBW-15C2(Nabeya Bi-tech Kaisha)

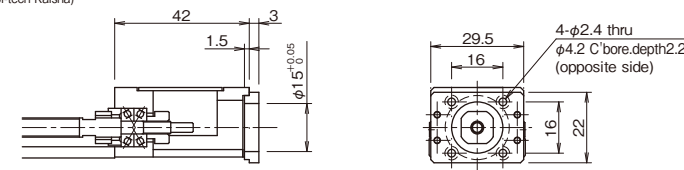

## Adapter Plate A7 (Mass: 11g)

Recommended Coupling: LAD-15C(Sakai Manufacturing Co., Ltd.)  
XBW-15C2(Nabeya Bi-tech Kaisha)

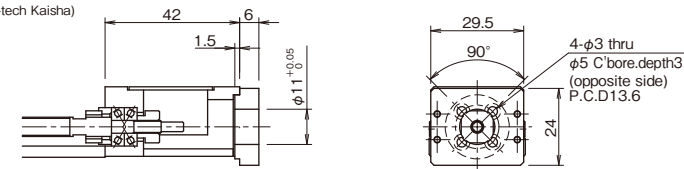

Attach the motor to the motor mount adapter plate first.

# BG20

Figures inside( ) indicates mass of the motor mount adapter plate.

## Motor Bracket A0

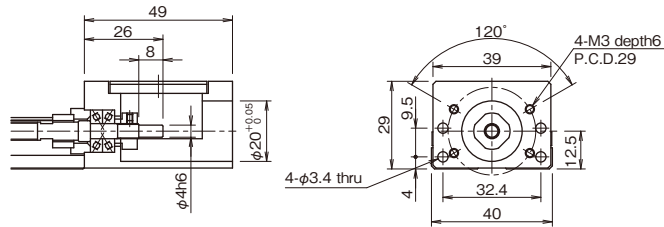

## Adapter Plate A1 (Mass: 38g)

Recommended Coupling: SFC-010DA2(Miki Pulley Co., Ltd.)  
XBW-19C2(Nabeya Bi-tech Kaisha)

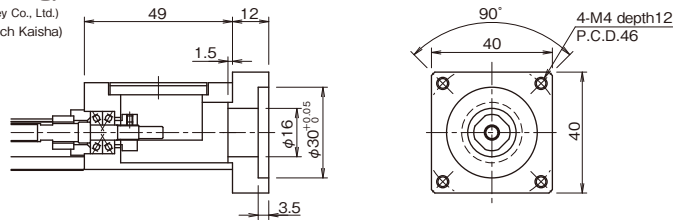

## Adapter Plate A3 (Mass: 39g)

Recommended Coupling: SFC-010DA2(Miki Pulley Co., Ltd.)  
XBW-19C2(Nabeya Bi-tech Kaisha)

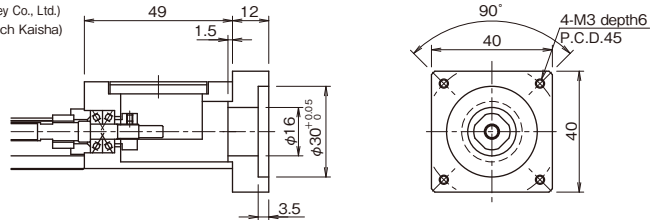

## Adapter Plate A5 (Mass: 26g)

Recommended Coupling: SFC-010DA2(Miki Pulley Co., Ltd.)  
XBW-19C2(Nabeya Bi-tech Kaisha)

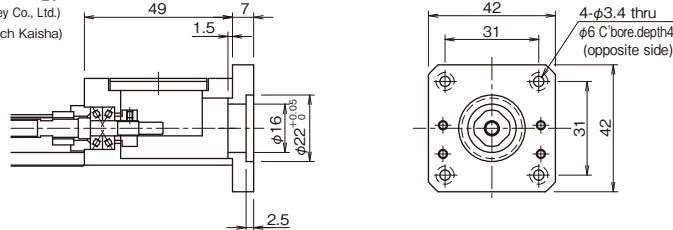

## Adapter Plate A6 (Mass: 10g)

Recommended Coupling: SFC-010DA2(Miki Pulley Co., Ltd.)  
XBW-19C2(Nabeya Bi-tech Kaisha)

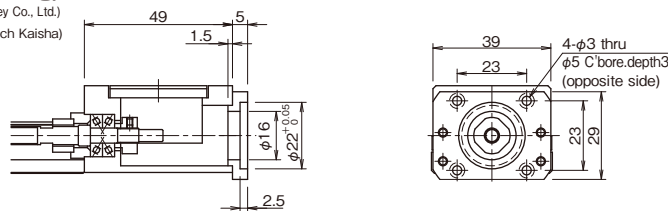

## Adapter Plate A8 (Mass: 12g)

Recommended Coupling: SFC-010DA2(Miki Pulley Co., Ltd.)  
XBW-19C2(Nabeya Bi-tech Kaisha)

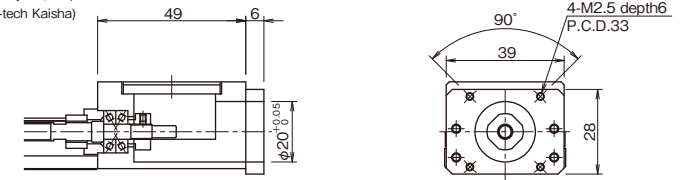

## Adapter Plate A9 (Mass: 14g)

Recommended Coupling: SFC-010DA2(Miki Pulley Co., Ltd.)  
XBW-19C2(Nabeya Bi-tech Kaisha)

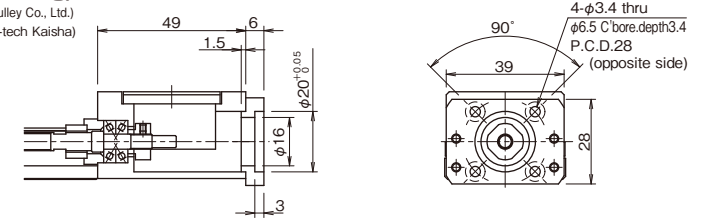

## Adapter Plate AA (Mass: 46g)

Recommended Coupling: SFC-010DA2(Miki Pulley Co., Ltd.)  
XBW-19C2(Nabeya Bi-tech Kaisha)

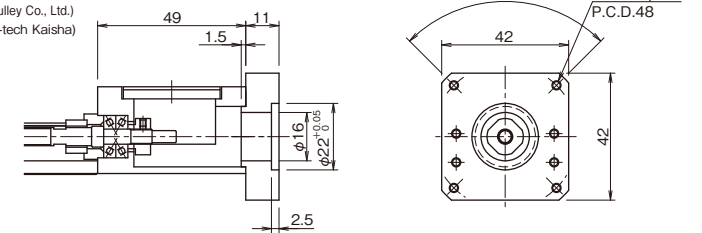

For configurations A5, A6, A9 and AA, attach the motor to the motor mount adapter plate first.

# BG26

Figures inside ( ) indicates mass of the motor mount adapter plate.

## Motor Bracket A0

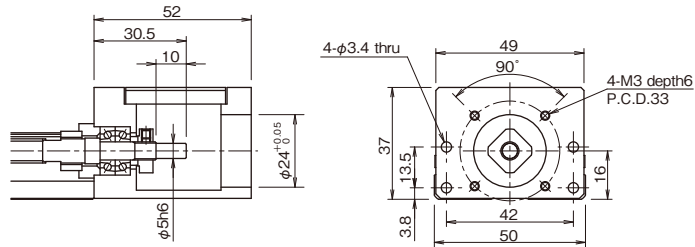

## Adapter Plate A1 (Mass: 28g)

Recommended Coupling: SFC-010DA2(Miki Pulley Co., Ltd.)  
LAD-20C(Sakai Manufacturing Co., Ltd.)  
XBW-19C2(Nabeya Bi-tech Kaisha)

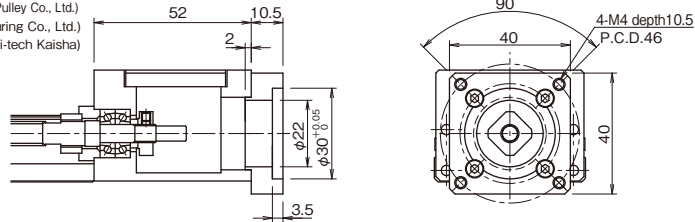

## Adapter Plate A3 (Mass: 24g)

Recommended Coupling: SFC-010DA2(Miki Pulley Co., Ltd.)  
LAD-20C(Sakai Manufacturing Co., Ltd.)  
XBW-19C2(Nabeya Bi-tech Kaisha)

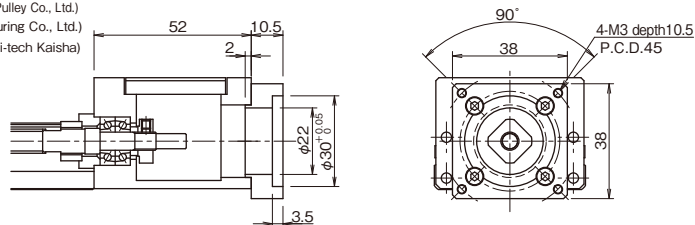

## Adapter Plate A5 (Mass: 32g)

Recommended Coupling: SFC-010DA2(Miki Pulley Co., Ltd.)  
LAD-20C(Sakai Manufacturing Co., Ltd.)  
XBW-19C2(Nabeya Bi-tech Kaisha)

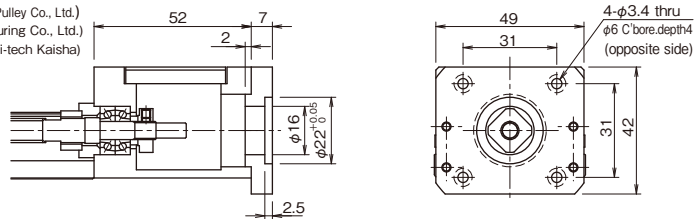

## Adapter Plate A6 (Mass: 16g)

Recommended Coupling: SFC-010DA2(Miki Pulley Co., Ltd.)  
LAD-20C(Sakai Manufacturing Co., Ltd.)  
XBW-19C2(Nabeya Bi-tech Kaisha)

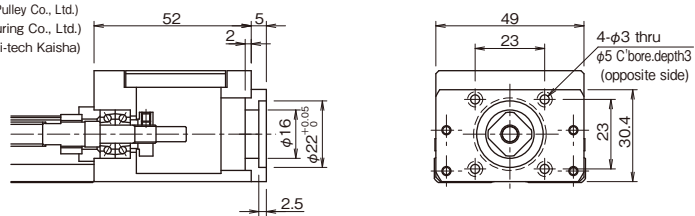

## Adapter Plate A8 (Mass: 21g)

Recommended Coupling: SFC-010DA2(Miki Pulley Co., Ltd.)  
LAD-20C(Sakai Manufacturing Co., Ltd.)  
XBW-19C2(Nabeya Bi-tech Kaisha)

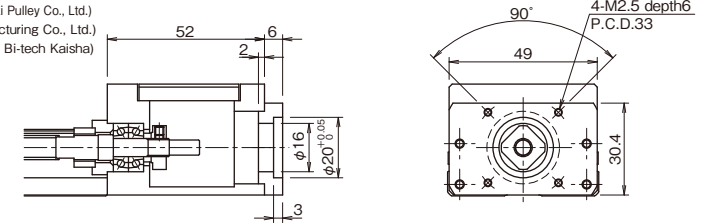

## Adapter Plate A9 (Mass: 21g)

Recommended Coupling: SFC-010DA2(Miki Pulley Co., Ltd.)  
LAD-20C(Sakai Manufacturing Co., Ltd.)  
XBW-19C2(Nabeya Bi-tech Kaisha)

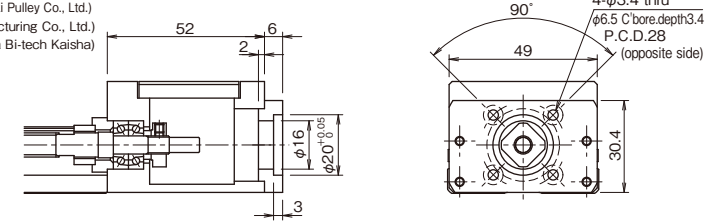

## Adapter Plate AA (Mass: 41g)

Recommended Coupling: SFC-010DA2(Miki Pulley Co., Ltd.)  
LAD-20C(Sakai Manufacturing Co., Ltd.)  
XBW-19C2(Nabeya Bi-tech Kaisha)

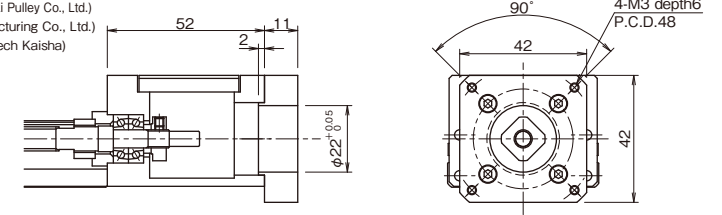

For configurations A5, A6 and A9, attach the motor to the motor mount adapter plate first.

# BG33

Figures inside( ) indicates mass of the motor mount adapter plate.

## Motor Bracket A0

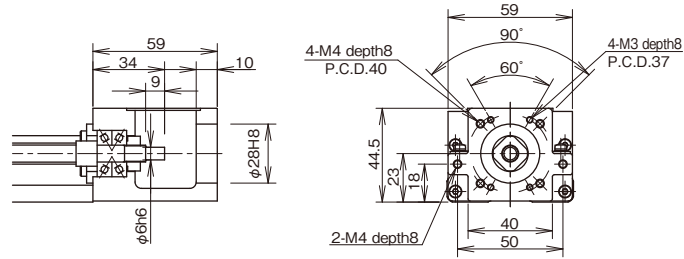

## Adapter Plate A1 (Mass: 66g)

Recommended Coupling: SFC-020DA2(Miki Pulley Co., Ltd.)  
LAD-25C(Sakai Manufacturing Co., Ltd.)  
XBW-25C2(Nabeya Bi-tech Kaisha)

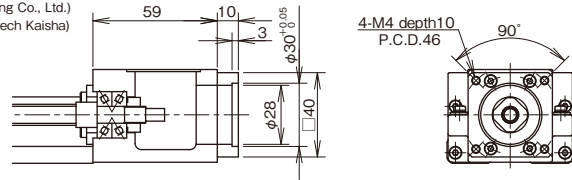

## Adapter Plate A2 (Mass: 67g)

Recommended Coupling: SFC-020DA2(Miki Pulley Co., Ltd.)  
LAD-25C(Sakai Manufacturing Co., Ltd.)  
XBW-25C2(Nabeya Bi-tech Kaisha)

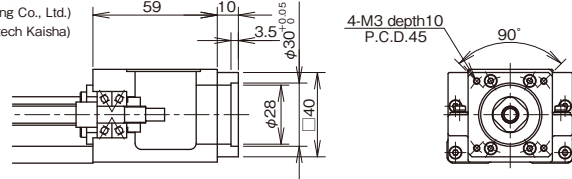

## Adapter Plate A3 (Mass: 133g)

Recommended Coupling: SFC-020DA2(Miki Pulley Co., Ltd.)  
LAD-25C(Sakai Manufacturing Co., Ltd.)  
XBW-25C2(Nabeya Bi-tech Kaisha)

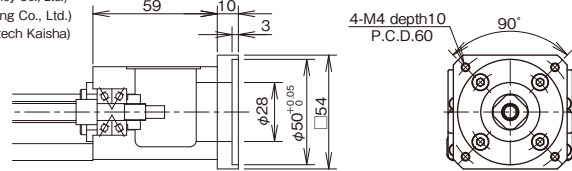

## Adapter Plate A4 (Mass: 212g)

Recommended Coupling: SFC-020DA2(Miki Pulley Co., Ltd.)  
LAD-25C(Sakai Manufacturing Co., Ltd.)  
XBW-25C2(Nabeya Bi-tech Kaisha)

\*Please contact NB when you use αSTEP motor (Oriental Motor Co., Ltd.)

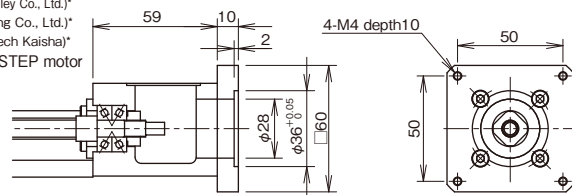

## Adapter Plate A5 (Mass: 125g)

Recommended Coupling: SFC-020DA2(Miki Pulley Co., Ltd.)  
LAD-25C(Sakai Manufacturing Co., Ltd.)  
XBW-25C2(Nabeya Bi-tech Kaisha)

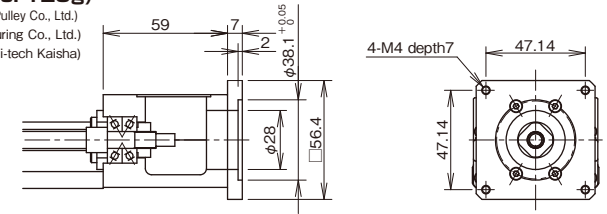

## Adapter Plate A6 (Mass: 215g)

Recommended Coupling: XBW-27C2(Nabeya Bi-tech Kaisha)

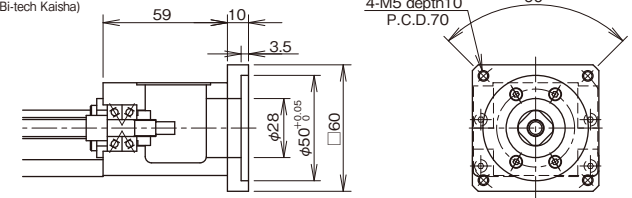

## Adapter Plate A7 (Mass: 215g)

Recommended Coupling: XBW-27C2(Nabeya Bi-tech Kaisha)

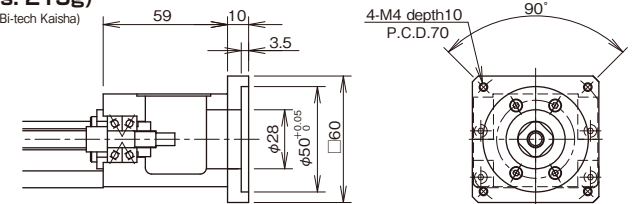

## Adapter Plate B1 (Mass: 111g)

Recommended Coupling: SFC-010DA2(Miki Pulley Co., Ltd.)  
LAD-20C(Sakai Manufacturing Co., Ltd.)  
XBW-19C2(Nabeya Bi-tech Kaisha)

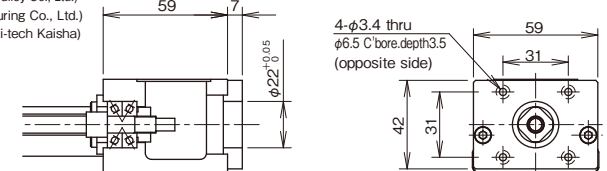

## Adapter Plate B2 (Mass: 167g)

Recommended Coupling: LAD-25C(Sakai Manufacturing Co., Ltd.)  
XBW-19C2(Nabeya Bi-tech Kaisha)

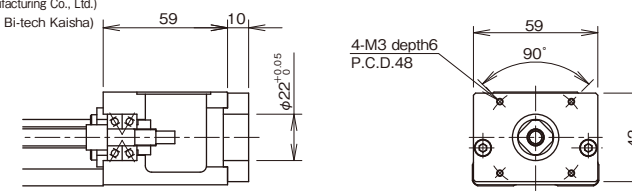

For configurations B1 and B2, attach the motor to the motor mount adapter plate first.

# BG46

Figures inside( ) indicates mass of the motor mount adapter plate.

## Motor Bracket A0

Recommended Coupling: SFC-020DA2(Miki Pulley Co., Ltd.)  
LAD-25C(Sakai Manufacturing Co., Ltd.)  
XBW-25C2(Nabeya Bi-tech Kaisha)

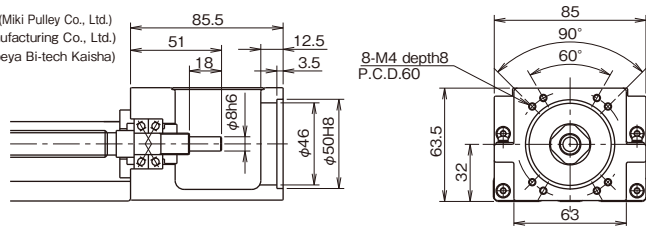

## Motor Bracket B0

Recommended Coupling: SFC-020DA2(Miki Pulley Co., Ltd.)  
LAD-25C(Sakai Manufacturing Co., Ltd.)  
XBW-25C2(Nabeya Bi-tech Kaisha)

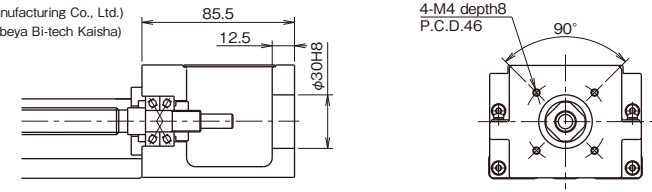

## Adapter Plate A1 (Mass: 103g)

Recommended Coupling: SFC-030DA2(Miki Pulley Co., Ltd.)  
LAD-30C(Sakai Manufacturing Co., Ltd.)  
XBW-34C3(Nabeya Bi-tech Kaisha)

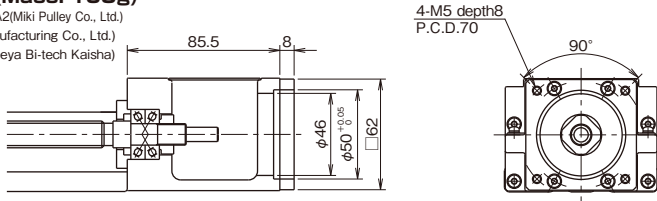

## Motor Bracket C0

Recommended Coupling: SFC-020DA2(Miki Pulley Co., Ltd.)  
LAD-25C(Sakai Manufacturing Co., Ltd.)  
XBW-25C2(Nabeya Bi-tech Kaisha)

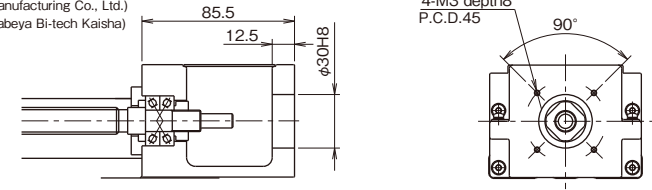

## Adapter Plate A2 (Mass: 106g)

Recommended Coupling: SFC-030DA2(Miki Pulley Co., Ltd.)  
LAD-30C(Sakai Manufacturing Co., Ltd.)  
XBW-34C3(Nabeya Bi-tech Kaisha)

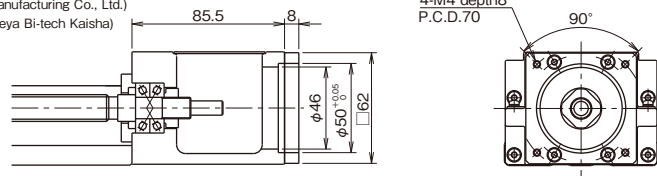

## Motor Bracket D0

Recommended Coupling: SFC-020DA2(Miki Pulley Co., Ltd.)  
LAD-25C(Sakai Manufacturing Co., Ltd.)  
XBW-27C2(Nabeya Bi-tech Kaisha)  
\*Please contact NB when you use αSTEP motor (Oriental Motor Co., Ltd.).

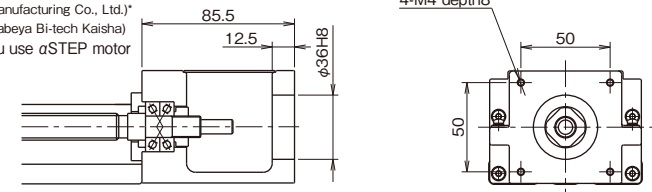

## Adapter Plate A3 (Mass: 448g)

Recommended Coupling (200W-400W): SFC-030DA2(Miki Pulley Co., Ltd.)  
XBW-34C3(Nabeya Bi-tech Kaisha)  
(750W): SFC-040DA2(Miki Pulley Co., Ltd.)  
XBW-39C2(Nabeya Bi-tech Kaisha)

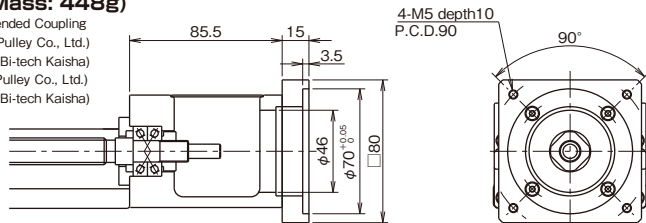

## Adapter Plate A4 (Mass: 628g)

Recommended Coupling: SFC-040DA2(Miki Pulley Co., Ltd.)  
XBW-39C2(Nabeya Bi-tech Kaisha)

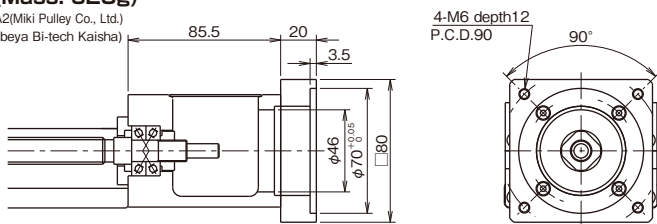

# BG55

Figures inside( ) indicates mass of the motor mount adapter plate.

## Motor Bracket A0

Recommended Coupling: SFC-035DA2(Miki Pulley Co., Ltd.)  
LAD-35C(Sakai Manufacturing Co., Ltd.)  
XBW-34C3(Nabeya Bi-tech Kaisha)

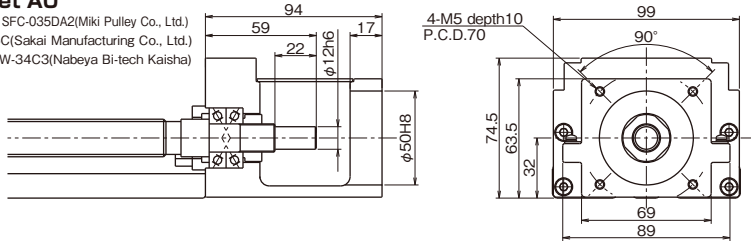

## Adapter Plate A1 (Mass: 329g)

Recommended Coupling: SFC-040DA2(Miki Pulley Co., Ltd.)  
LAD-40C(Sakai Manufacturing Co., Ltd.)  
XBW-39C2(Nabeya Bi-tech Kaisha)

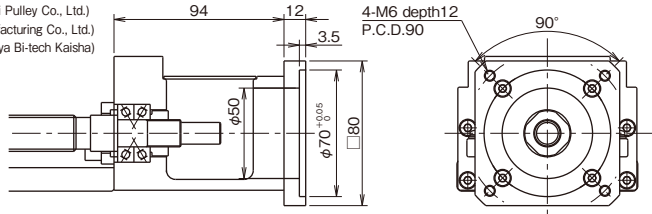

## Adapter Plate A2 (Mass: 333g)

Recommended Coupling: SFC-040DA2(Miki Pulley Co., Ltd.)  
LAD-40C(Sakai Manufacturing Co., Ltd.)  
XBW-39C2(Nabeya Bi-tech Kaisha)

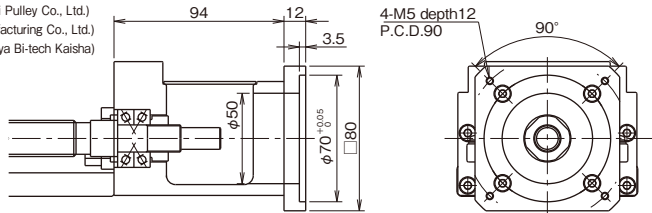

## Adapter Plate A3 (Mass: 399g)

Recommended Coupling: SFC-040DA2(Miki Pulley Co., Ltd.)  
LAD-40C(Sakai Manufacturing Co., Ltd.)  
XBW-39C2(Nabeya Bi-tech Kaisha)

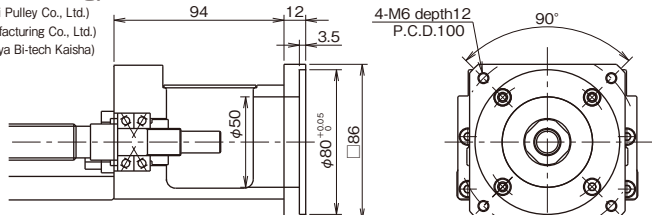

## Adapter Plate A4 (Mass: 449g)

Recommended Coupling: SFC-035DA2(Miki Pulley Co., Ltd.)  
LAD-35C(Sakai Manufacturing Co., Ltd.)  
XBW-34C3(Nabeya Bi-tech Kaisha)

\*Please contact NB when you use αSTEP motor (Oriental Motor Co., Ltd.).

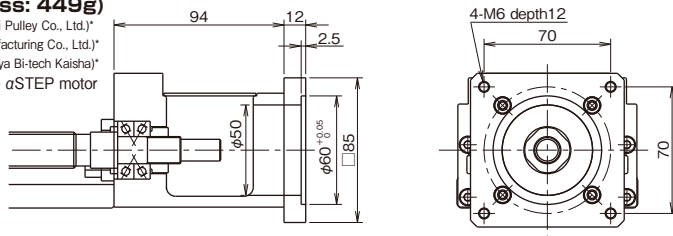

# EXPOSED BRACKET R0

The ball screw shaft end is exposed with the exposed bracket R0 type.  
Please fabricate an original bracket in case the standard brackets are not applicable.

## BG15 Exposed Bracket R0

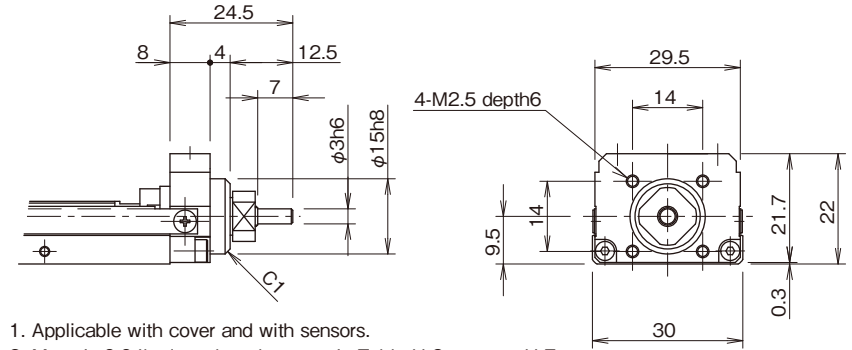

1. Applicable with cover and with sensors.
2. Mass is 0.04kg less than the mass in Table H-3 on page H-7.

## BG20 Exposed Bracket R0

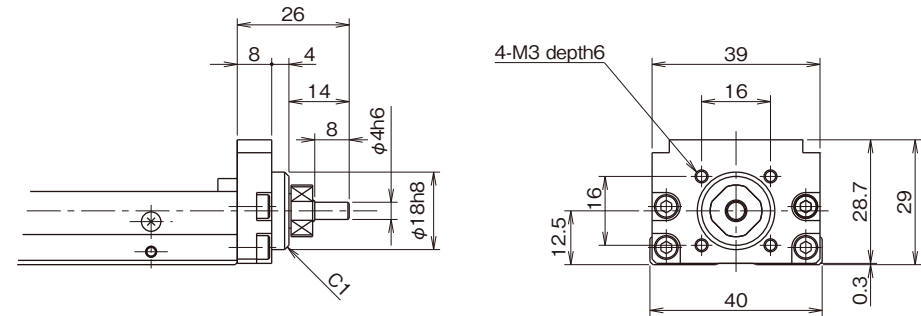

1. Applicable with cover and with sensors.
2. Mass is 0.04kg less than the mass in Table H-3 on page H-7.

**BG26 Exposed Bracket R0**

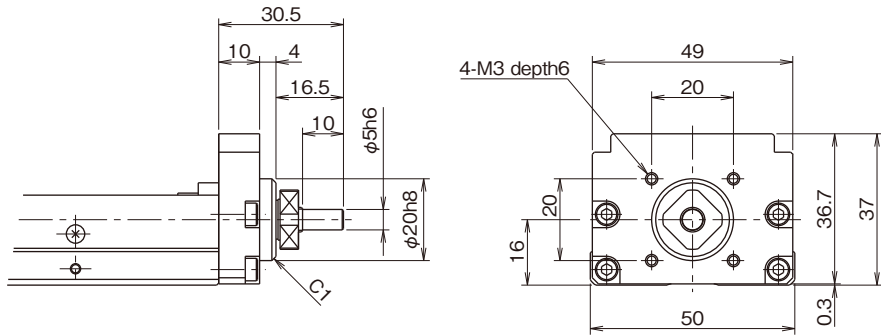

1. Applicable with cover and with sensors.
2. Mass is 0.08kg less than the mass in Table H-3 on page H-7.

**BG46 Exposed Bracket R0**

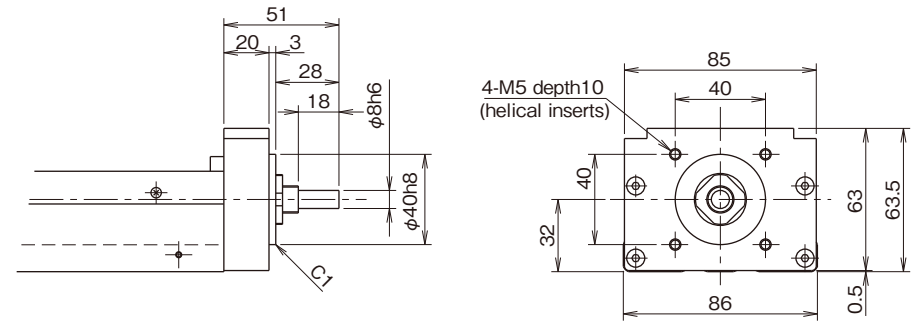

1. Applicable with cover and with sensors.
2. Mass is 0.3kg less than the mass in Table H-3 on page H-7.

**BG33 Exposed Bracket R0**

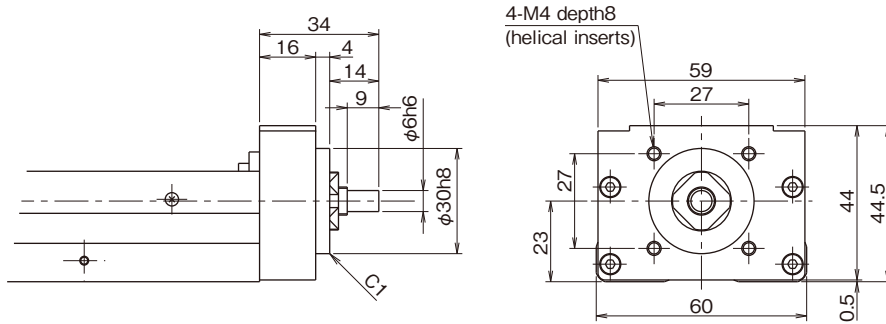

1. Applicable with cover and with sensors.
2. Mass is 0.1kg less than the mass in Table H-3 on page H-7.

**BG55 Exposed Bracket R0**

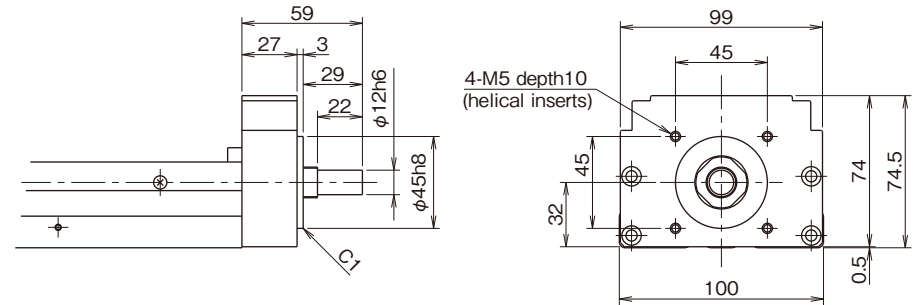

1. Applicable with cover and with sensors.
2. Mass is 0.3kg less than the mass in Table H-3 on page H-7.

RETURN PULLEY UNIT

Return pulley units in which a motor is connected with a timing belt are available for BG type. Its return structure allows the reduction of total length (available for BG33 and BG46).

BG33 Return Pulley Unit

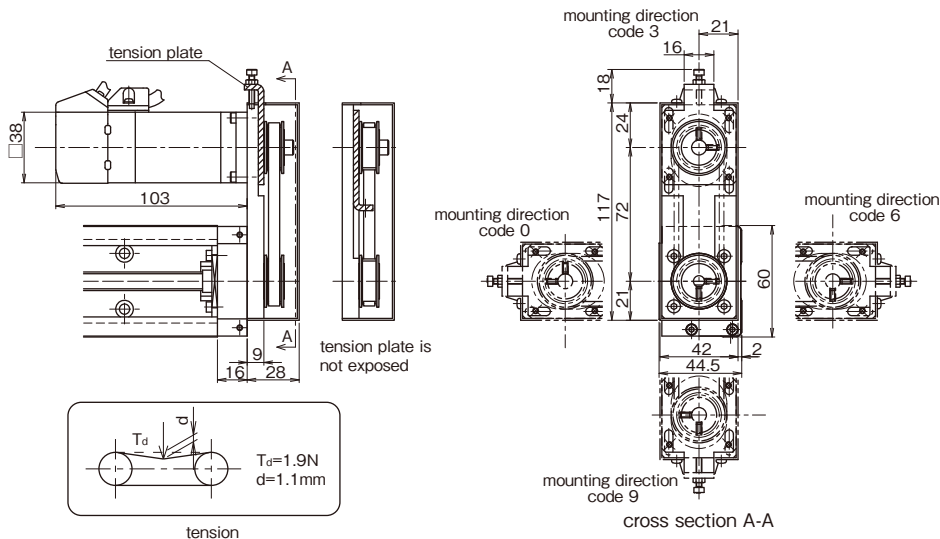

- 1.This drawing shows RA for MSMA01(Panasonic).
- 2.Installation position of Pulley Unit can be selected at 90° intervals (mounting direction code).
- 3.Applicable with cover and with sensors.
- 4.Tension plate can be built in and is not exposed. (not applicable to RC)
- 5.Mass is added 0.2kg to the mass in Table H-3, page H-7.
- 6.Inertia is added  $2.22 \times 10^{-6} \text{kg} \cdot \text{m}^2$  to the value of Table H-5, page H-8. (motor inertia not included)
- 7.Part number structure BG33\*\*\*-\*\*\*\*/☆☆□  
☆☆: Symbol of applicable motor bracket (refer to Table H-14)  
□: Mounting direction code (refer to cross section A-A)

Table H-14 Applicable Motor

motor bracket	applicable motors	
RA	Panasonic	MINAS □38 SERIES:50~100W
	YASKAWA ELECTRIC	SIGMA SERIES:50~100W
	MITSUBISHI ELECTRIC	HC-MF SERIES:50~100W
RB	SANYO DENKI	Q1 SERIES:50~100W
	RC	5 PHASE STEPPING MOTOR □42 SERIES

Please contact NB for other stepper motors.

BG46 Return Pulley Unit

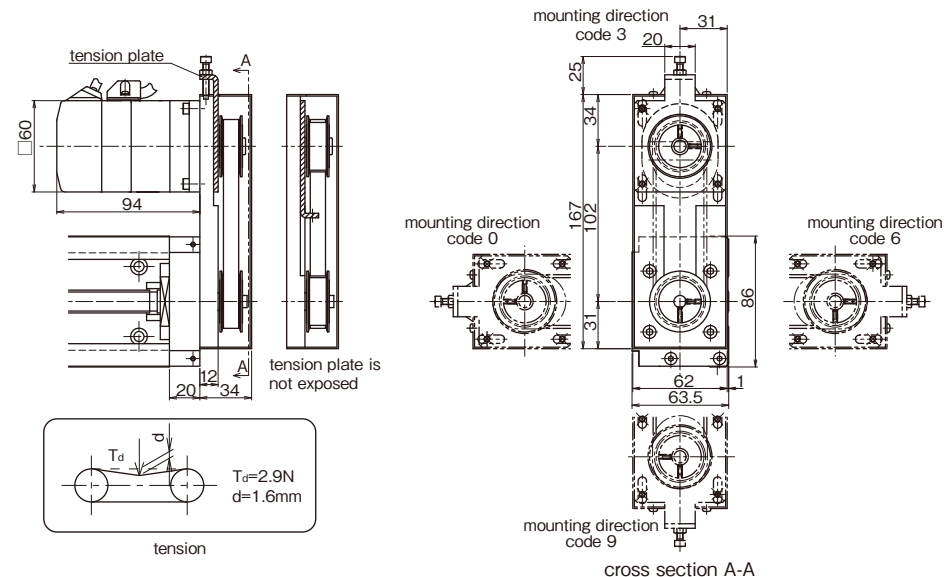

- 1.This drawing shows RA for MSMA01(Panasonic).
- 2.Installation position of Pulley Unit can be selected at 90° intervals (mounting direction code).
- 3.Applicable with cover and with sensors.
- 4.Tension plate can be built in and is not exposed.
- 5.Mass is added 0.7kg to the value in Table H-3, page H-7.
- 6.Inertia is added  $1.24 \times 10^{-5} \text{kg} \cdot \text{m}^2$  to the value of Table H-5, page H-8. (motor inertia not included)
- 7.Parts number structure BG46\*\*\*-\*\*\*\*/☆☆□  
☆☆: Symbol of applicable motor bracket (refer to Table H-15)  
□: Mounting direction code (refer to cross section A-A)

Table H-15 Applicable Motor

motor bracket	applicable motors	
RA	Panasonic	MINAS SERIES:200W
	YASKAWA ELECTRIC	SIGMA SERIES:200W
RB	MITSUBISHI ELECTRIC	HC-MF SERIES:200W
	SANYO DENKI	Q1 SERIES:200W
RC	5 PHASE STEPPING MOTOR	□60 SERIES

Please contact NB for other stepper motors.

SENSOR

Photomicro sensor or proximity sensor can be attached to the BG actuator with our optional sensor-mounting rail (the same length as the guide rail length). Tapped holes are machined on both sides of the guide rail, allowing attachment of sensor to either side. Standard positioning (without special instruction from customer) would be to the left of the motor mount end. Sensor option includes the items that are listed below.

BG15

K Specification (Proximity Sensor)

—Without Top Cover—

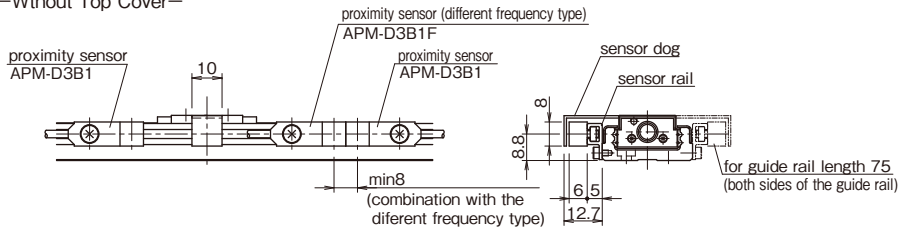

—With Top Cover—

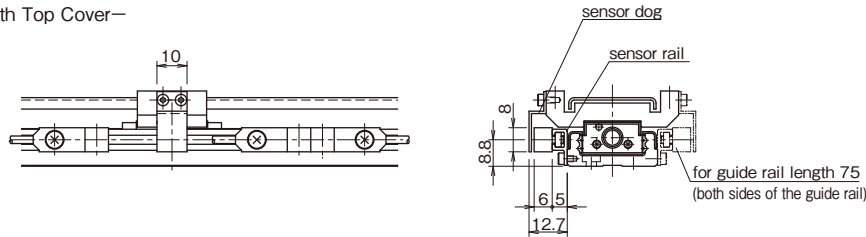

- accessories  
 proximity sensor (APM-D3B1, YAMATAKE) 2 pcs  
 proximity sensor (different frequency type)(APM-D3B1F, YAMATAKE) 1 pc  
 sensor rail 1 pc  
 sensor dog 1 pc  
 \*2 pcs of sensor dogs for BG15A-75  
 (refer to the picture on the right.)

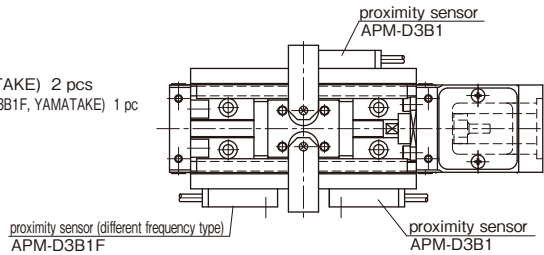

BG20

S Specification (Compact Photomicro Sensor)

—Without Top Cover—

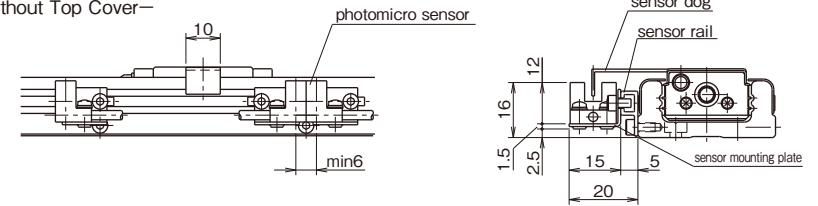

—With Top Cover—

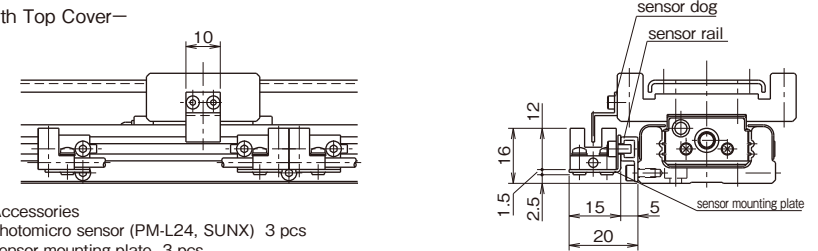

- Accessories  
 photomicro sensor (PM-L24, SUNX) 3 pcs  
 sensor mounting plate 3 pcs  
 sensor rail 1 pc  
 sensor dog 1 pc

K Specification (Proximity Sensor)

—Without Top Cover—

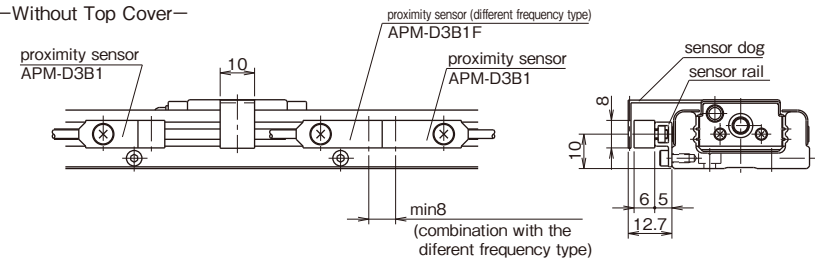

—With Top Cover—

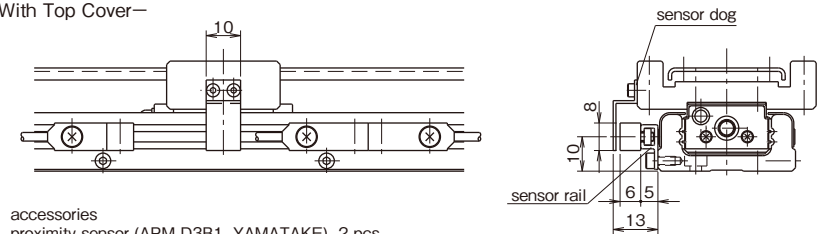

- accessories  
 proximity sensor (APM-D3B1, YAMATAKE) 2 pcs  
 proximity sensor (different frequency type)(APM-D3B1F, YAMATAKE) 1 pc  
 sensor rail 1 pc  
 sensor dog 1 pc

BG26

**S Specification (Compact Photomicro Sensor)**

—Without Top Cover—

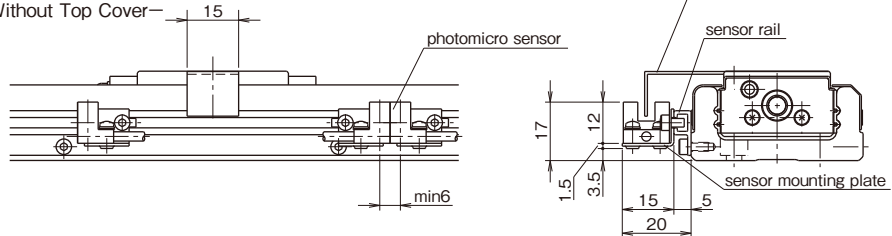

—With Top Cover—

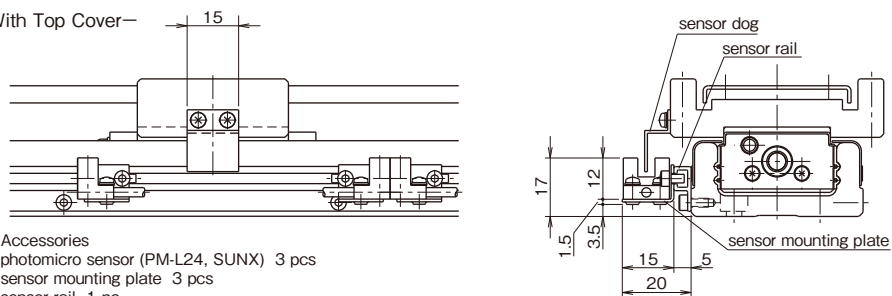

- Accessories  
 photomicro sensor (PM-L24, SUNX) 3 pcs  
 sensor mounting plate 3 pcs  
 sensor rail 1 pc  
 sensor dog 1 pc

**K Specification (Proximity Sensor)**

—Without Top Cover—

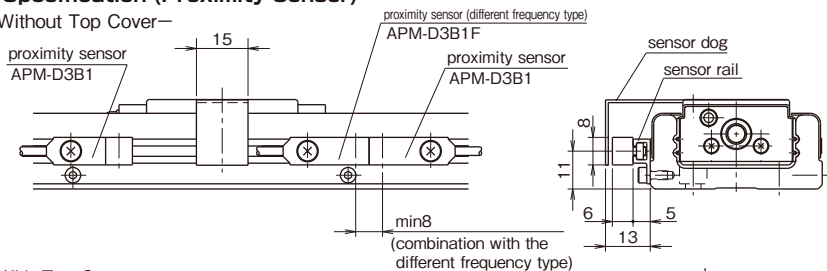

—With Top Cover—

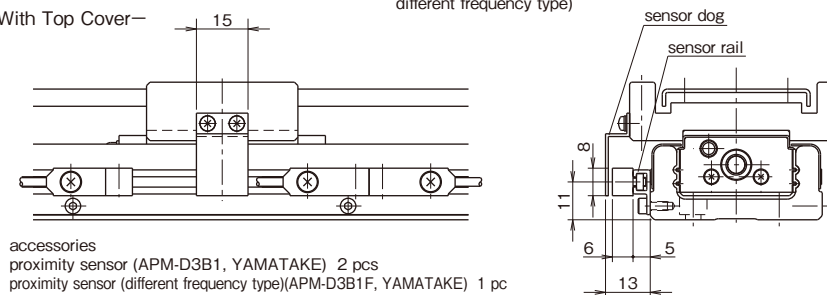

- accessories  
 proximity sensor (APM-D3B1, YAMATAKE) 2 pcs  
 proximity sensor (different frequency type)(APM-D3B1F, YAMATAKE) 1 pc  
 sensor rail 1 pc  
 sensor dog 1 pc

BG33

**S Specification (Slim-Type Photomicro Sensor)**

—Without Top Cover—

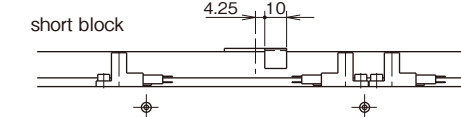
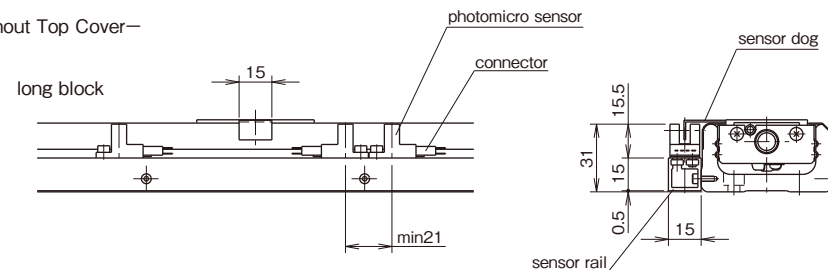

—With Top Cover—

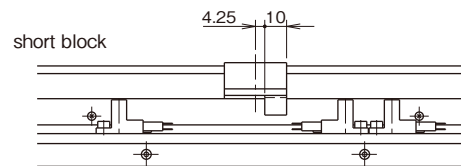
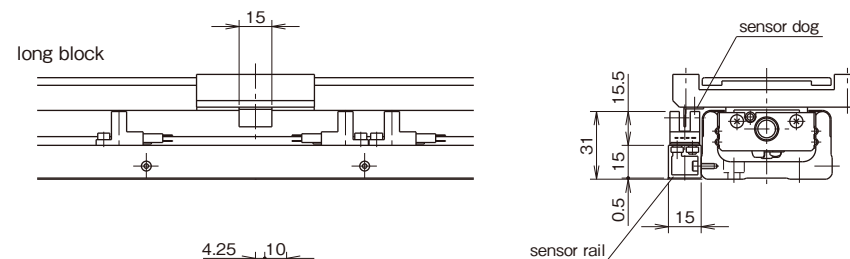

- accessories  
 photomicro sensor (EE-SX674, OMRON) 3 pcs  
 connector (EE-1001, OMRON) 3 pcs  
 sensor rail 1 pc  
 sensor dog \*1 pc  
 \* 2 pcs for BG33D-150.

BG33

H Specification (Close Contact Capable Photomicro Sensor)

—Without Top Cover—

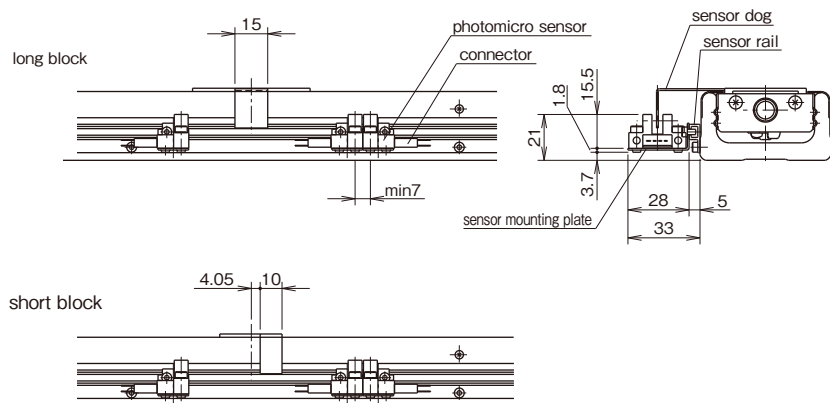

—With Top Cover—

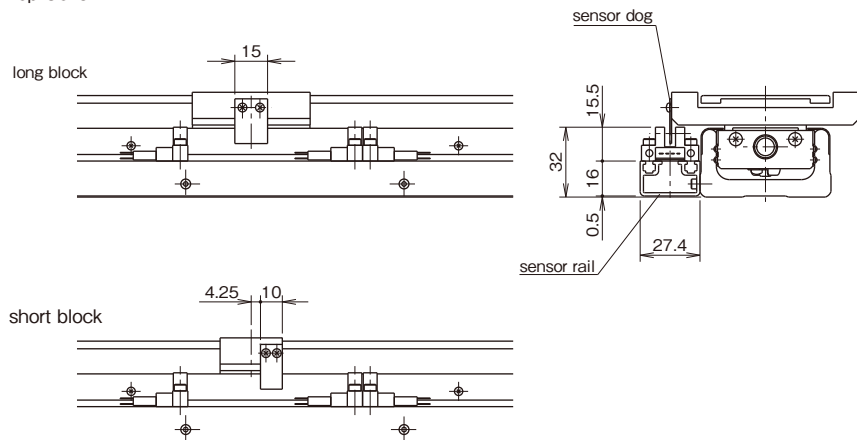

- accessories  
 photomicro sensor (EE-SX671, OMRON) 3 pcs  
 connector (EE-1001, OMRON) 3 pcs  
 sensor mounting plate (only for the without cover type) 3 pcs  
 sensor rail 1 pc  
 sensor dog \*1 pcs  
 \* 2 pcs for BG33D-150.

BG33

K Specification (Proximity Sensor)

—Without Top Cover—

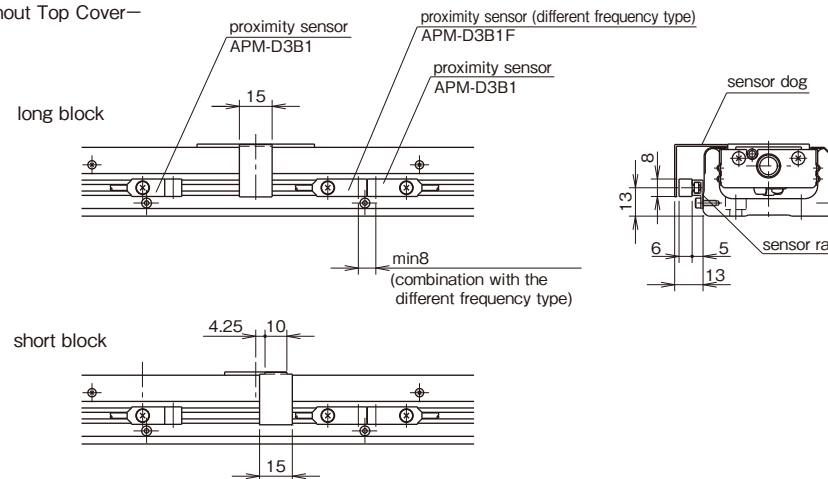

—With Top Cover—

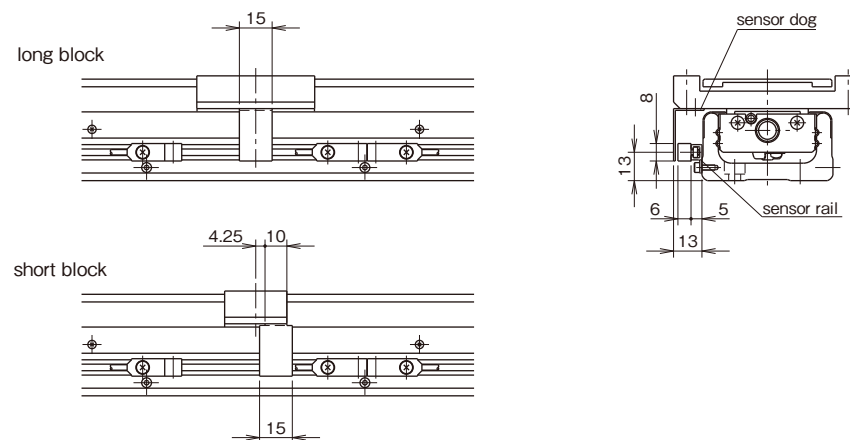

- accessories  
 proximity sensor (APM-D3B1, YAMATAKE) 2 pcs  
 proximity sensor (different frequency type)(APM-D3B1F, YAMATAKE) 1 pc  
 sensor rail 1 pc  
 sensor dog \*1 pc  
 \* 2 pcs for BG33D-150.

BG46

S Specification (Slim-Type Photomicro Sensor)

—Without Top Cover—

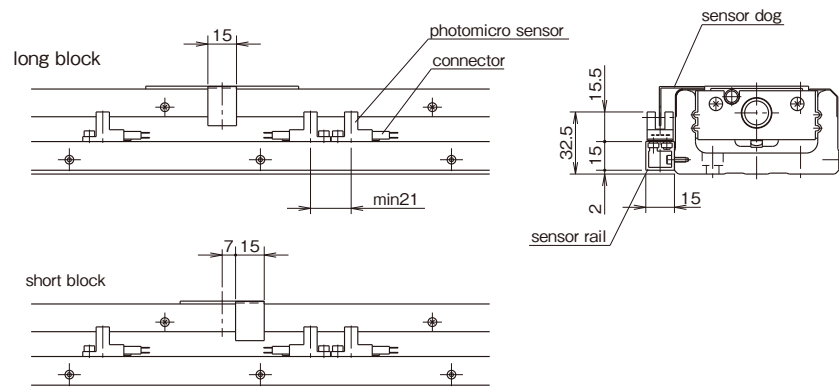

—With Top Cover—

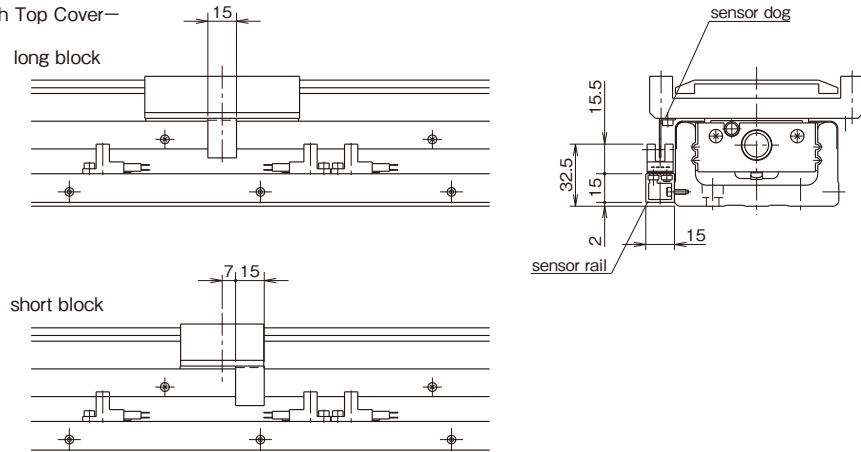

- accessories  
 photomicro sensor (EE-SX674, OMRON) 3 pcs  
 connector (EE-1001, OMRON) 3 pcs  
 sensor rail 1 pc  
 sensor dog 1 pc

BG46

H Specification (Close Contact Capable Photomicro Sensor)

—Without Top Cover—

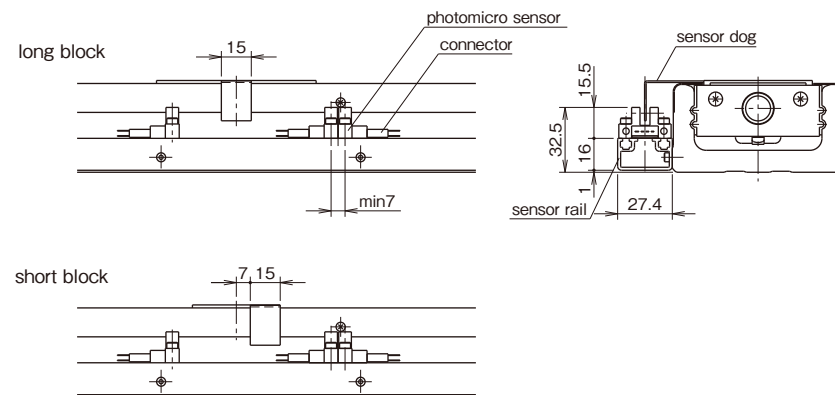

—With Top Cover—

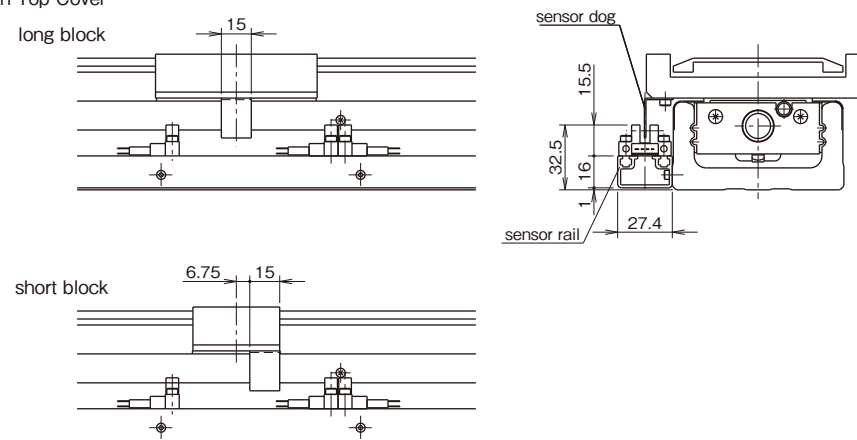

- accessories  
 photomicro sensor (EE-SX671, OMRON) 3 pcs  
 connector (EE-1001, OMRON) 3 pcs  
 sensor rail 1 pc  
 sensor dog 1 pc

BG46

K Specification (Proximity Sensor)

—Without Top Cover—

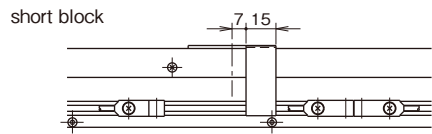
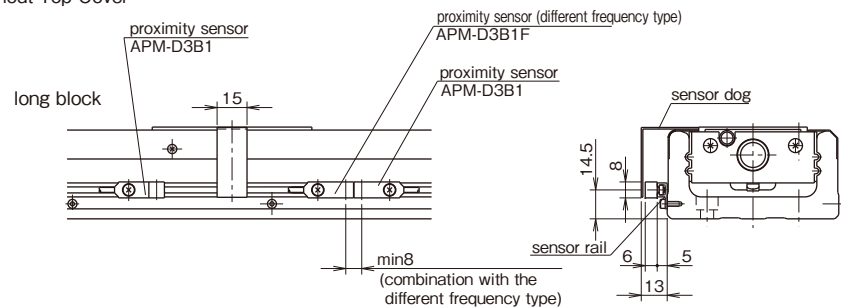

—With Top Cover—

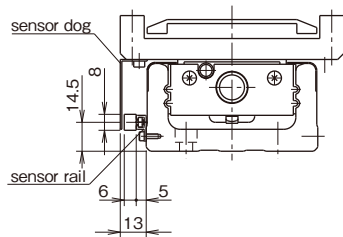
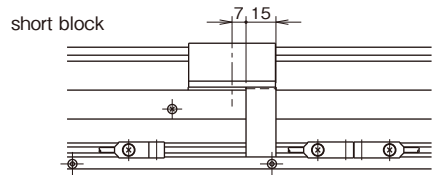
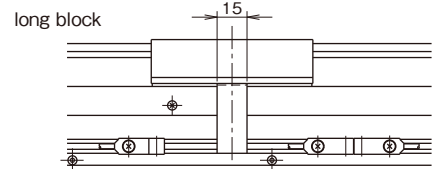

- accessories  
 proximity sensor (APM-D3B1, YAMATAKE) 2 pcs  
 proximity sensor (different frequency type)(APM-D3B1F, YAMATAKE) 1 pc  
 sensor rail 1 pc  
 sensor dog 1 pc

BG55

S Specification (Compact Photomicro Sensor)

—Without Top Cover—

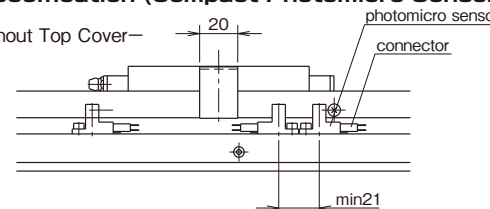

—With Top Cover—

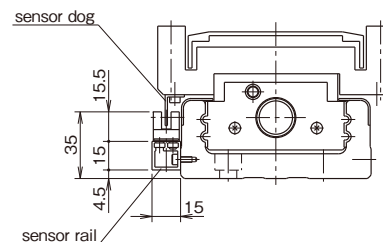
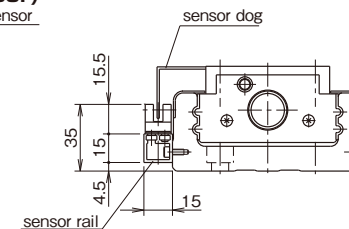
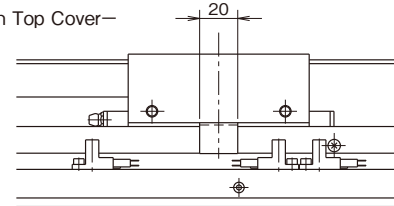

- accessories  
 photomicro sensor (EE-SX674, OMRON) 3 pcs  
 connector (EE-1001, OMRON) 3 pcs  
 sensor rail 1 pc  
 sensor dog 1 pc

H Specification (Close Contact Capable Photomicro Sensor)

—Without Top Cover—

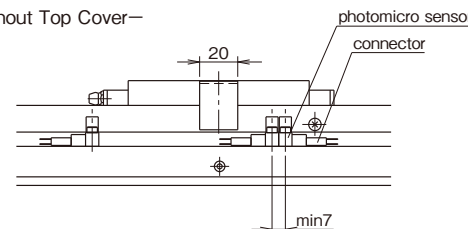

—With Top Cover—

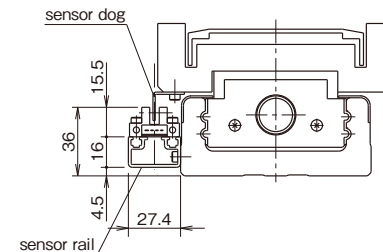
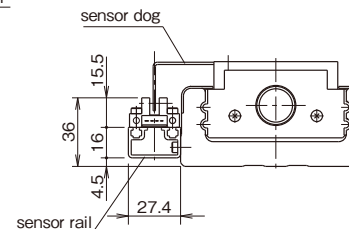
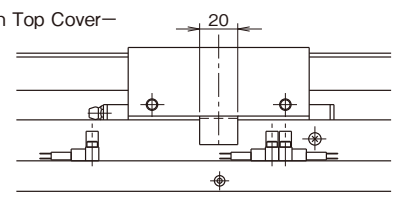

- accessories  
 photomicro sensor (EE-SX671, OMRON) 3 pcs  
 connector (EE-1001, OMRON) 3 pcs  
 sensor rail 1 pc  
 sensor dog 1 pc

BG55

K Specification (Proximity Sensor)

—Without Top Cover—

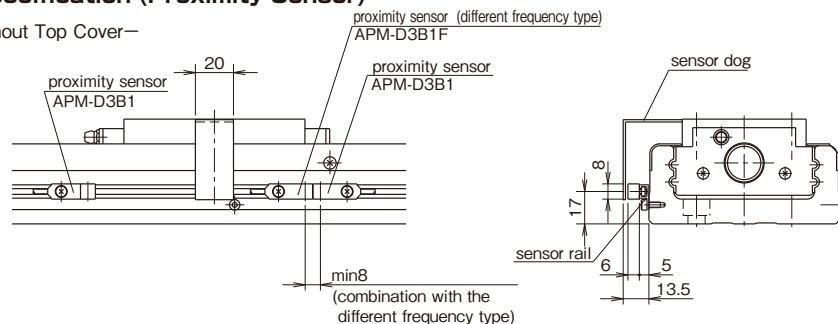

—With Top Cover—

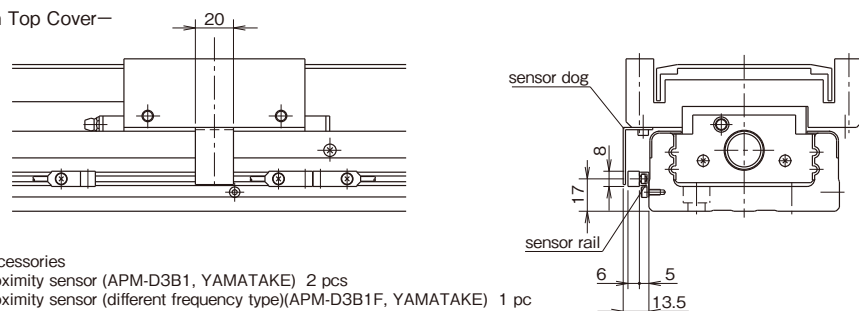

- accessories  
 proximity sensor (APM-D3B1, YAMATAKE) 2 pcs  
 proximity sensor (different frequency type)(APM-D3B1F, YAMATAKE) 1 pc  
 sensor rail 1 pc  
 sensor dog 1 pc

PNP Sensor

For the BG type sensors can be changed to the PNP type by adding a sensor option code "PNP" at the end of the part number.

Refer to Table H-16 for the model number of PNP type sensors.

Table H-16 Sensor Type

sensor code	sensor type	applicable model type	standard specification	PNP specification model type
S	slim-type photomicro sensor	BG33, BG46, BG55	EE-SX674	EE-SX674P
	compact photomicro sensor	BG20, BG26	PM-L24	PM-L24P
H	close contact capable photomicro sensor	BG33, BG46, BG55	EE-SX671	EE-SX671P
K	proximity sensor	all model types	APM-D3B1	APM-D3E1
	proximity sensor (different frequency type)	all model types	APM-D3B1F	APM-D3E1F

SENSOR SPECIFICATIONS

slim-type, close contact capable photomicro sensor (symbol: S,H)/ OMRON CORPORATION

type	NPN TYPE	EE-SX674	EE-SX671
	PNP TYPE	EE-SX674P	EE-SX671P
sensing distance	5mm (slot width)		
standard sensing object	opaque: 2×0.8mm min.		
differential travel	0.025mm		
power supply voltage	5 to 24 VDC ±10% , ripple(P-P): 10% max.		
current consumption	35mA max. (NPN), 30 mA max.(PNP)		
control output	NPN TYPE	NPN open collector output models: At 5 to 24 VDC: 100-mA load current (Ic) with a residual voltage of 0.8V max.40-mA load current (Ic) with a residual voltage of 0.4V max.	
	PNP TYPE	PNP open collector output models: At 5 to 24 VDC: 50-mA load current (Ic) with a residual voltage of 1.3V max.	
output operation	Dark-On (+, L terminal open-circuit), Light-On (+, L terminal short-circuit)		
response frequency	1kHz max. (3kHz average)		
operation indicator	operation indicator (red) lit with incident		
ambient illumination (on receiver lens)	fluorescent light: 1000 lx max.		
ambient temperature	operating: -25 to 55°C storage: -30 to 80°C		
ambient humidity	operating: 5 to 85% RH storage: 5 to 95% RH		
vibration resistance	destruction: 20 to 2000Hz, (with a peak acceleration of 100m/s <sup>2</sup> ) 1.5mm double amplitude for 2hrs (with 4-minute cycles) each in X,Y, and Z directions		
shock resistance	destruction: 500m/s <sup>2</sup> for 3 times each in X,Y, and Z directions		
degree of protection	IEC60529 IP50		
connection method	connector type (direct soldering possible)		
weight	approx. 3g		
material	case	Polybutylene phthalate (PBT)	
	cover	Polycarbonate (PC)	
	emitter/receiver	Polycarbonate (PC)	

NPN TYPE CIRCUIT DIAGRAM

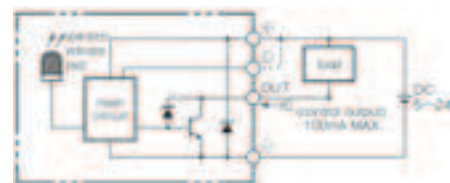

PNP TYPE CIRCUIT DIAGRAM

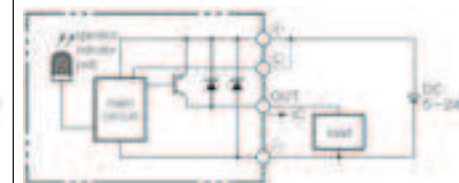

Please read the specifications and precautions of the manufacturer's catalog.

compact photomicro sensor (symbol: S)/ SUNX LIMITED

type	NPN TYPE	PM-L24
	PNP TYPE	PM-L24P
sensing range	5mm (fixed)	
minimum sensing object	0.8×1.8mm min. opaque	
hysteresis	0.05mm or less	
repeatability	0.03mm or less	
supply voltage	5 to 24 VDC ±10% , ripple(P-P) 10% or less	
current consumption	15mA or less	
output	NPN TYPE	NPN open-collector transistor maximum sink current: 50mA, applied voltage: 30VDC or less (between output and 0V) residual voltage: 0.7V or less (at 50mA sink current) 0.4V or less (at 16mA sink current)
	PNP TYPE	PNP open-collector transistor maximum source current: 50mA, applied voltage: 30VDC or less (between output and +V) residual voltage: 0.7V or less (at 50mA sink current) 0.4V or less (at 16mA sink current)
output operation	Incorporated with 2 outputs: Light-ON/Dark-ON	
response time	under light received condition: 20μs or less under light interrupted condition: 100μs or less (response frequency: 1kHz or more)	
operation indicator	vermilion LED (lights up under light received condition)	
ambient illuminance	fluorescent light: 1000lx at the light-receiving face	
ambient temperature	operating: -25 to 55°C (No dew condensation or icing allowed.) storage: -30 to 80°C	
ambient humidity	35 to 85% RH storage: 35 to 85% RH	
voltage withstandability	1000V AC for one min. between all supply terminals connected together and enclosure	
insulation resistance	50MΩ, or more, with 250V DC megger between all supply terminals connected together and enclosure	
vibration resistance	10 to 2,000Hz frequency, 1.5mm amplitude in X, Y, and Z directions for two hours each	
shock resistance	15,000m/s <sup>2</sup> acceleration (1,500 G approx.) in X, Y, and Z directions for three times each	
cable	0.09mm <sup>2</sup> 4-core cabtyre cable 1m long	
weight	approx. 10g	
material	case	Polybutylene phthalate (PBT)
	cover	Polycarbonate

NPN TYPE  
CIRCUIT DIAGRAM

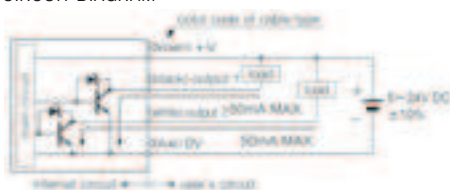

PNP TYPE  
CIRCUIT DIAGRAM

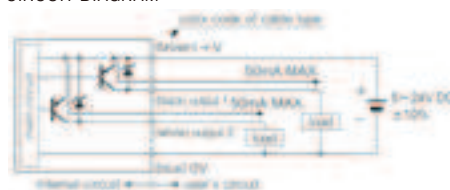

Please read the specifications and precautions of the manufacturer's catalog.

proximity sensor (symbol: K)/ YAMATAKE CORPORATION

type	NPN TYPE	APM-D3B1,APM-D3B1F(different-frequency type)
	PNP TYPE	APM-D3E1,APM-D3E1F(different-frequency type)
rated sensing distance	2.5mm±15%	
standard target object	15×15mm, 1mm thick iron	
differential travel	15% max. of sensing distance	
rated supply voltage	12/24VDC	
operating voltage range	10.8 to 26.4 VDC (ripple voltage 10% max.)	
current consumption	10mA max.	
control output	NPN TYPE	NPN transistor open collector switching current: 30mA max. (resistive load) voltage drop: 1V max. (switching current 30mA) output dielectric strength: 26.4V
	PNP TYPE	PNP transistor open collector switching current: 30mA max. (resistive load) voltage drop: 1V max. (switching current 30mA) output dielectric strength: 26.4V
operation mode	normally closed (N.C.)	
operating frequency	120Hz	
indicator lamps	lights (red) when object approaches	
operating temperature range	-10 to 55°C storage: -25 to 70°C	
operating humidity range	35 to 85% RH	
ambient illumination(on receiver lens)	fluorescent light: 1000lxmax.	
dielectric strength	1000V AC (50/60Hz) for one min. between case and electrically live metals	
insulation resistance	50MΩ min. (by 500V DC megger )	
vibration resistance	10 to 55Hz, 1.5mm peak-to-peak amplitude, 2hrs in X, Y, and Z directions	
voltage withstandability	1000V AC(50/60Hz) for one min. between all supply terminals connected together and enclosure	
insulation resistance	50MΩ, or more( with 500V DC megger )	
shock resistance	500m/s <sup>2</sup> 3 times in Y,Y, and Z directions	
protection	IP67 (IEC 529)	
weight	approx. 10g	

NPN TYPE  
CIRCUIT DIAGRAM

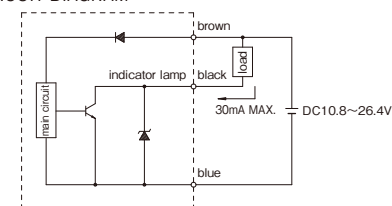

PNP TYPE  
CIRCUIT DIAGRAM

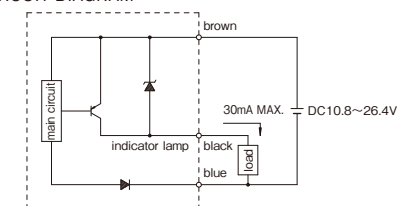

Please read the specifications and precautions of the manufacturer's catalog.

BELLOWS

BG type can be specified with a cover or bellows for dust prevention. Bellows are securely fixed for various installation methods in positioning and directions. Sensor for bellows is limited to K (proximity sensor) type only, which is pre-installed at proper positions. Please pay attention to the stroke limit of BG with bellows that is shorter than the standard stroke limit.

– Position of Sensor Cable Outlet –

The positions of the outlet for sensor cables can be selected as Figure H-16 shows.

Figure H-16 Position of Sensor Cable Outlet

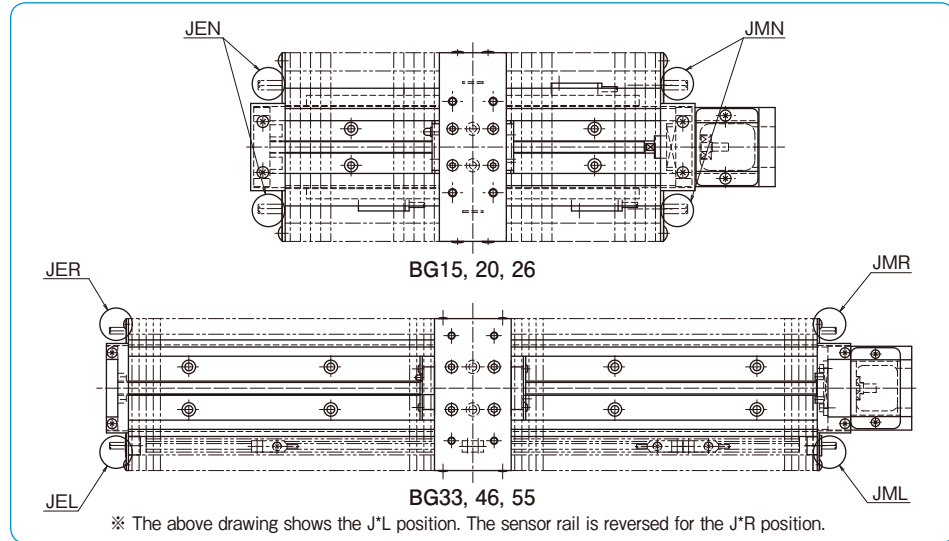

part number structure for bellows

1. J (for the first symbol)
2. Specification of the position of the sensor cable outlet  
Please select the motor side or the housing side.  
M: motor side E: housing side (end plate side)
3. Specification of the position of the sensor rail  
Please select the right hand or the left hand.  
R: on the right from the motor side  
L: on the left from the motor side  
※N for BG15, 20, and 26 since the sensors are mounted on both the right and left hand.
4. JNN for without sensors
5. Sensor type is K (proximity sensor) type only (APM-D3 series: YAMATAKE CORPORATION).

– Sensor Timing Chart –

The following chart shows the standard sensor arrangement.

Figure H-17 Sensor Timing Chart

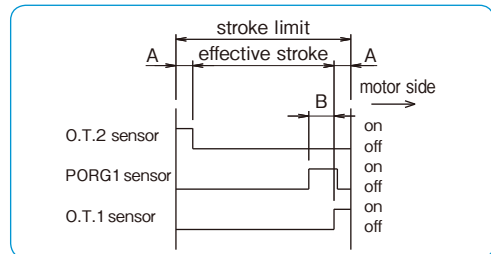

part number	A	B
<b>BG15</b>	5	8
<b>BG20</b>	5	8
<b>BG26</b>	5	13
<b>BG33</b>	10	13
<b>BG46</b>	10	13
<b>BG55</b>	10	13

BG15A, B

– 1 long block –

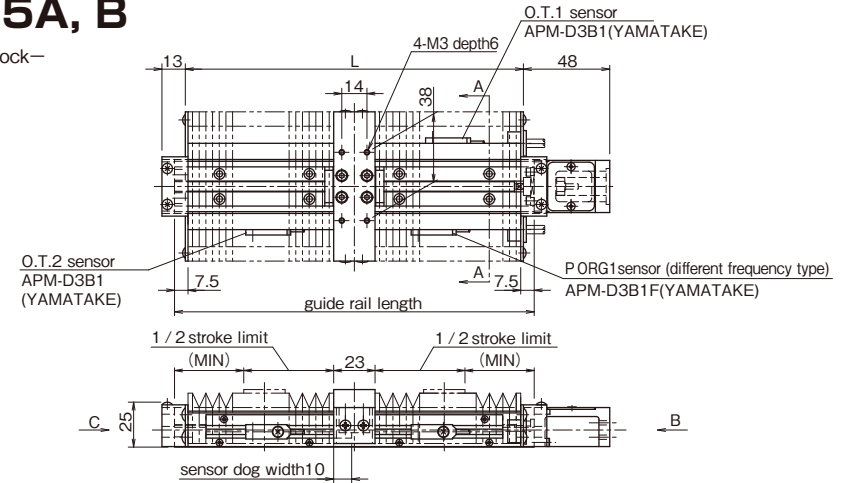

– 2 long blocks (in close contact) –

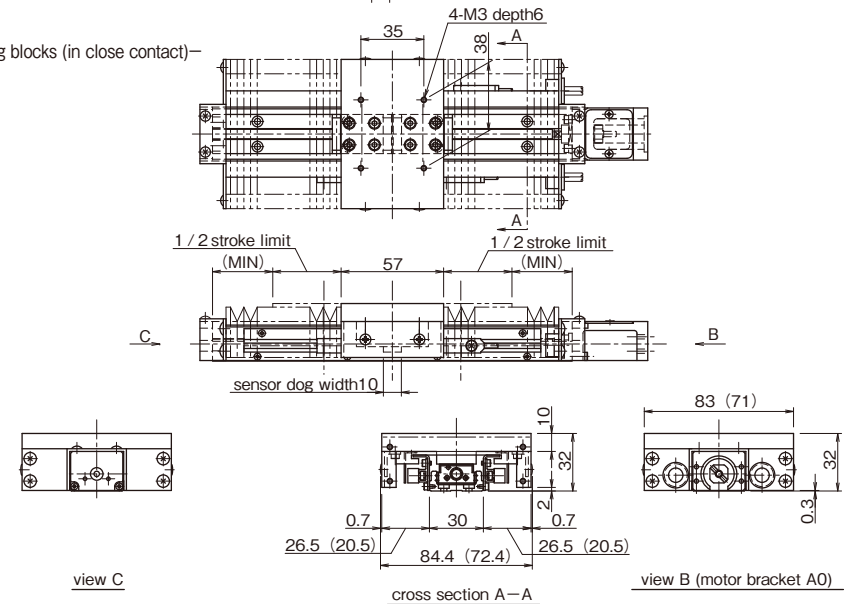

1. The drawings show the "JMN" configuration.
2. The numbers in the parentheses are the dimensions when sensors are not selected.
3. Please refer to page H-62 for dimensions that are not shown on the drawings.
4. material of bellows: composite resin sheet (shining black)

rail length	L	1 long block			2 long blocks		
		stroke limit	effective stroke	MIN	stroke limit	effective stroke	MIN
75	—	—	—	—	—	—	—
100	—	—	—	—	—	—	—
120	113	43	33	29.5	—	—	—
150*	138	60	50	33.5	40	30	26.5
175	163	85	75	33.5	59	49	29.5
200	188	100	90	38.5	76	60	33.5

※ The rail mounting holes at the center cannot be used for the rail length 150 with two long blocks.

### BG20A, B

—1 long block—

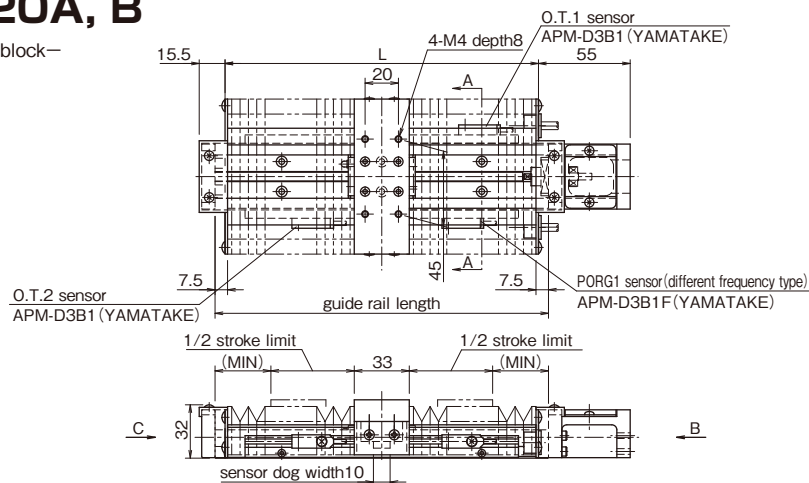

—2 long blocks (in close contact)—

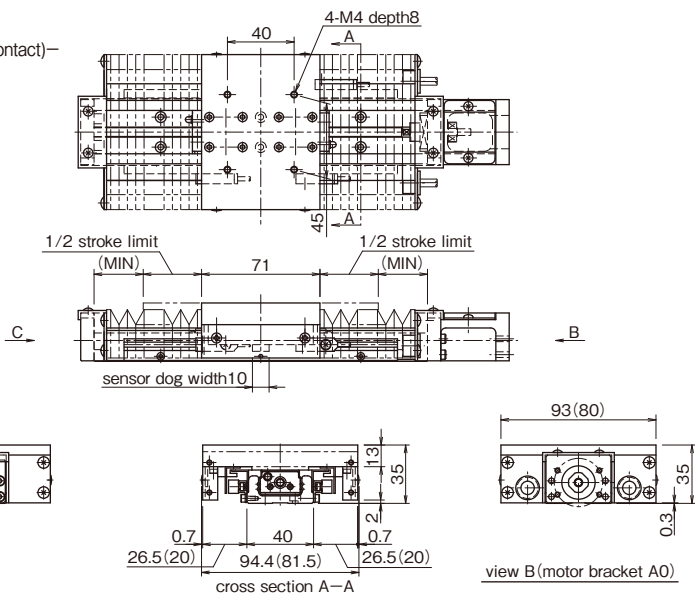

1. The drawings show the "JMN" configuration.
2. The numbers in the parentheses are the dimensions when sensors are not selected.
3. Please refer to page H-64 for dimensions that are not shown on the drawings.
4. material of bellows: composite resin sheet (shining black)

rail length	L	1 long block			2 long blocks		
		stroke limit	effective stroke	MIN	stroke limit	effective stroke	MIN
100	—	—	—	—	—	—	—
150*	138	58	48	29.5	32	22	23.5
200	188	100	90	33.5	70	60	29.5

\*The rail mounting holes at the center cannot be used for the rail length 150 with two long blocks.

### BG26A, B

—1 long block—

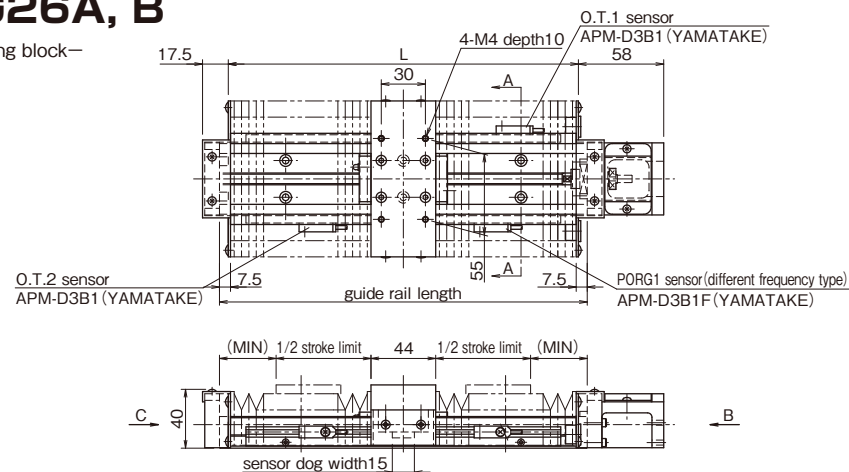

—2 long blocks (in close contact)—

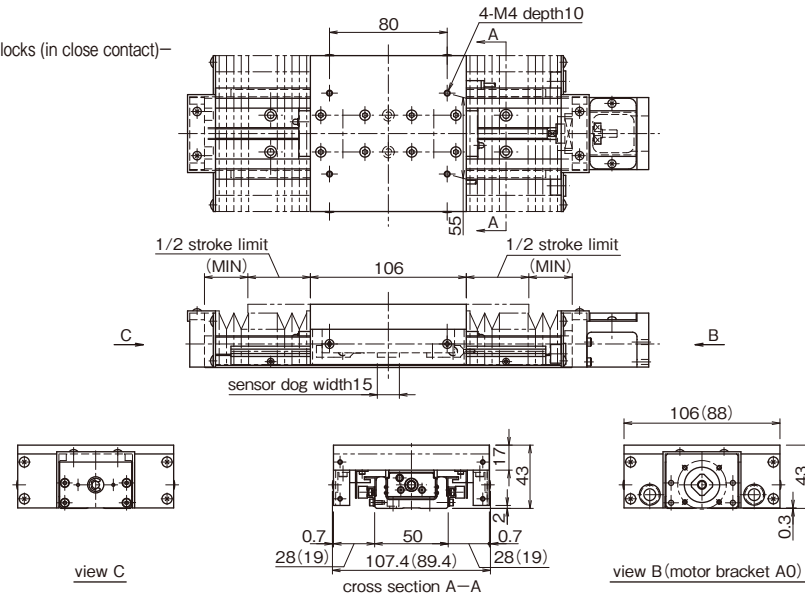

1. The drawings show the "JMN" configuration.
2. The numbers in the parentheses are the dimensions when sensors are not selected.
3. Please refer to page H-66 for dimensions that are not shown on the drawings.
4. material of bellows: composite resin sheet (shining black)

rail length	L	1 long block			2 long blocks		
		stroke limit	effective stroke	MIN	stroke limit	effective stroke	MIN
150	138	53	43	26.5	—	—	—
200*	188	97	87	29.5	41	31	26.5
250	238	129	119	38.5	85	75	29.5
300	288	169	159	43.5	127	117	33.5

\*The rail mounting holes at the center cannot be used for the rail length 200 with two long blocks.

### BG33A, B

—1 long block—

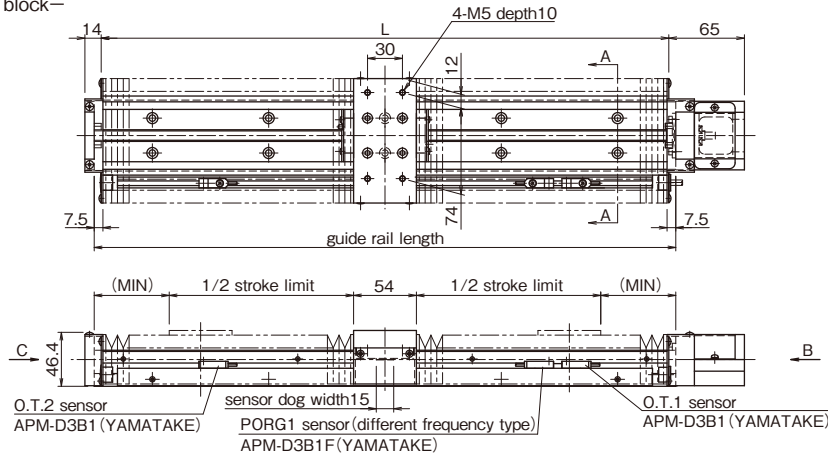

—2 long blocks (in close contact)—

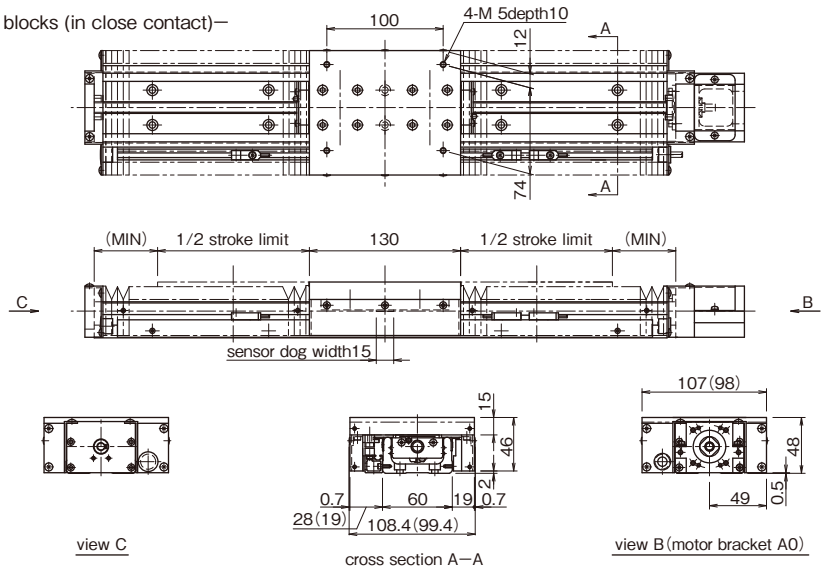

- The drawings show the "JML" configuration. The cross sections become reversed when "J\*R" is selected.
- The numbers in the parentheses are the dimensions when sensors are not selected.
- Please refer to page H-68 for dimensions that are not shown on the drawings.
- material of bellows: composite resin sheet (shining black)

rail length	L	1 long block			2 long blocks		
		stroke limit	effective stroke	MIN	stroke limit	effective stroke	MIN
150	—	—	—	—	—	—	—
200	188	79	59	33.5	—	—	—
300*	288	159	139	43.5	103	83	33.5
400	388	237	217	54.5	183	163	43.5
500	488	317	297	64.5	261	241	54.5
600	588	395	375	75.5	341	321	64.5

\*The rail mounting holes at the center cannot be used for the rail length 300 with two long blocks.

### BG33C, D

—1 short block—

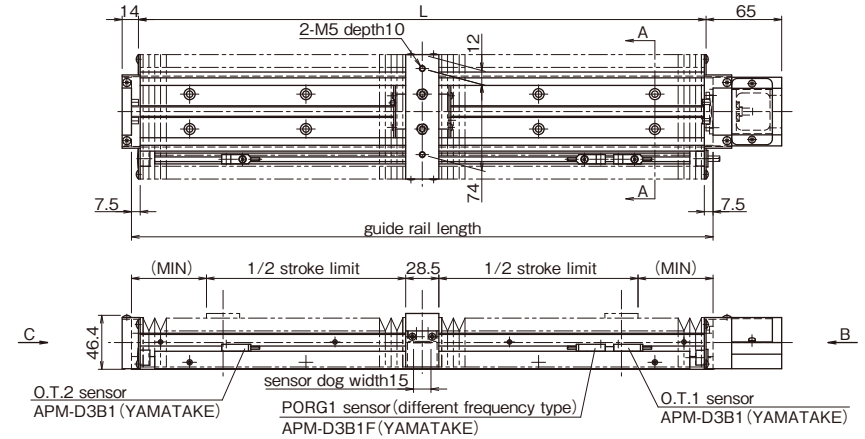

—2 short blocks (in close contact)—

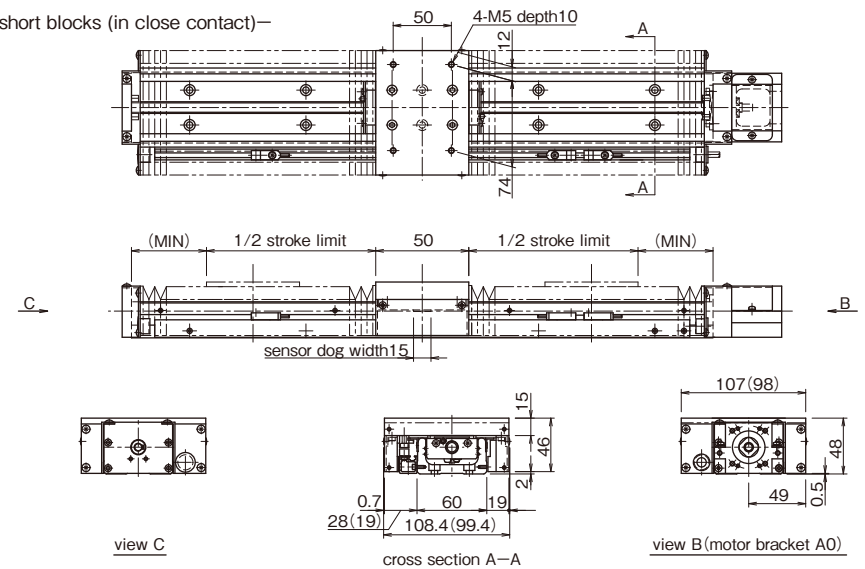

- The drawings show the "JML" configuration. The cross sections become reversed when "J\*R" is selected.
- The numbers in the parentheses are the dimensions when sensors are not selected.
- Please refer to page H-70 for dimensions that are not shown on the drawings.
- material of bellows: composite resin sheet (shining black)

rail length	L	1 short block			2 short blocks		
		stroke limit	effective stroke	MIN	stroke limit	effective stroke	MIN
150	138	68.5	48.5	26.5	—	—	—
200	188	104.5	84.5	33.5	67	47	26.5
300	288	184.5	164.5	43.5	143	123	38.5
400	388	262.5	242.5	54.5	211	191	54.5
500	488	342.5	322.5	64.5	291	271	64.5
600	588	404.5	384.5	83.5	369	349	75.5

# BG46A, B

-1 long block-

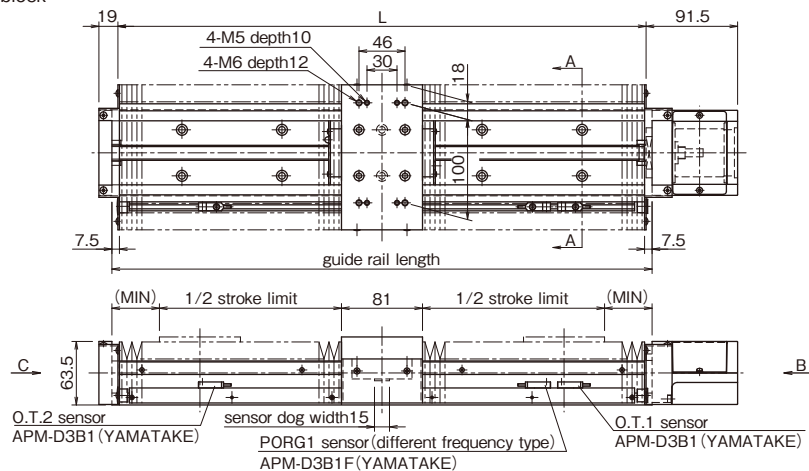

-2 long blocks (in close contact)-

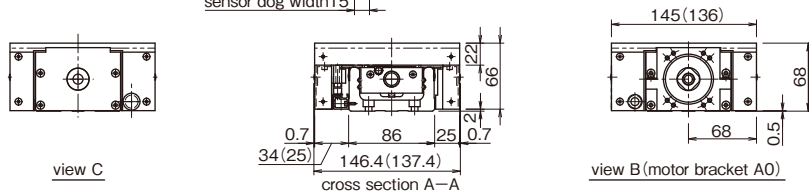
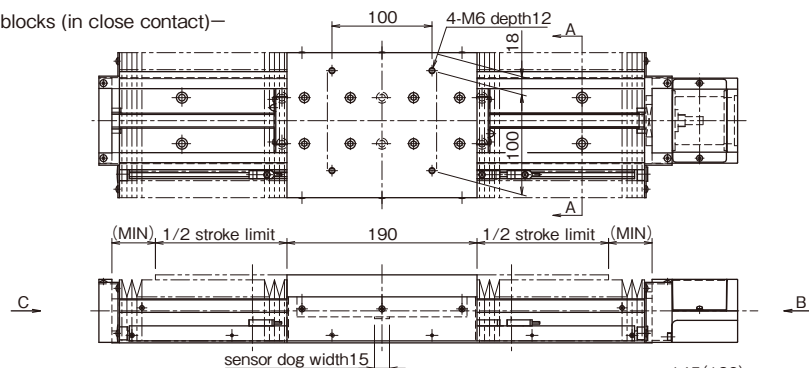

- The drawings show the "JML" configuration. The cross sections become reversed when "J+R" is selected.
- The numbers in the parentheses are the dimensions when sensors are not selected.
- Please refer to page H-72 for dimensions that are not shown on the drawings.
- material of bellows: composite resin sheet (shining black)

rail length	L	1 long block			2 long blocks		
		stroke limit	effective stroke	MIN	stroke limit	effective stroke	MIN
340*	328	192	172	33.5	97	77	26.5
440	428	272	252	43.5	183	163	33.5
540	528	364	344	47.5	263	243	43.5
640	628	450	430	54.5	355	335	47.5
740	728	530	510	64.5	441	421	54.5
840	828	608	588	75.5	521	501	64.5
940	928	686	666	86.5	599	579	75.5
1,040	1,028	774	754	92.5	677	657	86.5
1,140	1,128	866	846	96.5	765	745	92.5
1,240	1,228	944	924	107.5	857	837	96.5

\*The rail mounting holes at the center cannot be used for the rail length 340 with two short or long blocks.

# BG46C, D

-1 short block-

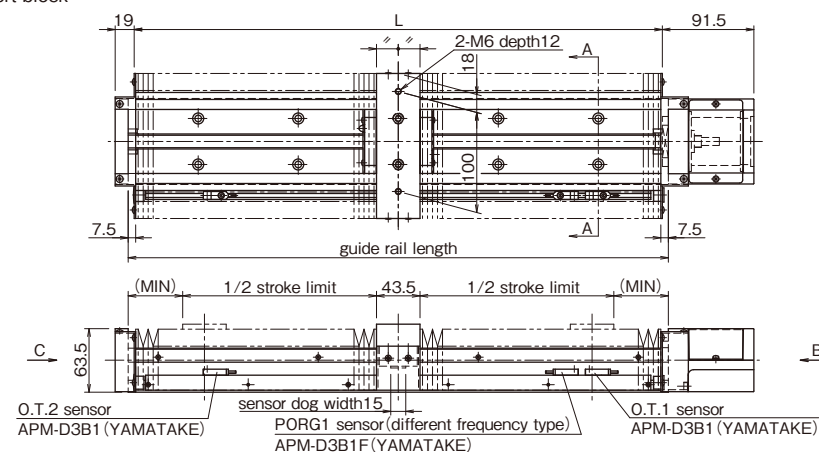

-2 short blocks (in close contact)-

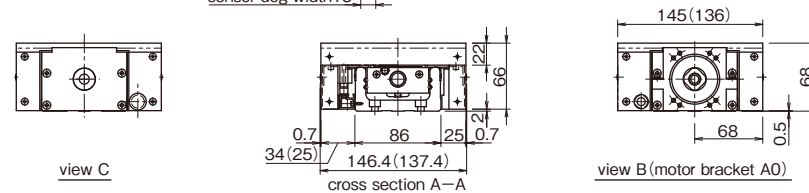
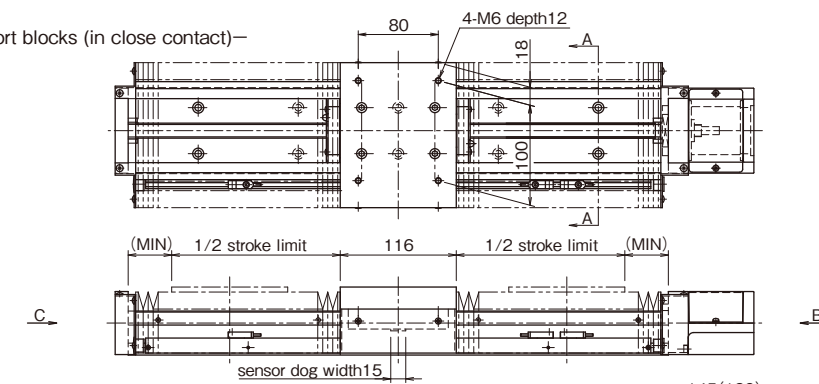

- The drawings show the "JML" configuration. The cross sections become reversed when "J+R" is selected.
- The numbers in the parentheses are the dimensions when sensors are not selected.
- Please refer to page H-74 for dimensions that are not shown on the drawings.
- material of bellows: composite resin sheet (shining black)

rail length	L	1 short block			2 short blocks		
		stroke limit	effective stroke	MIN	stroke limit	effective stroke	MIN
340*	328	219.5	199.5	38.5	165	145	29.5
440	428	309.5	289.5	43.5	247	227	38.5
540	528	387.5	367.5	54.5	337	317	43.5
640	628	467.5	447.5	64.5	415	395	54.5
740	728	545.5	525.5	75.5	495	475	64.5
840	828	645.5	625.5	75.5	573	553	75.5
940	928	723.5	703.5	86.5	651	631	86.5
1,040	1,028	803.5	783.5	96.5	731	711	86.5
1,140	1,128	881.5	861.5	107.5	811	791	96.5
1,240	1,228	961.5	941.5	107.5	899	879	96.5

\*The rail mounting holes at the center cannot be used for the rail length 340 with two short or long blocks.

# BG55A, B

—1 long block—

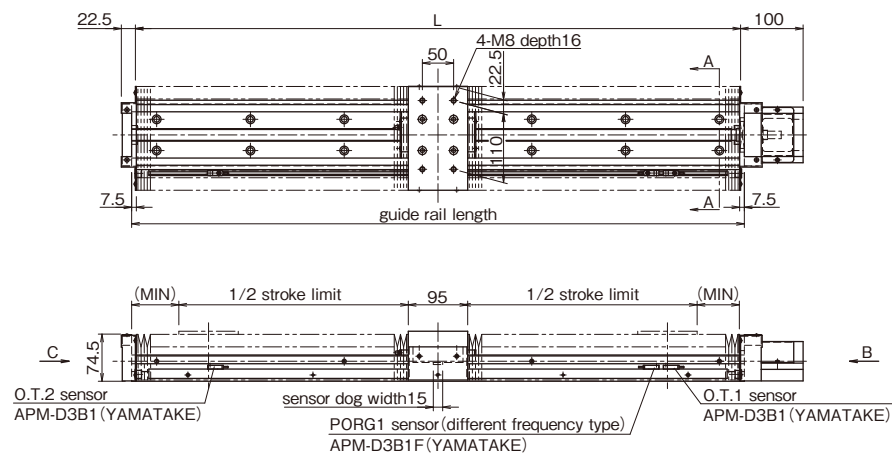

—2 long blocks (in close contact)—

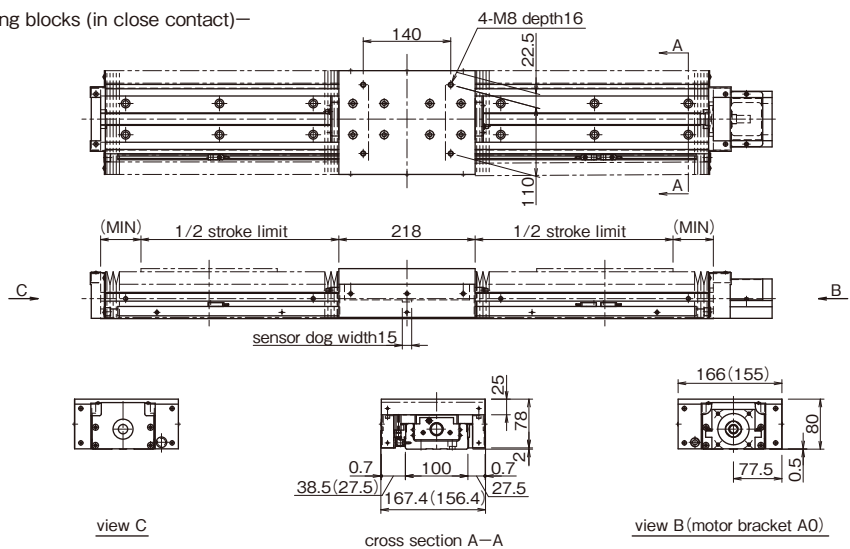

- The drawings show the "JML" configuration. The cross sections become reversed when "J\*R" is selected.
- The numbers in the parentheses are the dimensions when sensors are not selected.
- Please refer to page H-76 for dimensions that are not shown on the drawings.
- material of bellows: composite resin sheet (shining black)

rail length	L	1 long block		2 long blocks			
		stroke limit	effective stroke	MIN	stroke limit	effective stroke	MIN
980	968	734	714	75.5	633	613	64.5
1,080	1,068	812	792	86.5	711	691	75.5
1,180	1,168	912	892	86.5	789	769	86.5
1,280	1,268	992	972	96.5	889	869	86.5
1,380	1,368	1,070	1,050	107.5	969	949	96.5

## POSITIONING PIN HOLE

For the BG type, positioning pin holes can be provided on the slide block and sub table by adding the option code "PS" or "PW" in the end of the part number.

The option code "PR" is used to provide the guide rail with positioning pin holes.

When positioning pin holes are necessary on both the slide block/sub table and guide rail, please add the option code "PSR" or "PWR" as shown in Table H-17.

Table H-17 Option Code for Positioning Pin Hole

pin hole		slide block		
		PS	PW	none
guide rail	PR	PSR	PWR	PR
	none	PS	PW	none

### Positioning Pin Hole for Slide Block and Sub Table

It is useful when exacting reassembly positioning is required. In case of two blocks used, both blocks are processed.

When the code "PS" is added, the drilling is processed only on the mounting surface (slide block or sub table). When the code "PW" is specified for a BG with a top cover (except for BG15), the slide block and sub table are connected by the straight pins at the location where the "PS" option specifies on the slide block.

Note that NB does not supply straight pins for the "PS" option.

# BG15A, B

(PS Option)  
—With Top Cover—

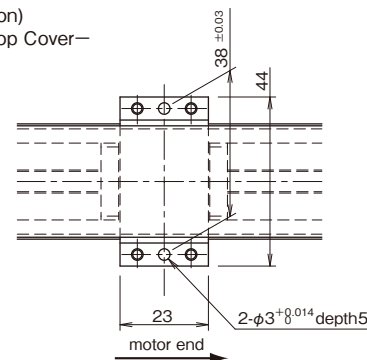

※Please contact NB for the without-top-cover option or the "PW" option.

### BG20A, B

(PS Option)  
 -Without Top Cover-

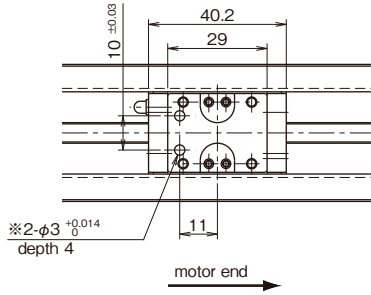

-With Top Cover-

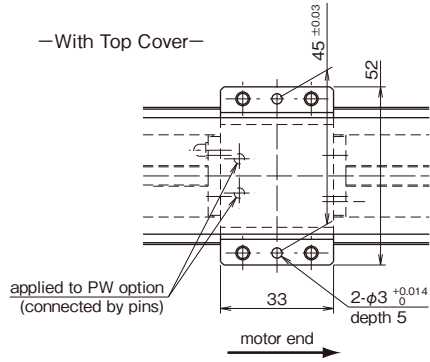

※For some cases, a shallow counterbore of φ4 will be machined at the hole area with "※" to remove a hardened layer.

### BG26A, B

(PS Option)  
 -Without Top Cover-

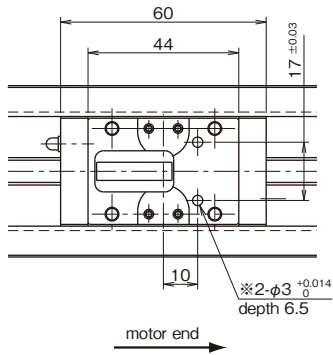

-With Top Cover-

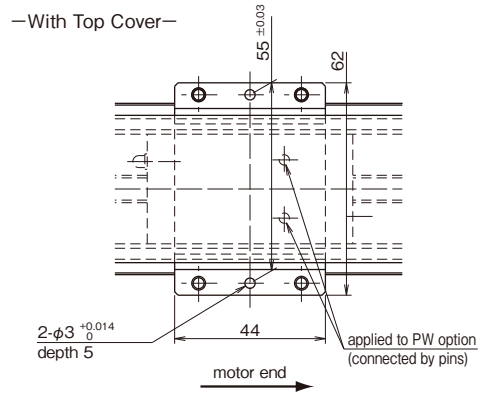

※For some cases, a shallow counterbore of φ4 will be machined at the hole area with "※" to remove a hardened layer.

### BG33A, B

(PS Option)  
 -Without Top Cover-

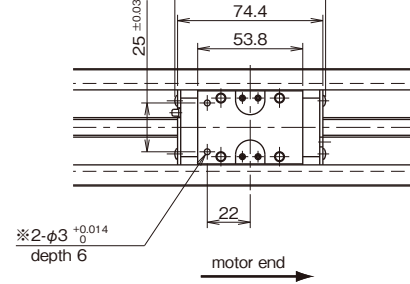

-With Top Cover-

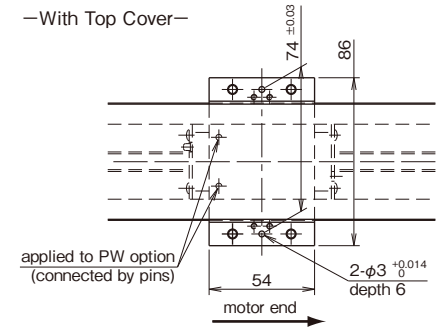

※For some cases, a shallow counterbore of φ4 will be machined at the hole area with "※" to remove a hardened layer.

### BG33C, D

(PS Option)  
 -Without Top Cover-

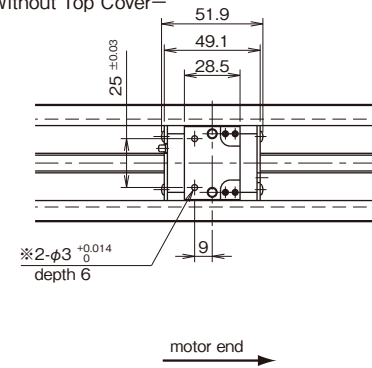

-With Top Cover-

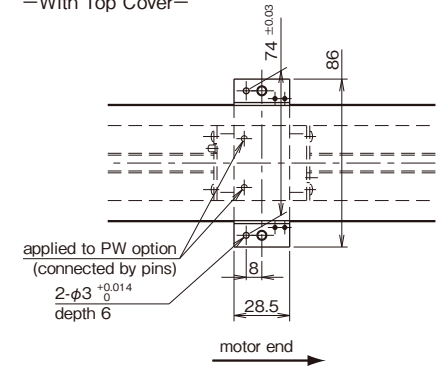

※For some cases, a shallow counterbore of φ4 will be machined at the hole area with "※" to remove a hardened layer.

### BG46A, B

(PS Option)

—Without Top Cover—

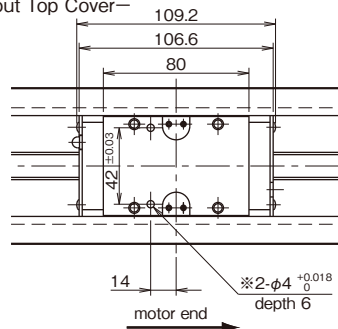

—With Top Cover—

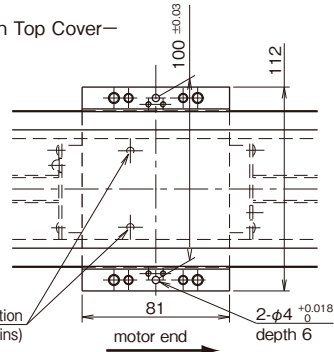

※For some cases, a shallow counterbore of  $\phi 5$  will be machined at the hole area with "※" to remove a hardened layer.

### BG46C, D

(PS Option)

—Without Top Cover—

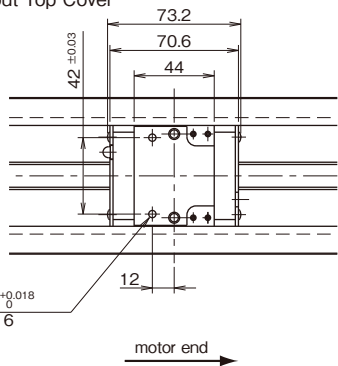

—With Top Cover—

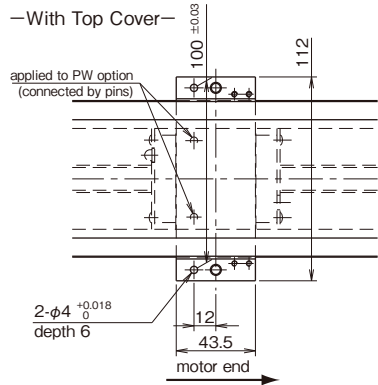

※For some cases, a shallow counterbore of  $\phi 5$  will be machined at the hole area with "※" to remove a hardened layer.

### BG55A, B

(PS Option)

—Without Top Cover—

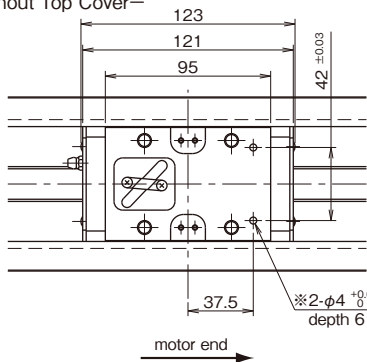

—With Top Cover—

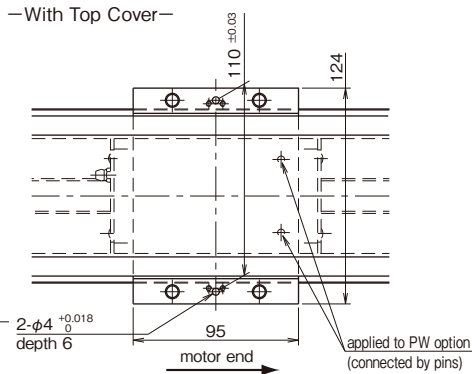

※For some cases, a shallow counterbore of  $\phi 5$  will be machined at the hole area with "※" to remove a hardened layer.

### POSITIONING PIN HOLE FOR GUIDE RAIL

It is useful to use positioning pin holes on the guide rail when exacting reassembly positioning is required. After the insertion of the straight pins in the BG guide rail base, the pins might interfere with the slide block. In the positioning process, please consider the BG base thickness. The length of the pin in the BG base shall be shorter than the BG base thickness. Please make sure that the pins shall not interfere with the slide block. Table H-18 shows the pin length in the BG base. Note that NB does not supply straight pins for the guide rail. (Parallel pin type A is recommended.)

Figure H-18 Positioning Pin Hole Location

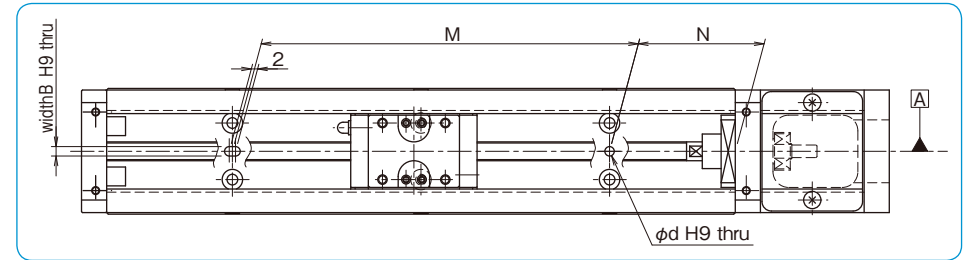
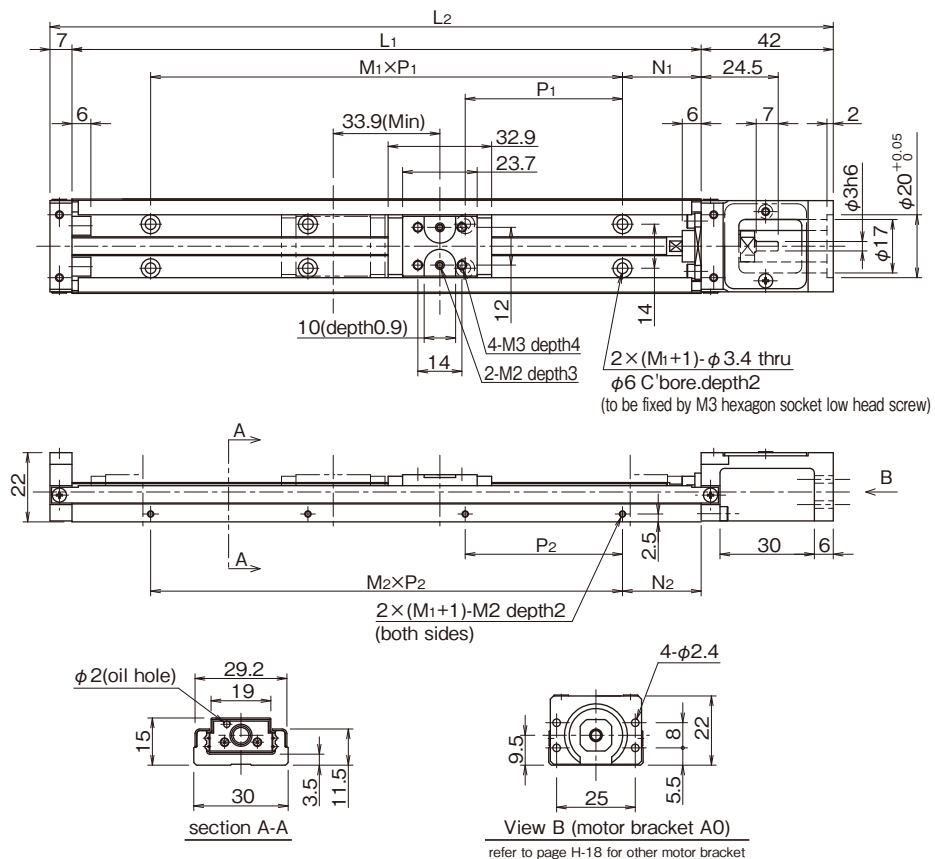

Table H-18 Positioning Pin Hole for Guide Rail

part number	pin length (BG base thickness)	major dimensions												
		rail length	N	M	$\phi d$	B								
BG15	3.5 or less	75	12.5	50	$\phi 3^{+0.025}$	$3^{+0.025}$								
		100	25											
		125	12.5	100										
		150	25											
		175	12.5											
BG20	4.5 or less	100	20	60			$\phi 3^{+0.025}$	$3^{+0.025}$						
		150	15											
		200	40	120										
BG26	6 or less	150	35						80	$\phi 3^{+0.025}$	$3^{+0.025}$			
		200	20											
		250	45	160										
BG33	8 or less	300	30		240	$\phi 3^{+0.025}$			$3^{+0.025}$					
		150	25									100		
		200	50	200										
		300			300									
		400					400							
500	500													
600		500												
BG46			11 or less	340				70		200	$\phi 5^{+0.030}$	$5^{+0.030}$		
				440	300									
				540			400							
	640			500										
	740	600												
	840					700								
	940								800					
	1,040												900	
	1,140													1,000
	1,240													
BG55	13 or less		980					40		900	$\phi 6^{+0.030}$	$6^{+0.030}$		
			1,080		15			1,050						
			1,180		65		1,200							
			1,280	40										
		1,380	15	1,350										

# BG15A, B

—Without Top Cover—



—With Top Cover—

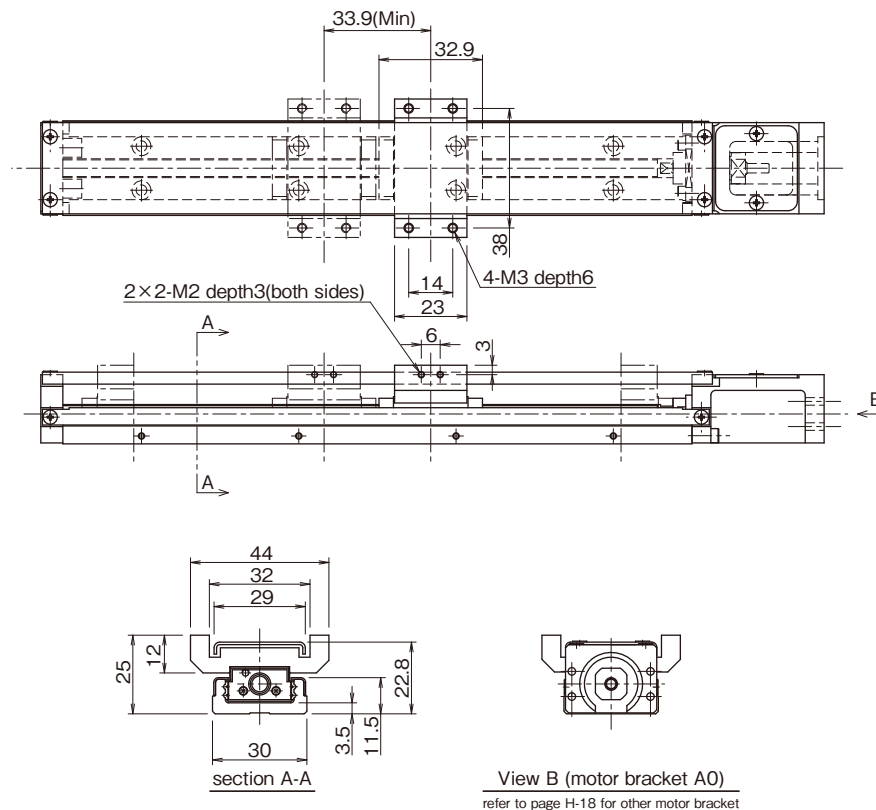

dimensions						stroke limit	
L1	L2	N1	M1×P1	N2	M2×P2	BG15A	BG15B
75	124	12.5	1×50	12.5	1×50	30	—
100	149	25		25		55	—
125	174	12.5	2×50	12.5	2×50	80	46
150	199	25		25		105	71
175	224	12.5	3×50	12.5	3×50	130	96
200	249	25		25		155	121

Stroke limit is a drive distance between both ends of the dampers.

# BG20A, B

—Without Top Cover—

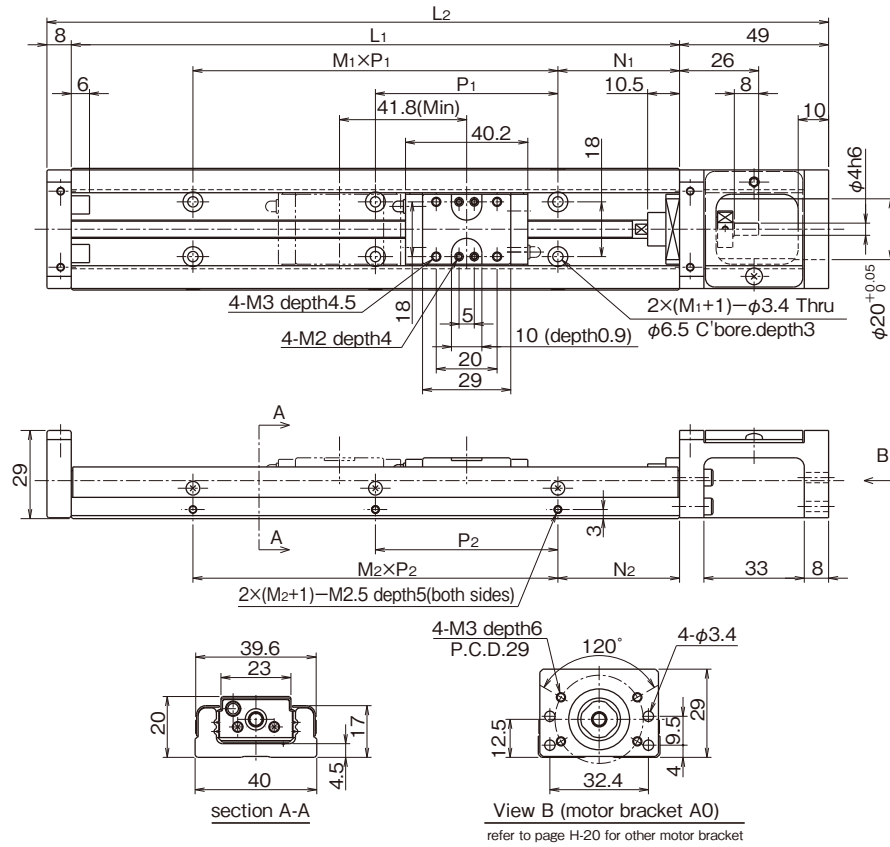

—With Top Cover—

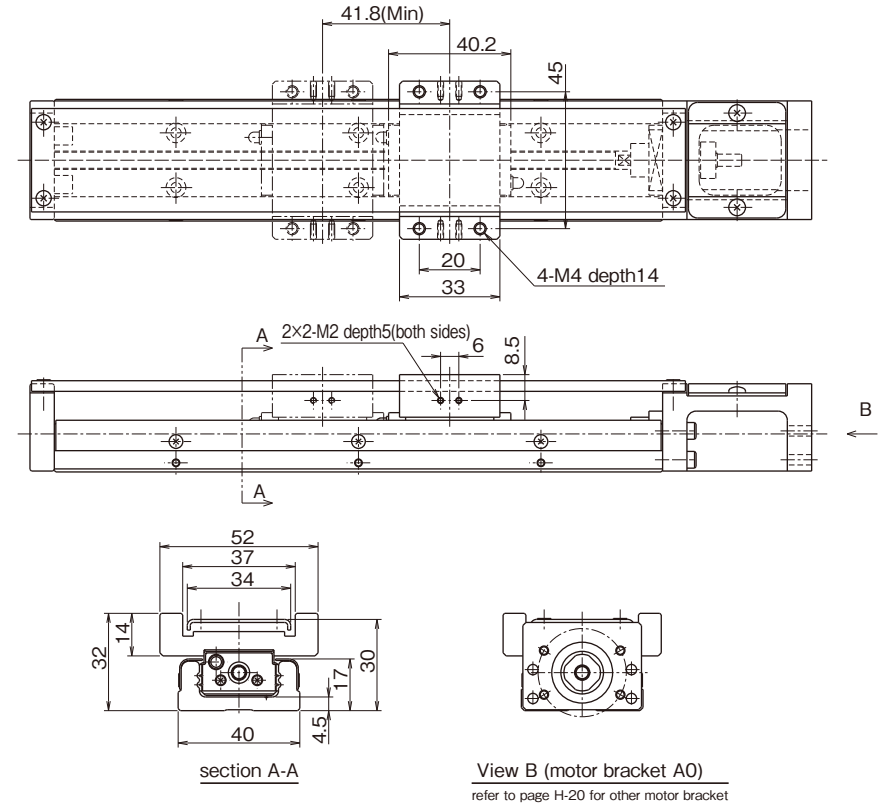

dimensions						stroke limit	
L1	L2	N1	M1×P1	N2	M2×P2	BG20A	BG20B
100	157	20	1×60	20	1×60	43	—
150	207	15	2×60	15	2×60	93	51
200	257	40		40		143	101

Stroke limit is a drive distance between both ends of the dampers.

# BG26A, B

—Without Top Cover—

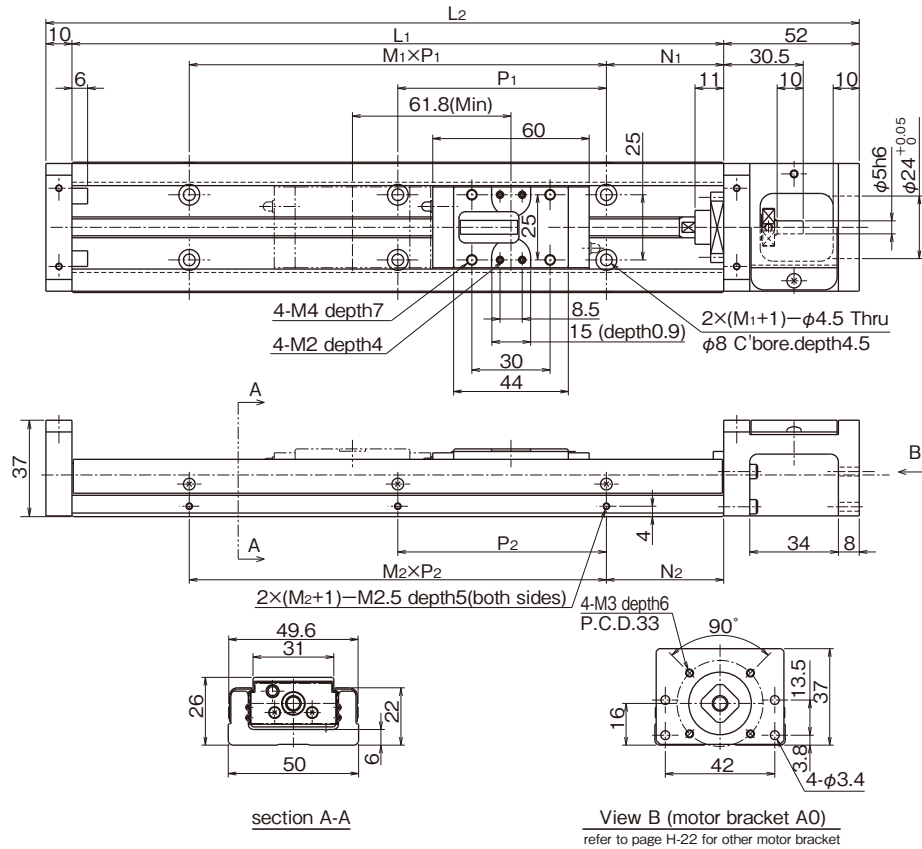

—With Top Cover—

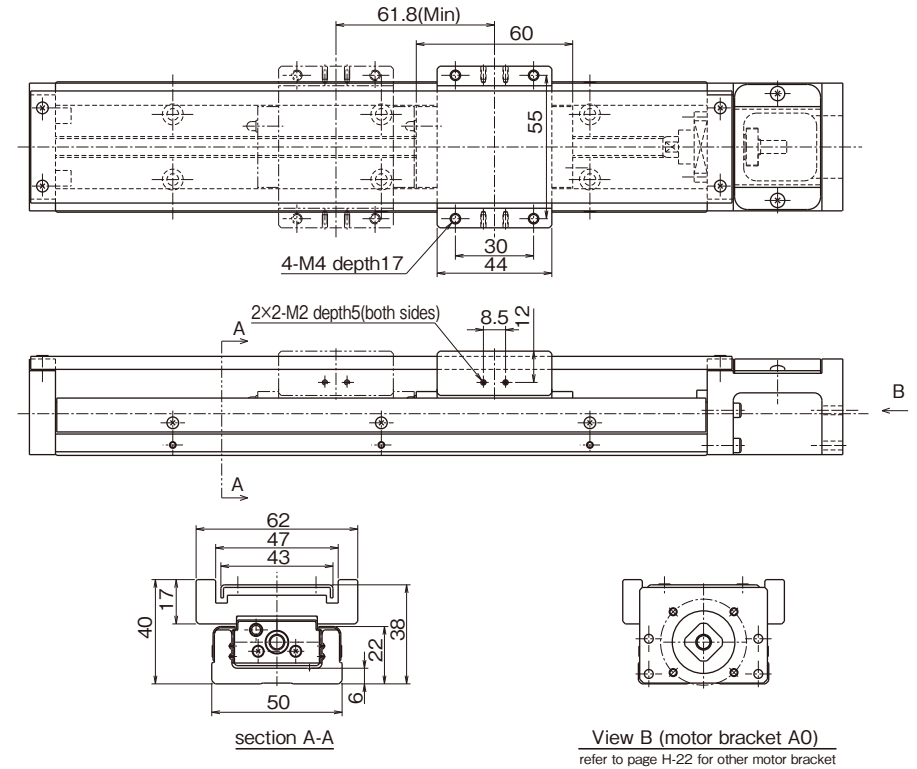

dimensions						stroke limit	
L <sub>1</sub>	L <sub>2</sub>	N <sub>1</sub>	M <sub>1</sub> ×P <sub>1</sub>	N <sub>2</sub>	M <sub>2</sub> ×P <sub>2</sub>	BG26A	BG26B
150	212	35	1×80	35	1×80	73	—
200	262	20	2×80	20	2×80	123	61
250	312	45		45		173	111
300	362	30	3×80	30	3×80	223	161

Stroke limit is a drive distance between both ends of the dampers.

# BG33A, B

—Without Top Cover—

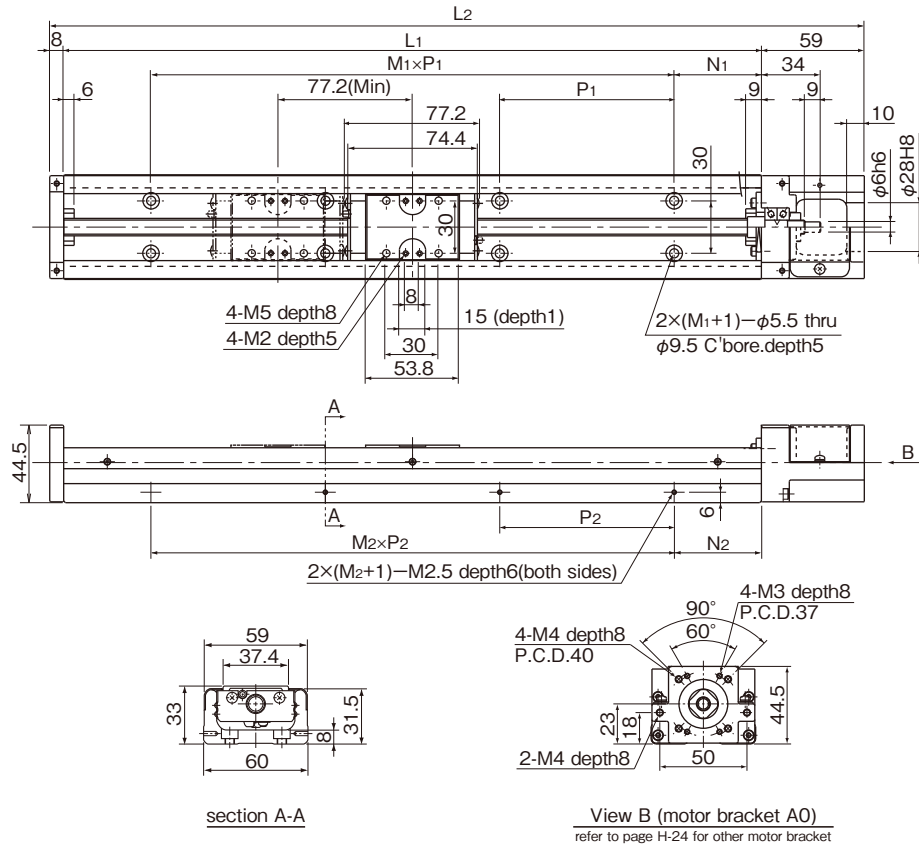

—With Top Cover—

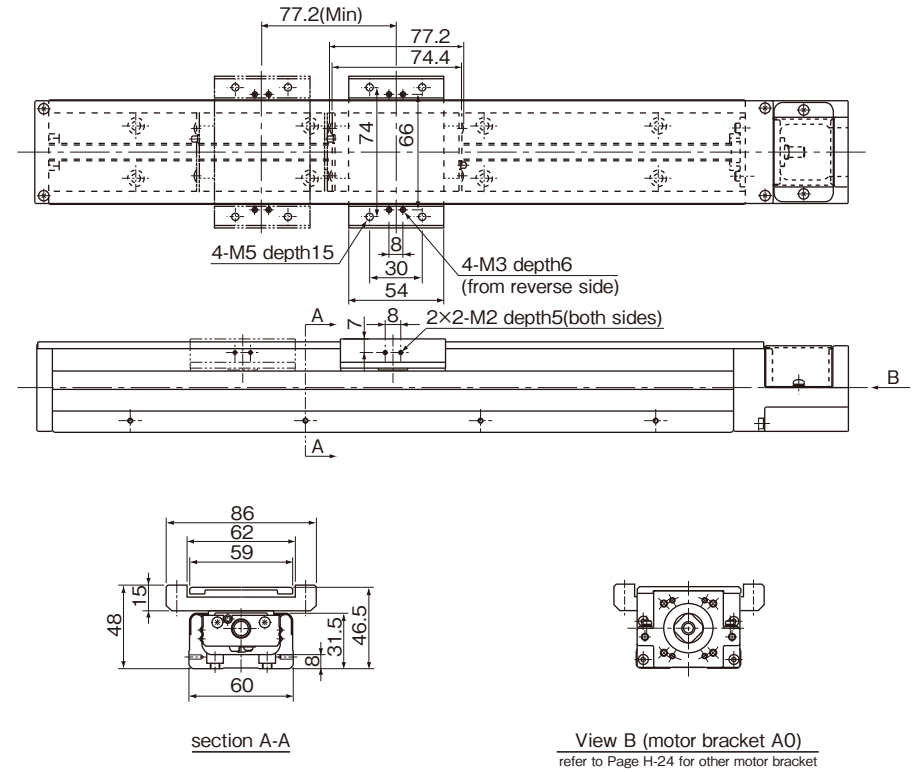

dimensions						stroke limit	
L1	L2	N1	M1×P1	N2	M2×P2	BG33A	BG33B
150	217	25	1×100	25	1×100	60	—
200	267		2×100		2×100	110	—
300	367		3×100		3×100	210	133
400	467	50	3×100	50	3×100	310	233
500	567		4×100		4×100	410	333
600	667		5×100		5×100	510	433

Stroke limit is a drive distance between both ends of the dampers.

# BG33C, D

—Without Top Cover—

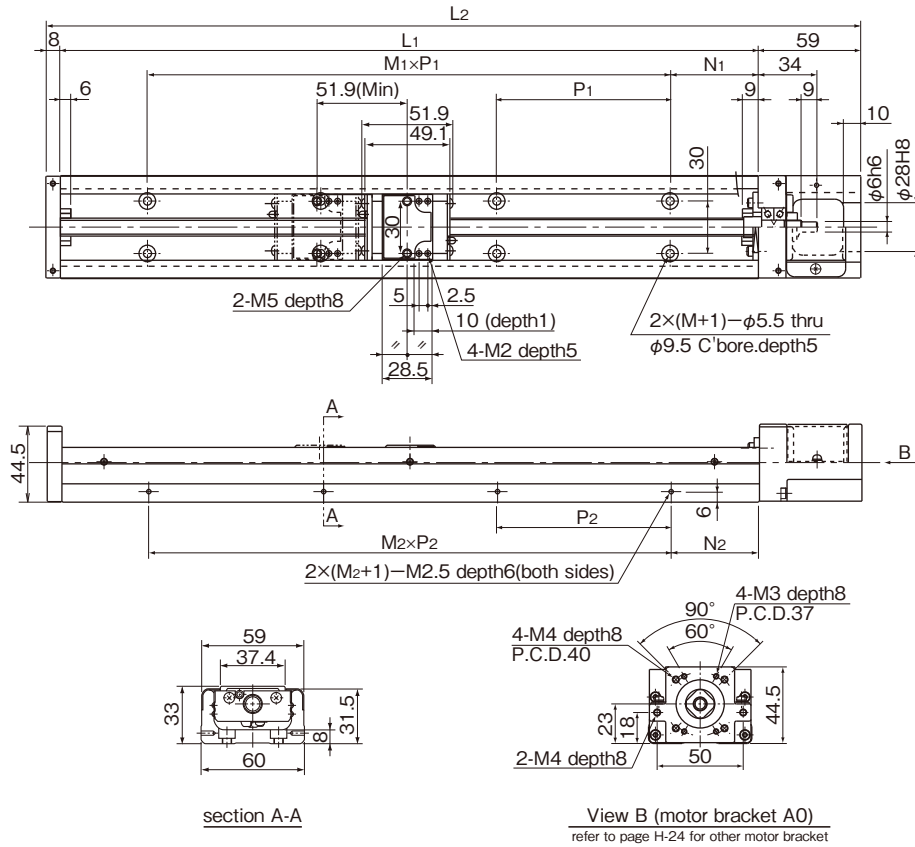

section A-A

View B (motor bracket A0)  
refer to page H-24 for other motor bracket

—With Top Cover—

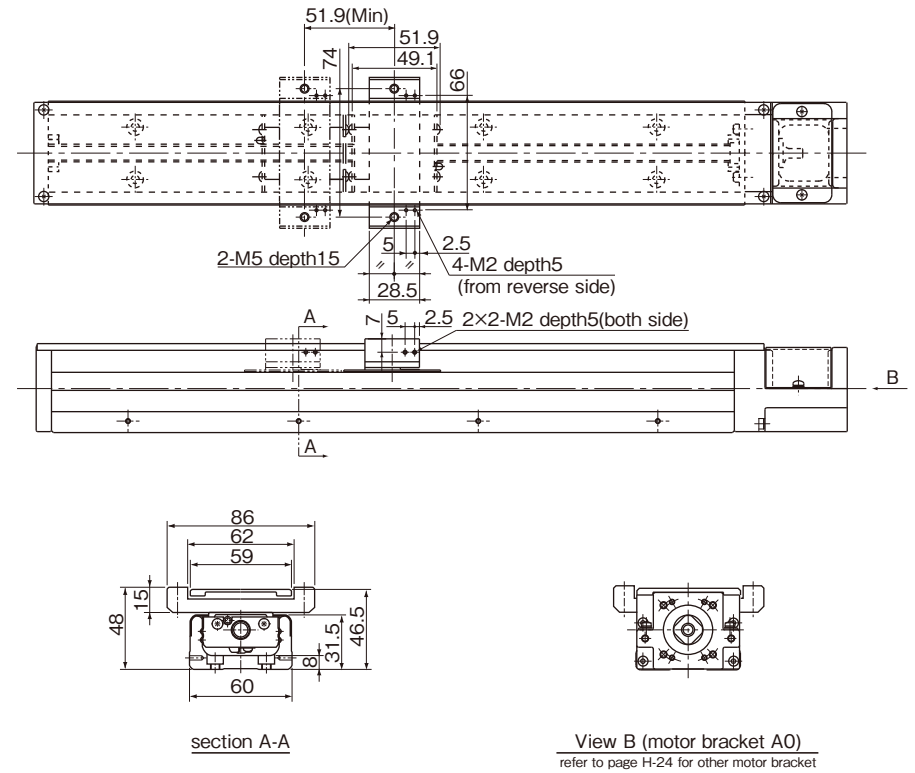

section A-A

View B (motor bracket A0)  
refer to page H-24 for other motor bracket

dimensions						stroke limit	
L1	L2	N1	M1×P1	N2	M2×P2	BG33C	BG33D
150	217	25	1×100	25	1×100	85	34
200	267		2×100		2×100	135	84
300	367		3×100		3×100	235	184
400	467	50	3×100	50	3×100	335	284
500	567		4×100		4×100	435	384
600	667		5×100		5×100	535	484

Stroke limit is a drive distance between both ends of the dampers.

# BG46A, B

—Without Top Cover—

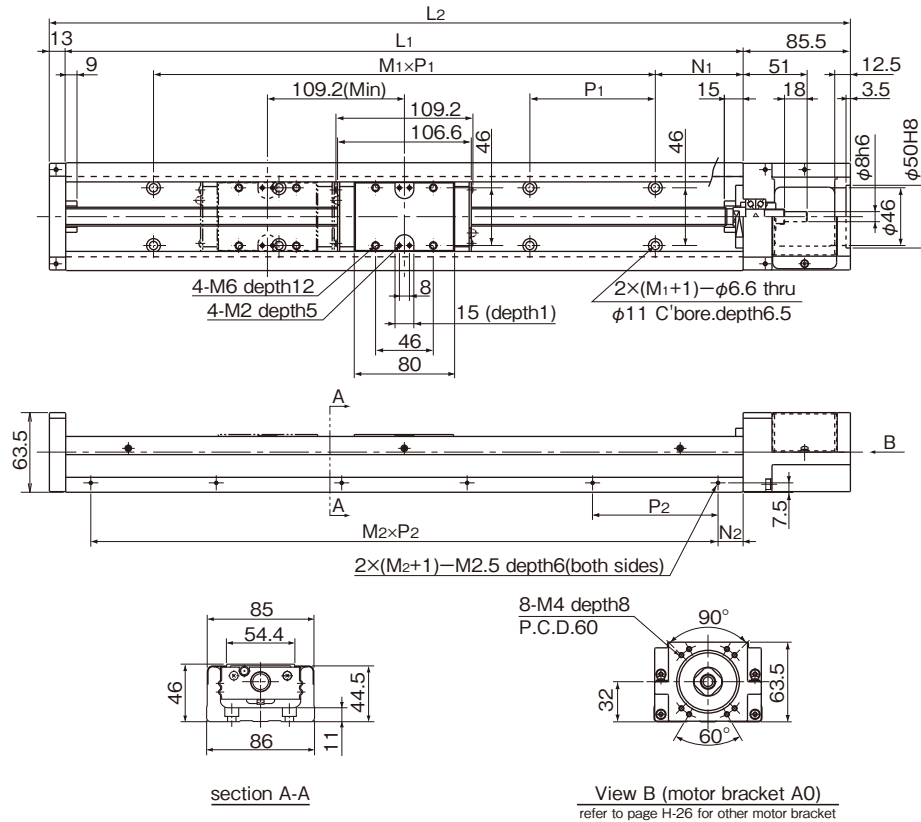

—With Top Cover—

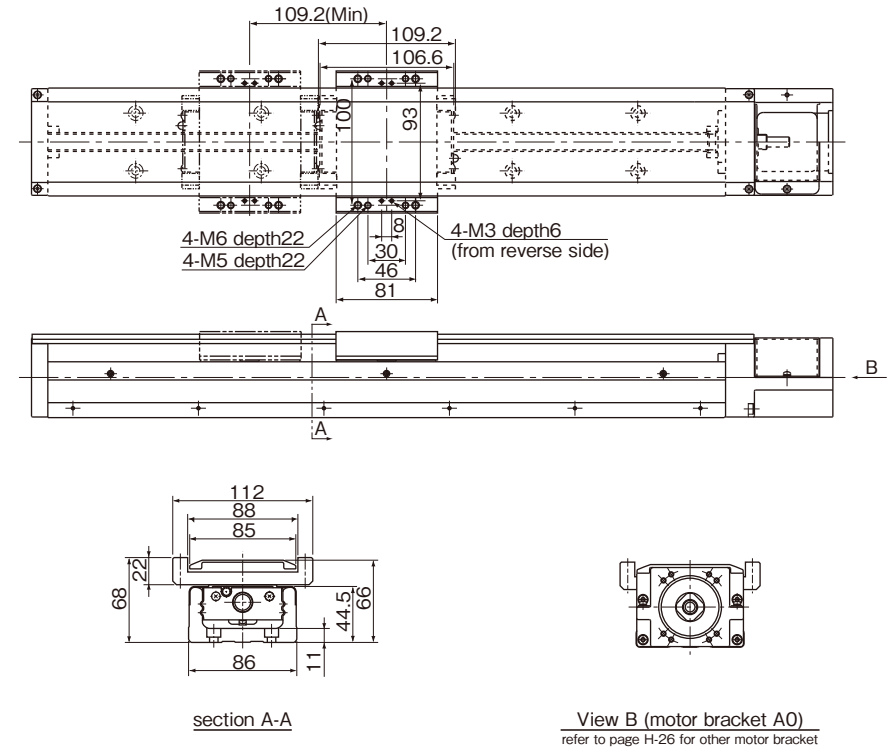

dimensions					stroke limit		
L1	L2	N1	M1×P1	N2	M2×P2	BG46A	BG46B
340	438.5	70	2×100	20	3×100	209	100
440	538.5		3×100		4×100	309	200
540	638.5		4×100		5×100	409	300
640	738.5		5×100		6×100	509	400
740	838.5		6×100		7×100	609	500
840	938.5		7×100		8×100	709	600
940	1,038.5		8×100		9×100	809	700
1,040	1,138.5		9×100		10×100	909	800
1,140	1,238.5		10×100		11×100	1,009	900
1,240	1,338.5		11×100		12×100	1,109	1,000

Stroke limit is a drive distance between both ends of the dampers.

# BG46C, D

—Without Top Cover—

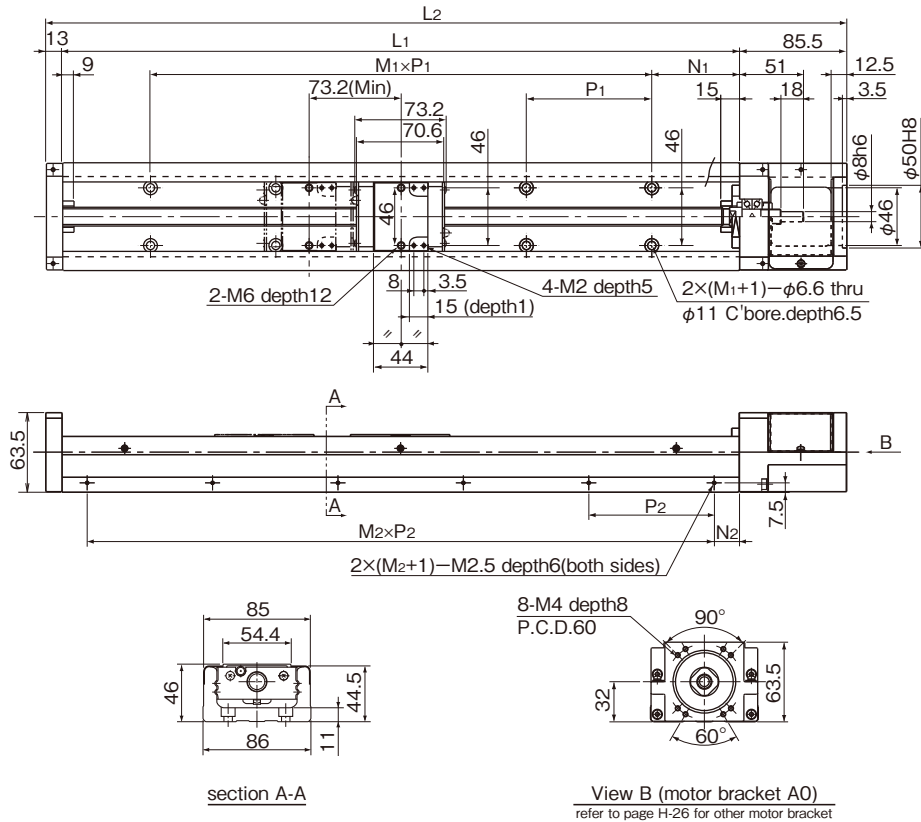

section A-A

View B (motor bracket A0)  
refer to page H-26 for other motor bracket

—With Top Cover—

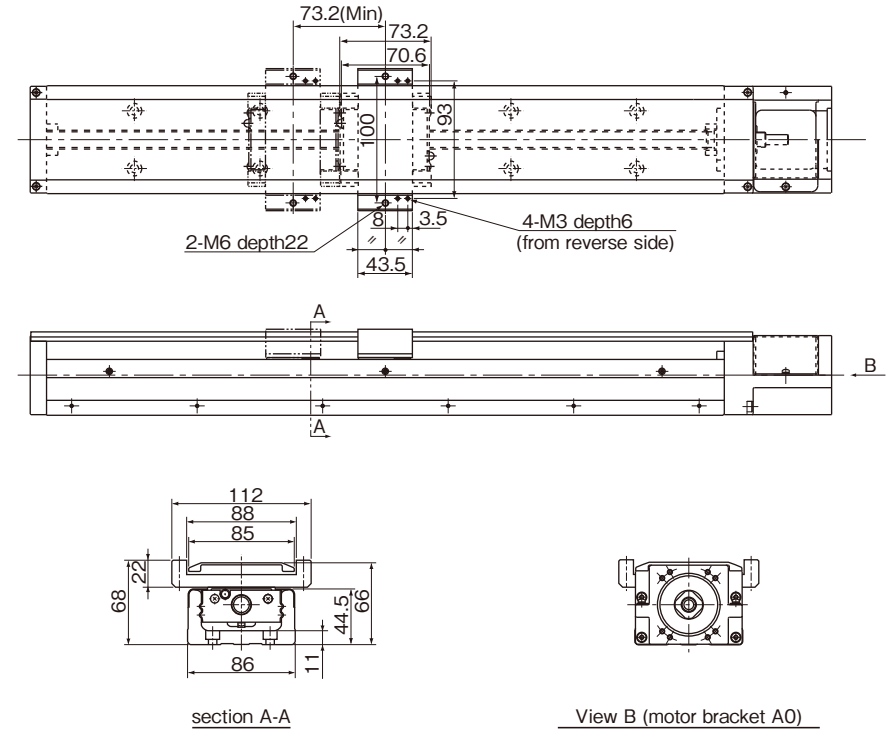

section A-A

View B (motor bracket A0)  
refer to page H-26 for other motor bracket

dimensions					stroke limit		
L1	L2	N1	M1×P1	N2	M2×P2	BG46C	BG46D
340	438.5	70	2×100	20	3×100	245	172
440	538.5		3×100		4×100	345	272
540	638.5		4×100		5×100	445	372
640	738.5		5×100		6×100	545	472
740	838.5		6×100		7×100	645	572
840	938.5		7×100		8×100	745	672
940	1,038.5		8×100		9×100	845	772
1,040	1,138.5		9×100		10×100	945	872
1,140	1,238.5		10×100		11×100	1,045	972
1,240	1,338.5		11×100		12×100	1,145	1,072

Stroke limit is a drive distance between both ends of the dampers.

# BG55A, B

—Without Top Cover—

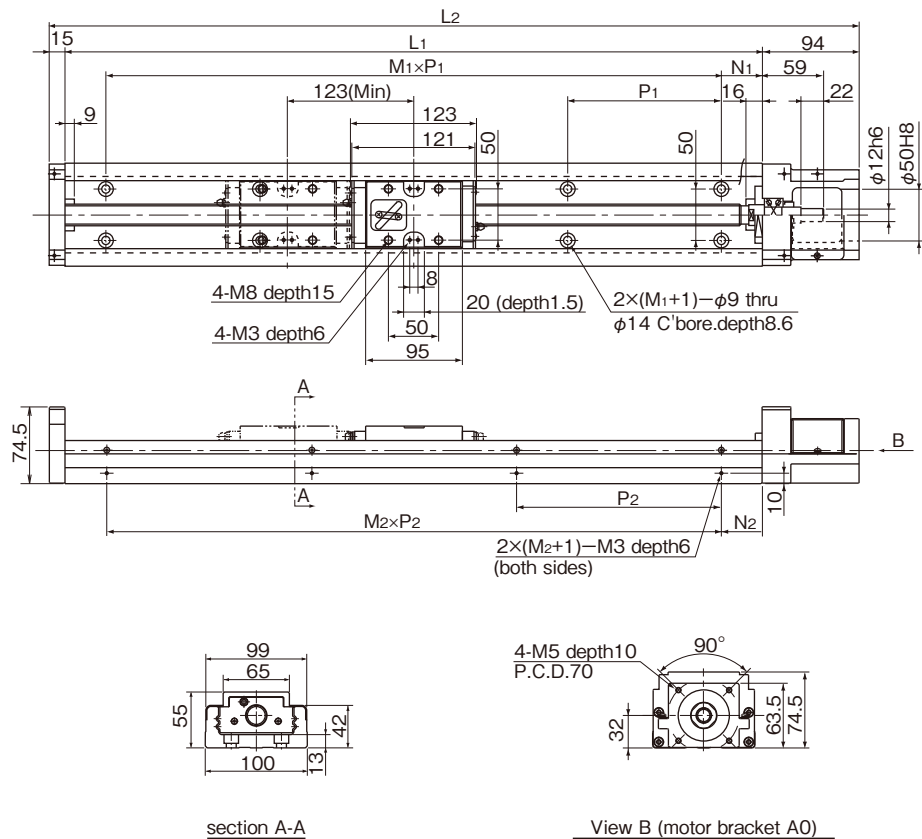

section A-A

View B (motor bracket A0)  
refer to page H-28 for other motor bracket

—With Top Cover—

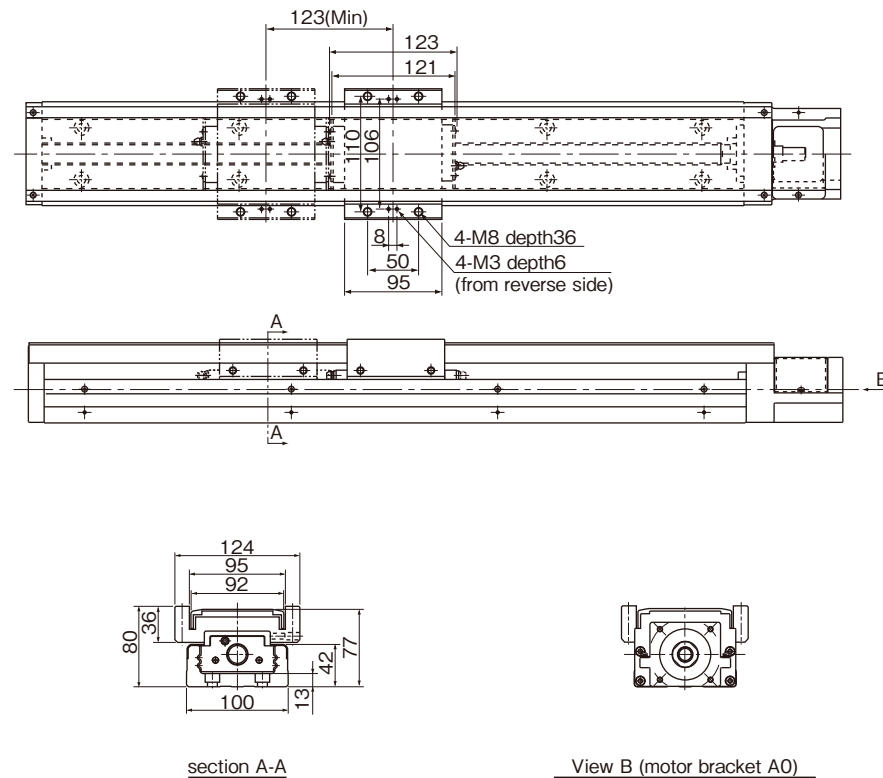

section A-A

View B (motor bracket A0)  
refer to page H-28 for other motor bracket

dimensions						stroke limit	
L1	L2	N1	M1×P1	N2	M2×P2	BG55A	BG55B
980	1,089	40	6×150	90	4×200	834	711
1,080	1,189	15	7×150	40	5×200	934	811
1,180	1,289	65		90		1,034	911
1,280	1,389	40	8×150	40	6×200	1,134	1,011
1,380	1,489	15	9×150	90		1,234	1,111

Stroke limit is a drive distance between both ends of the dampers.