

Támcsapágy választék

EK – motor oldali támcsapágy

EK05

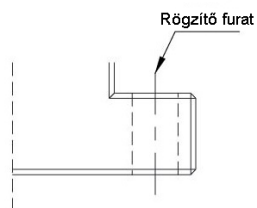

EK05 ~ 08

EK06, EK08

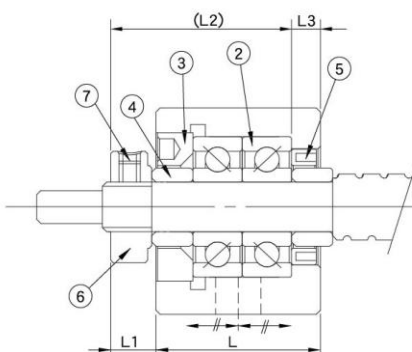
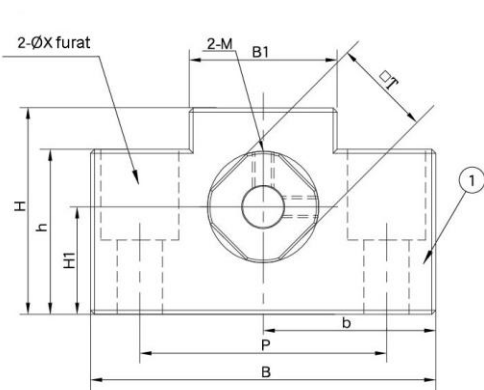

Részlet	Megnevezés	Mennyiség
1	Ház	1 db
2	Csapágy	1 szett
3	Záróelem	1 db
4	Váll	2 db
5	Tömítés	2 db
6	Ellenanya	1 szett
7	Hernyócsavar	2 db

EK10 ~ EK20

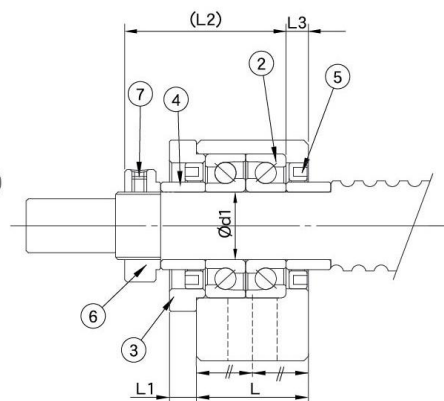
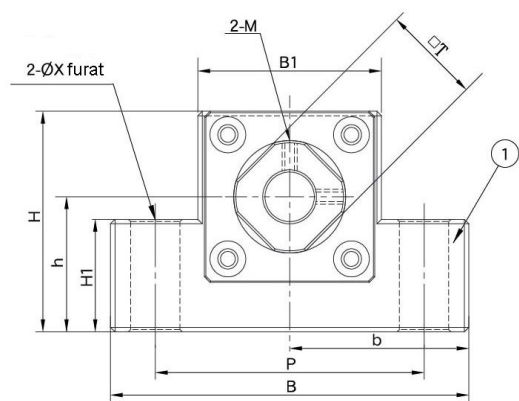

EK10 ~ 20

Termék	Tengely- átmérő d1	L	L1	L2	L3	B	H	b ±0,02	h ±0,02	B1	H1	P	X	Y	Z	M	T	Súly (kg)
EK05	5	16,5	5,5	18,5	3,5	36	21	18	11	20	8	28	4,5	-	-	M3	11	0,12
EK06	6	20	5,5	22	3,5	42	25	21	13	18	20	30	5,5	9,5	11	M3	12	0,18
EK08	8	23	7	26	4	52	32	26	17	25	26	38	6,6	11	12	M3	14	0,27
EK10-1	10	24	6	29,5	6	65	43	32,5	21	36	20	52	6,6	-	-	M3	16	0,47
EK10	10	24	6	29,5	6	70	43	35	25	36	24	52	9	-	-	M3	16	0,47
EK12	12	24	6	29,5	6	70	43	35	25	36	24	52	9	-	-	M4	16	0,45
EK15	15	25	6	36	5	80	49	40	30	41	25	60	11	-	-	M4	22	0,6
EK20	20	42	10	50	10	95	58	47,5	30	56	25	75	11	-	-	M4	30	1,35

az adatok mm-ben értendők