

SLIDE GUIDE

SLIDE GUIDE

NB slide guides are high-precision and high-rigidity linear bearings designed to utilize the motion of rolling elements. They have numerous advantageous characteristics including low friction, no stick-slip, and smooth linear motion even under high load conditions. Since they can maintain their high-efficiency and high-functionality characteristics for an extended period of time, they meet a wide range of needs, from general industrial to precision machinery.

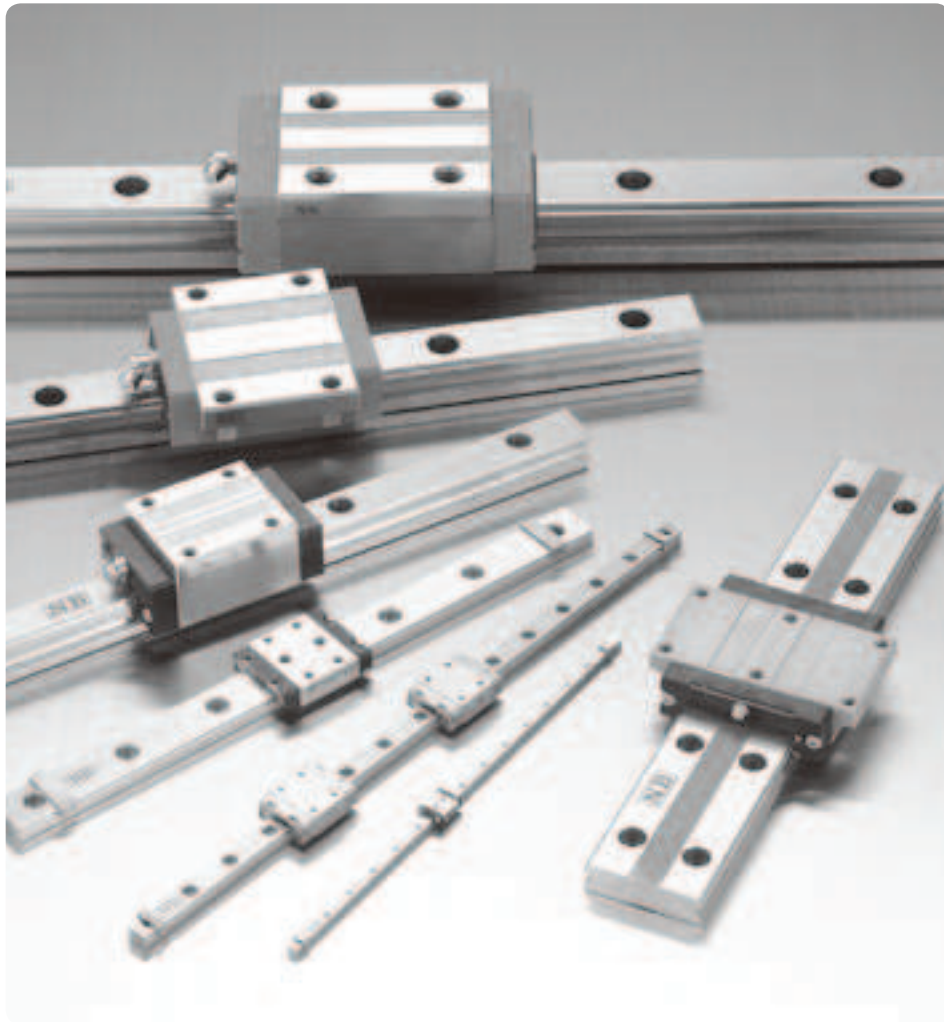

TYPES

Table A-1 Types

rolling element	cross section and contact structure	advantages	page
miniature type	ball retained ball, 2-row, 4-point contact (SEBS-B type) 	<ul style="list-style-type: none"> ● retained ball type ● available with all stainless steel components ● 2-row, compact ● small, light, cost effective 	P.A-20
	2-row, 4-point contact (SEB-A type) 	<ul style="list-style-type: none"> ● 2-row, compact ● small, light, cost effective ● available in various types ● available in stainless steel 	P.A-20
	roller (SER type) 	<ul style="list-style-type: none"> ● miniature roller guide ● cross roller, high precision ● available with all stainless steel components 	P.A-42
high-rigidity type	ball 4-row, 2-point contact (SGL type) 	<ul style="list-style-type: none"> ● high self-centering characteristics ● high load capacity due to relatively large ball elements ● high dust preventive control with side-seals and under-seals ● available in stainless steel 	P.A-50
	4-row, 2-point contact (SGW type) 	<ul style="list-style-type: none"> ● high-moment resistant ● low-height design ● smooth motion due to large number of effective balls ● high dust preventive control with side-seals and under-seals 	P.A-72

ACCURACY MEASUREMENT METHOD

The accuracy of slide guides is measured by fixing the rail to the reference base. The accuracy is expressed in terms of the average value at the center portion.

Dimensional Tolerance and Paired Difference

The accuracy of the slide guide is obtained by measuring the height H, and width W, as shown in Figure A-1. The dimensional tolerance is measured for each of the blocks attached to the rail and is expressed in terms of the deviation from the basic dimension. The paired difference is obtained by measuring the blocks attached to the rail and is expressed in terms of the difference between the maximum and minimum values.

Figure A-1 Accuracy Measurement

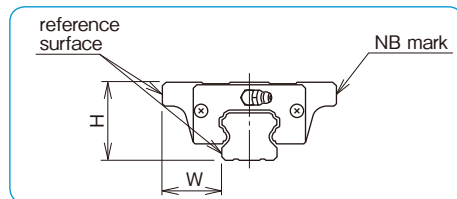

Motion Accuracy

The rail is first fixed to the reference base. The motion accuracy is obtained by measuring the difference in the indicator readings when the block is moved along the entire span of the rail.

Note: Gauge head is placed on the center of the block reference surface.

Figure A-2 Measurement Method for Motion Accuracy

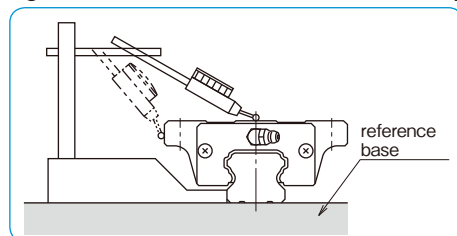

Notation for Number of Axes and Paired Difference

When more than one rail is used in parallel, the dimensional difference must be measured on more than one block on more than one rail. For measuring the paired difference for height H, please specify the number of axes (W2, W3) as the part number example shows. For measuring the paired difference for width W, please contact NB.

Note : When four rails are used as illustrated in Figure A-3, W4 should be specified in the part number. Please indicate the number of axes when ordering.

part number example
SGL25TF2-350/W2
 symbol for number of axes
 W2: 2 parallel axes
 W3: 3 parallel axes

Figure A-3 4 Parallel Axes

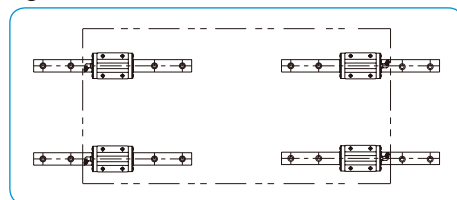

RIGIDITY AND PRELOAD

The rolling elements of the slide guide deform elastically due to the applied load. The amount of deformation depends on the type of rolling element. It is proportional to the 2/3rd power for ball elements. For rollers, it is proportional to the 0.9th power. In either case, the rate of deformation decreases as the applied load increases. Greater rigidity is achieved by applying a preload.

A preload causes internal stress within the slide guide block, resulting in some reduction in lifetime. However, when the guide is used under shock or vibration loading conditions, a preload will absorb the load and will actually help lengthen the life time. Because the preload causes elastic deformation of the rolling elements, it becomes less tolerable to the installation dimensional errors. Extreme care should be exercised in machining the installation surface.

Four levels of preload are available: clearance, standard, light, and medium. This allows the user to select the appropriate level for the application.

Figure A-4 Elastic Deformation of Rolling Elements

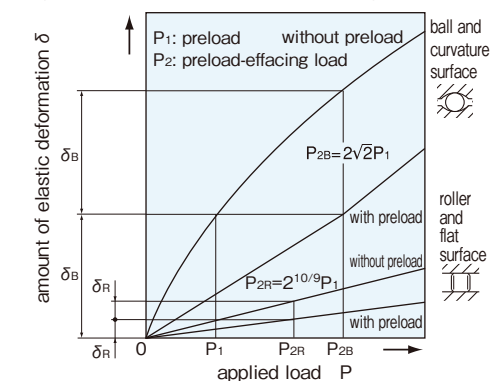

Table A-2 Level of Preload

preload	symbol	effect of preload					operating conditions	applicable part number
		vibration absorption ability	self-aligning ability	lifetime	rigidity	frictional resistance		
clearance	T0	increases	reduces	reduces	increases	increases	light motion is required. installation errors to be absorbed.	SEB
standard	blank	increases	reduces	reduces	increases	increases	minute vibration is applied. accurate motion is required. moment is applied in a given direction.	SEB,SGL SGW
light	T1	increases	reduces	reduces	increases	increases	light vibration is applied. light torsional load is applied. moment is applied.	SEB,SGL SGW
medium	T2	increases	reduces	reduces	increases	increases	shock and vibration are applied. over-hang load is applied. torsional load is applied.	SGL,SGW

LOAD RATING AND RATED LIFE

Loading Direction and Load Rating

A slide guide experiences load and moment, as shown in Figure A-5. For each load and moment, the basic load ratings and allowable static moments are defined.

Figure A-5 Direction of Load

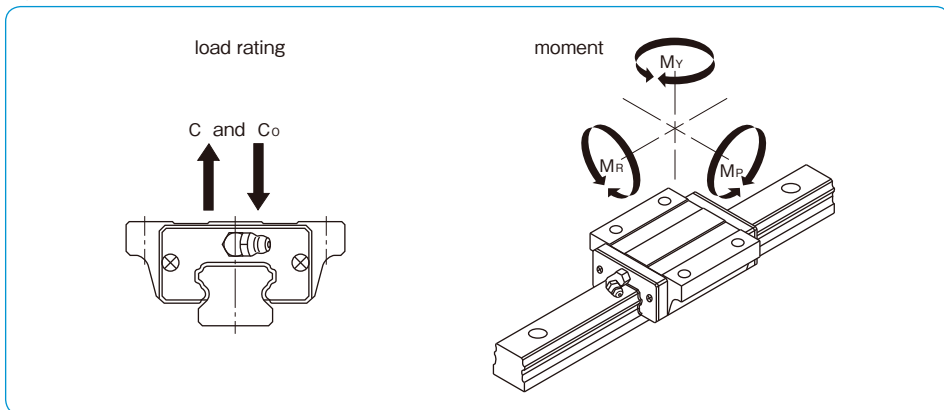

Rated Life Calculation

Two types of rolling elements are used in NB slide guides: ball and roller elements. There is a different equation for calculating the rated life of each type.

For ball elements (SEB, SGL, and SGW types), the equation is

$$L = \left(\frac{f_c \cdot f_T}{f_w} \cdot \frac{C}{P} \right)^3 \cdot 50$$

For roller elements (SER type), the equation is

$$L = \left(\frac{f_c \cdot f_T}{f_w} \cdot \frac{C}{P} \right)^{10/3} \cdot 50$$

L: rated life (km) f_c : contact coefficient
 f_T : temperature coefficient f_w : applied load coefficient
 C: basic dynamic load rating (N) P: applied load (N)
 ※ Refer to page Eng-5 for the coefficients.
 ※ The contact coefficient is applied when two or more blocks are used in close contact.

If the stroke length and cycles are constant, life can be expressed in terms of time, the equation is

$$L_h = \frac{L \cdot 10^3}{2 \cdot \ell \cdot s \cdot n \cdot 60}$$

L_h : life time (hr) ℓ s: stroke length (m)
 L: rated life (km) n: number of cycles per minute (cpm)

MOUNTING

Slide guides have high load ratings in spite of their compact size. They can be used in various types of machinery and other equipment in various configurations. Figure A-6 shows some typical slide guide arrangements.

Figure A-6 Slide Guide Arrangements

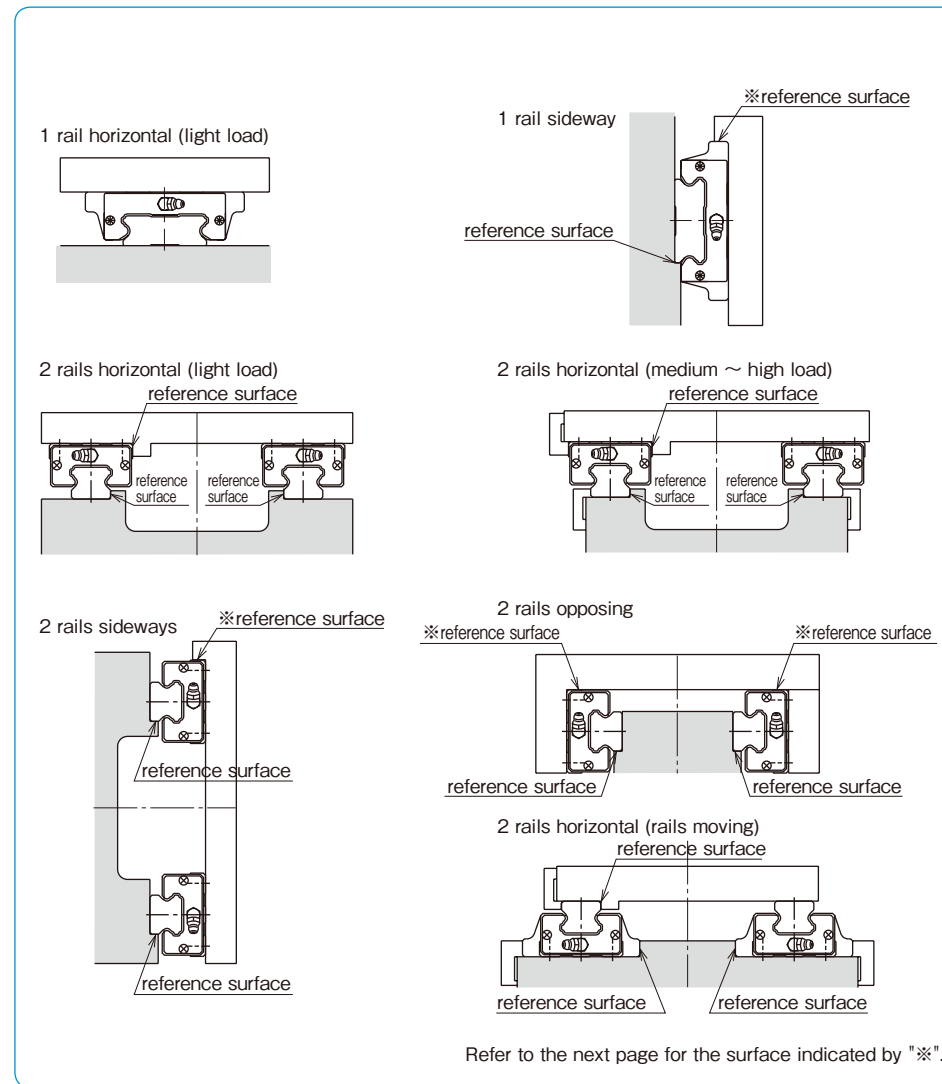

Mounting Surface and Accuracy

NB slide guides are designed and fabricated to achieve high accuracy after mounting them to a machined mounting base. One typical way is to provide a shoulder on the mounting surface and align the reference surface of the rail or block against the shoulder (Figure A-7). To avoid corner interference, an escape groove should be provided at the shoulder corner. Alternatively, the radius of the shoulder corner should be smaller than the radius of the slide guide block/rail corner.

The accuracy of the rail mounting surface affects the accuracy of the machinery or equipment along with the slide guide motion accuracy.

The accuracy of the mounting surface should be equivalent to that of the slide guide motion accuracy. The specified preload may not be achieved due to deformation of the block, for example, the mounted block surface is not flat (Figure A-8). Careful attention should therefore be given to achieve the specified flatness.

Note: Please contact NB for the rail straightness in case the mounting shoulder cannot be provided or the rigidity of the mounting surface is not enough.

Reference Surface Indication

Reference surfaces are provided to enable accurate and simplified mounting. They are located on the same side, as shown in Figure A-9, opposite to the NB mark.

Depending on the mounting arrangement, the standard reference surface may not ensure mounting accuracy (for example, 1 rail sideways or 2 rails opposing, Figure A-6, page A-7). In such cases, NB can provide a reference surface on the opposite side. Please specify the side when ordering.

Figure A-7 Profile of Mounting Reference Surface

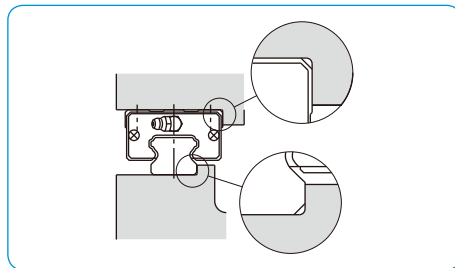

Figure A-8 Effect of Flatness

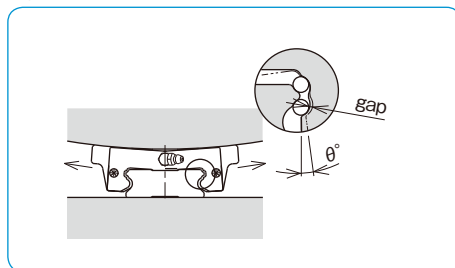
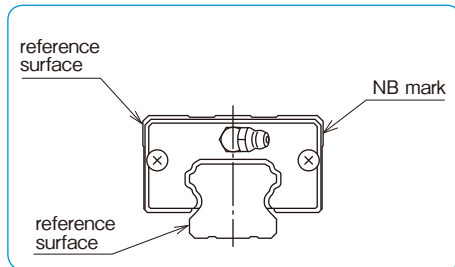

Figure A-9 Reference Surface



Mounting

In general, slide guides are used with 2 rails in parallel. In that case, one rail is on the so-called reference side and the other is on the so-called adjustable side.

- Applications where shock/vibration and high load are involved/high accuracy is required. The effect of shock and vibration on accuracy is eliminated by using side pieces such as side plates (Figure A-10), tightening set screws (Figure A-11), or tapered gibs (Figure A-12).

Figure A-11 Using Tightening Set Screw

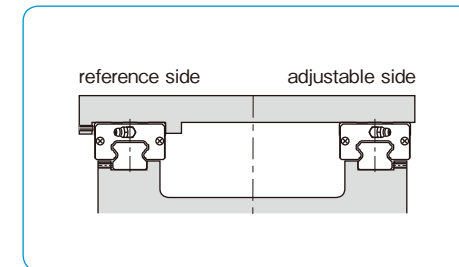

Figure A-10 Using Side Plate

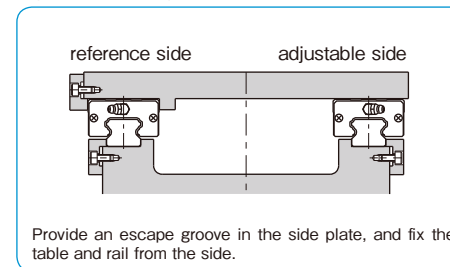
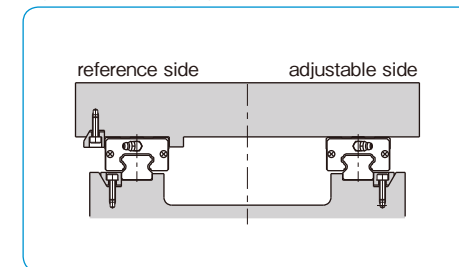

Figure A-12 Using Tapered Gib



- Applications where light load and low speed are involved.

Figures A-13~15 show the mounting methods when high accuracy is not required or the load capacity of the slide guide is sufficient due to a light load or low speed. In these cases, side pieces or reference surface may not be required.

Figure A-14 No Reference Surface on Adjustable Side

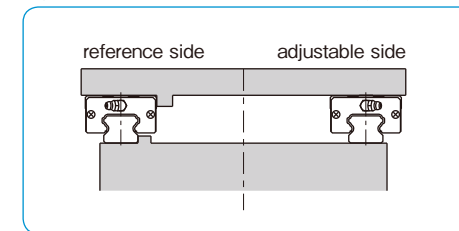

Figure A-13 Without Side Piece

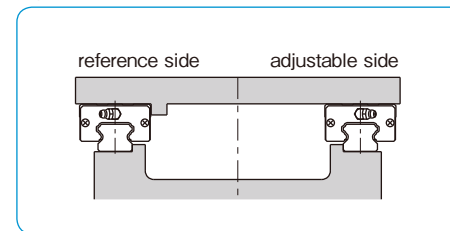
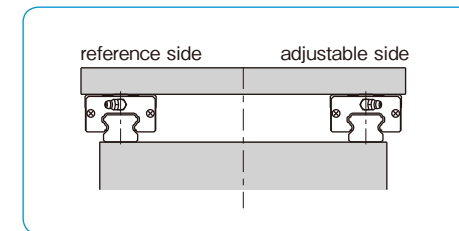

Figure A-15 Without Reference Surface



Mounting Procedure

When reference surfaces are provided for both the table and the base, please follow the following procedure to mount the slide guide.

1. Remove burrs, scratches, dust, etc. from the base and table. Apply a low viscosity oil to the base and the table. Place the slide guide on the base carefully. Temporarily fix the rail mounting screws. (Figure A-16a)

2. Tighten the screw for the side piece so that the installation reference surface and the rail reference surface are in close contact. (Figure A-16b) If a side piece is not provided, use a C clamp to position the mounting reference surface and the rail reference surface so that they contact each other. (Figure A-16d)

3. Tighten the mounting screws to the specified torque, and complete the mounting of the rail. The rail is designed so that its accuracy is optimum when the screws are tightened to the specified value. Please refer to the recommended torque table for each product type. (Figure A-16c)

4. Repeat steps 2 and 3 for the rail on the adjustable side.

5. Move the blocks at the mounting location of the table, and place the table gently. Then slightly tighten the screws. (Figure A-16e)

6. Fix the reference surface of the block against the table by the side piece. Tighten the mounting screws in a diagonal sequence. (Figure A-16f)

7. In the same manner, tighten the mounting screws for the blocks on the adjustable side. (Figure A-16g)

8. Finally, move the table through the stroke length to check if thrust is even. Please repeat 5 and 6 (2 to 6 when necessary) if thrust is not even. If thrust is even, please do final tightening of the screws.

Figure A-16 Mounting Method

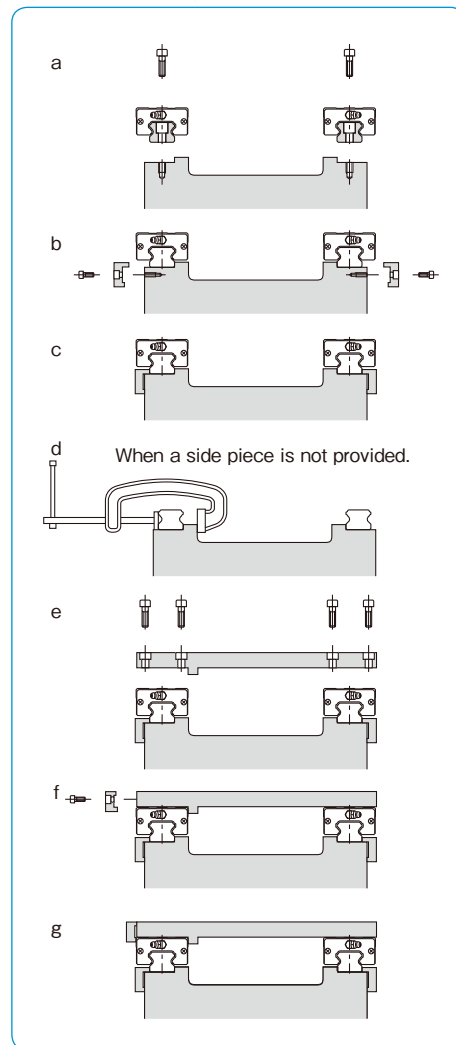

When Reference Surface is Not Provided on Adjustable Side

When a reference surface is not provided on the adjustable side, mount the 2 rails in parallel by using a jig, as mounted in Figure A-17. After mounting the reference-side guide, install the adjustable-side guide by moving the table to achieve parallelism.

Figure A-17 Using a Jig

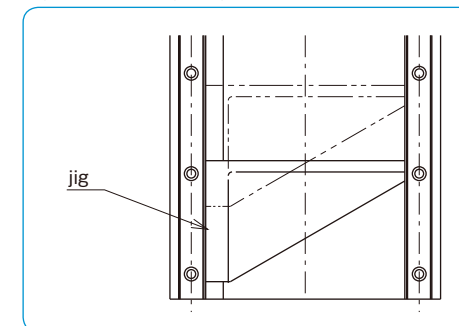

When Reference Surface is Not Provided on Reference Side

When a reference surface is not provided on the reference side, mount the 2 rails by using a reference surface close to the slide guide.

Temporarily fix the slide guide to the base, and mount an indicator on a measurement plate. Please fix the measurement plate on two or more blocks. (Figure A-18)

Place the indicator against the reference surface of the base. Tighten the screws from one end of the rail to ensure straightness.

If there is no reference surface close-by, use a straight edge to achieve straightness. (Figure A-19)

Figure A-18 Using Base Reference Surface

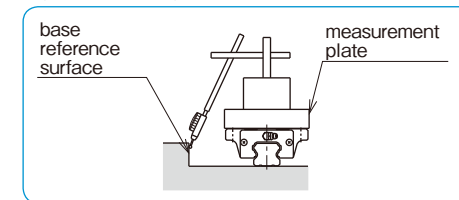
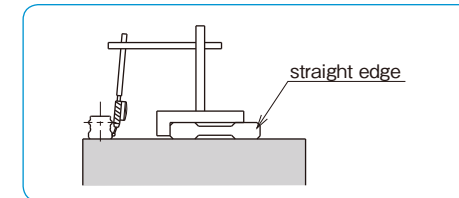

Figure A-19 Using a Straight Edge



NOTES ON HANDLING AND USE

NB Slide Guides are accurately tuned precision components. Please pay special attention to the following notes.

- Please install the Slide Guide as a set. It is not recommended to remove the block for installation.
- When block removal is necessary, please use a temporary (plastic dummy) rail to prevent balls from dropping out.
- To put a guide block on the rail, as the pictures below show, align the reference surface and the height between the rail and a temporary rail. It is very important to maintain the original combination of block(s) and rail.

Figure A-20 How to Put Guide Block on

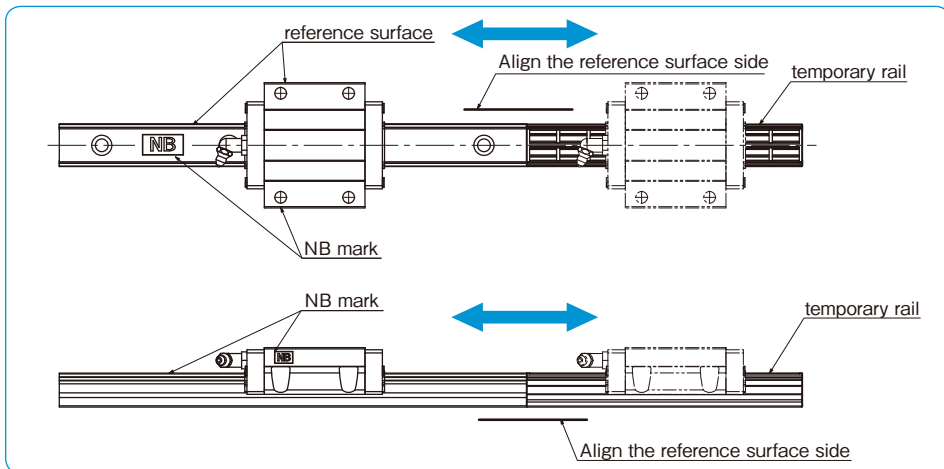

- Please do not turn around a block on the rail to change the grease-fitting orientation. Relocate fitting to the opposite end by removing red plug, and re-insert red plug to where fitting was originally.
- Never try to disassemble the block. This will most assuredly void warranty of the product.
- Please remove burrs, dust, or any other debris from the base and table before installation.
- Slide Guides are pre-lubricated for immediate use. Please relubricate with a similar type of grease regularly. Special lubricants must be matched with the same type of grease to prevent contamination.
- The SEB(S) and SER(S) Slide Guides have metal clip stoppers (picture below) to avoid a block fall-out during shipment and assembly. Please remove the stoppers only after installation is finished with a screwdriver as these clips should not be used as 'mechanical' stoppers.

Figure A-21 How to Take Off Metal Clip

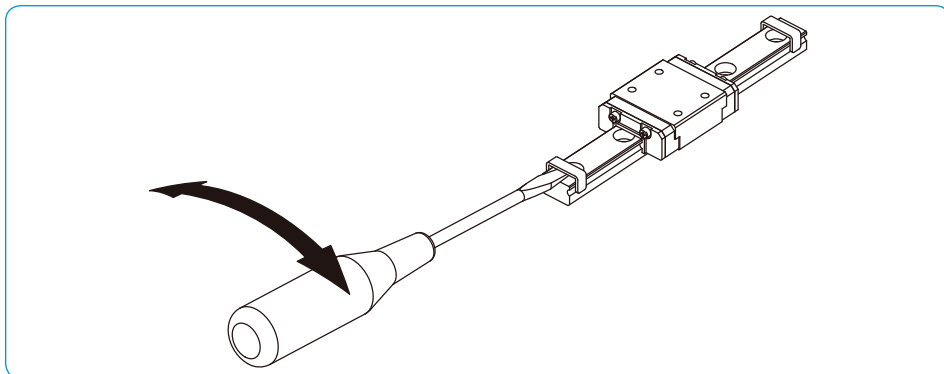

RAIL LENGTH

Guide Rail Length

Please refer to the maximum rail length for each type and size on the dimension table. Unless otherwise specified, the distance from one end of the rail to the first hole center (referred to as dimension "N") is within the range specified in the N dimension tables, satisfying the following equation. Please specify the N dimensions when out of the range.

$$L = M \cdot P + 2N$$

Figure A-22 Rail

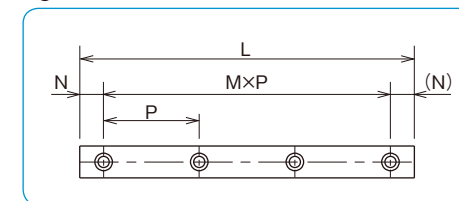

L: length (mm) P: hole pitch (mm)
N: distance from the end of the rail to the first hole center (mm)
M: number of pitches.

JOINT RAILS

Rails can be joined together to obtain a length which exceeds the maximum length. There are two ways to do this.

- Place the joints at the same location for the right and left rails so as to make the design and maintenance simple (Figure A-23 ①).
- Place the joints for the right and left rails at different locations so that the block does not move over the two joints at the same time so as to minimize the effect of the joint on accuracy (Figure A-23 ②).

Please keep the following points in mind when using joint rails.

- To avoid dislocation at joints due to shock loading, provide a shoulder at the joint on the installation side.
- If a shoulder cannot be provided, make sure that any excess load does not change the rail position.
- Use the joint marks provided for installation.
- Tightly butt the rails to be joined so that there is no gap between them.
- Make sure the reference surface side of the joint rails to be aligned.

Note: Joined rails are available for SGL and SGW series with standard grade, high grade, and with standard preload. For joined rails on SEB series, please contact NB. Joined rails are not available for SER series.

Figure A-23 Examples of Joined Guide Rails

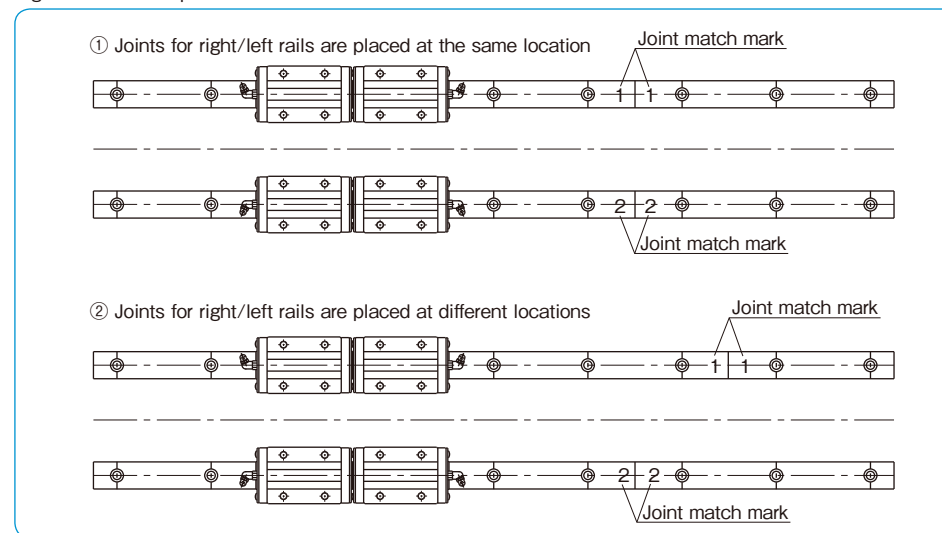

DUST PREVENTION

Seals

Side-Seal

(Series: SEB, SER, SGL, and SGW)

The side-seals prevent foreign particles and dust from entering the guide block in order to retain the motion accuracy, resulting in a long life time.

Under-Seal (Series: SGL and SGW)

Slide guides with side and under-seals are used in harsh environments or to prevent dust entering from below.

Figure A-24 Side-Seal and Under-Seal

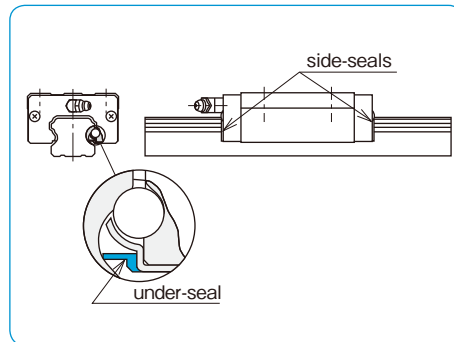

Double Side-Seal Option (Series: SGL)

With this option, the prevention against dust is greatly improved. Ideal for use in applications where bellows or covers are not able to be fitted over the slide guide system.

Figure A-25 Double Side-Seal

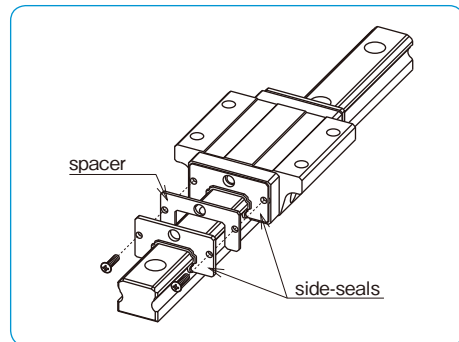

No Side-Seal (Series: SEB and SER)

When the presence of dust or debris is extremely low and only minor motion resistance is desired, a no side-seal option is available. Be aware that, with this option, dust prevention can not be expected.

Scraper Option (Series: SGL)

When the application environment has unfavorable foreign matter or debris such as welding splatter or cutting debris, the scraper option provides an effective protective measure for the slide guide system.

Figure A-26 Scraper

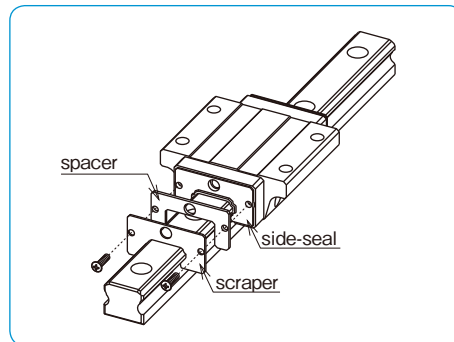

Bellows Option (Series: SGL)

This option fully covers the guide rail preventing dust, debris, and other foreign particles from disrupting the smooth linear motion. (Refer to page A-18 for further details)

Figure A-27 Bellows

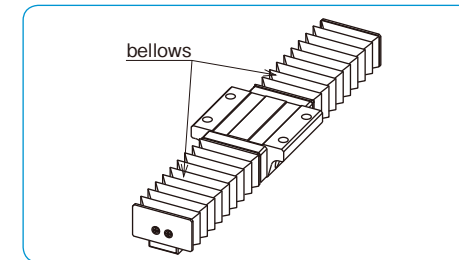

Special Cap

For SGL and SGW guides, special rail mounting caps are available to prevent dust from entering the mounting holes.

These caps are installed, after the rail is fixed to the base, by using a jig and slowly inserting them into the holes until their top surface is flush with the rail surface.

Figure A-28 Special Cap

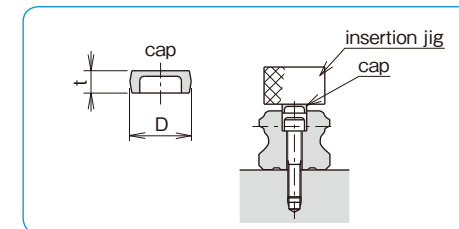

Table A-3 Special Cap

part number	dimensions		applicable part number		
	D mm	t mm	SGL-F,E, TF,TE	SGL-HTF,HYF HTE,HYE,HTEX	SGW
F 3	6.1	1.3	15	—	—
F 4	7.6	1.1	15D	15	17,21,27
F 5	9.7	2.5	20	20	—
F 6	11.2	2.7	25,30	25	35
F 8	14.3	3.65	35	30,35	—
F12	20.3	4.65	—	45	—

ANTI-CORROSION

For anti-corrosion, the SEB/SER series and SGL-F/TF types are available in stainless steel material. Low temperature black chrome treatment can be specified for the SGL and SGW series. This treatment (LB) is suitable for applications where corrosion resistance is a requirement.

LUBRICATION

Lithium soap based grease is applied to NB slide guides prior to shipment for immediate use. Please relubricate with a similar type of grease periodically depending on the operating conditions.

The **Fiber Sheet** and Reverse-Seal are available which significantly extends relubrication period (refer to page A-16, A-17).

For use in clean rooms or vacuum environments, slide guides without grease or slide guides with customer specified grease are also available. Please contact NB.

NB also provides low dust generation grease. Please refer to page Eng-39 for details.

FIBER SHEET

The Fiber Sheet for the SGL and SGW types, significantly extends lubricant replenishment intervals and has an excellent durability even under harsh conditions with dust and debris that absorb lubricant. Embedded in a block, as shown in Figure A-29, it does not change the length of the block. In addition, the Fiber Sheet does not require any change in mounting dimensions, which allows replacement with existing products without a design change.

Figure A-29 Magnified View of the Fiber Sheet

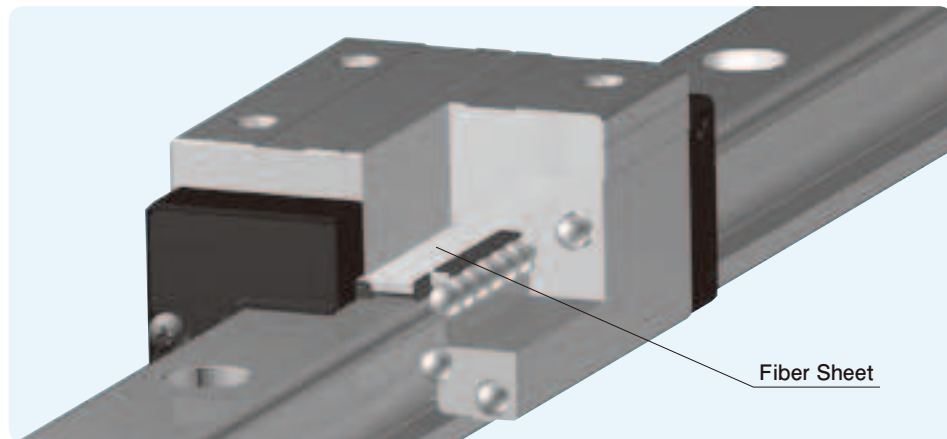

Simplified Lubrication Management

NB's Fiber Sheet is a fiber material with a porous structure containing the lubricant oil. The oil is supplied to the ball elements at the proper time and with the proper amount by the principle of capillarity, greatly increasing the relubrication period.

Figure A-30 Durability Test

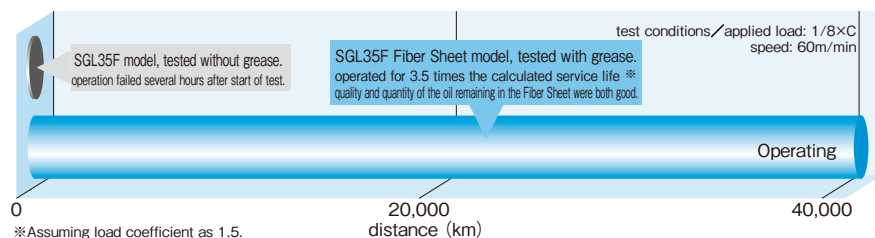

Outstanding Durability Even Under Poor Operating Conditions

An acceleration test was performed with oil absorbing material sprayed on the units to validate the SGL type's lubrication performance and durability even under poor operating conditions.

Figure A-31 Lubrication Acceleration Test

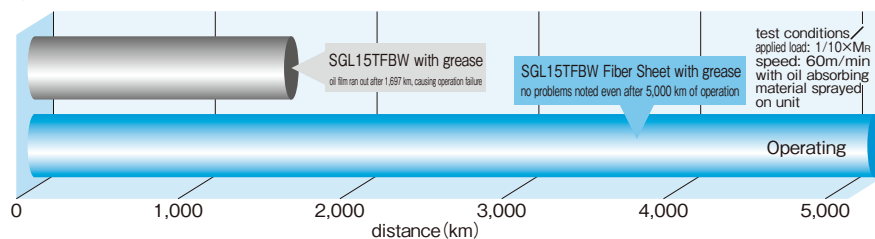

REVERSE-SEAL

NB's Reverse-Seal is a seal unit that consists of reverse plate, seal, and cover. This seal unit has another side-seal in the reverse orientation to the block, which achieves maintenance free by reducing grease loss.

Figure A-32 Reverse-Seal

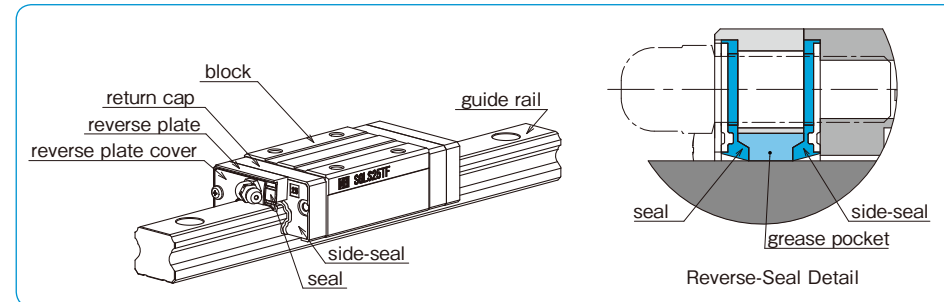

Reducing Grease Leakage

The space between two seals holds grease to minimize a grease leakage from the block.

Figure A-33 Grease-leak Test Data

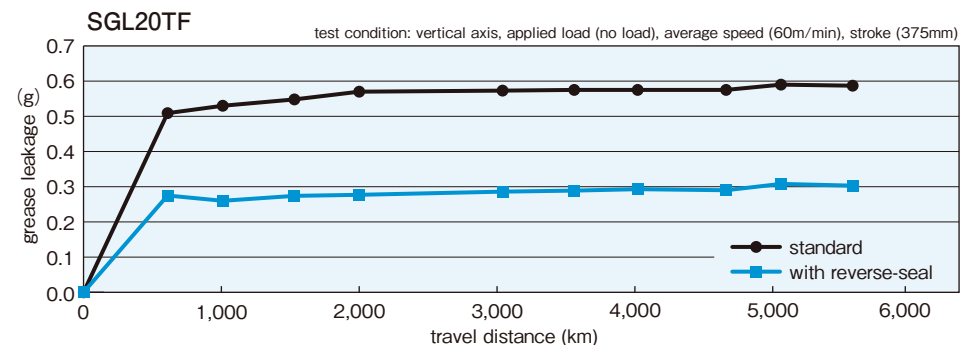

Maintenance Free

Reverse-seal makes a "Grease Pocket" between two seals that realizes maintenance free by reducing grease leakage and loss.

Figure A-34 Grease Dry-up Test Data

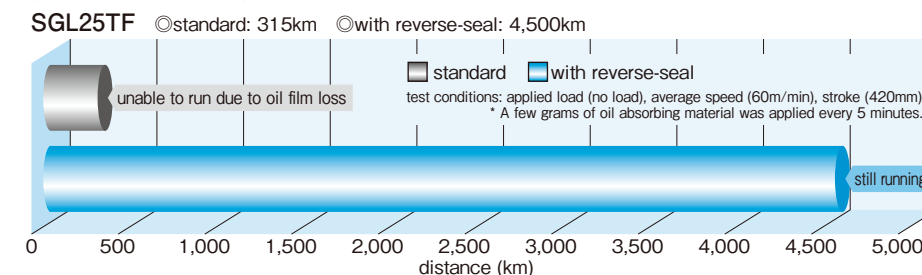

Applicable Part Number

Reverse-Seal (BR option) is available on SGL15,20, and 25.

BELLOWS

By protecting the entire length of the guide rail, the dust prevention is greatly enhanced. Please refer to Figure A-35 for dimensions. External dimensions and the stroke length of slide guide will change with use of bellows.

Figure A-35 Dimensions of Slide Guide with Bellows

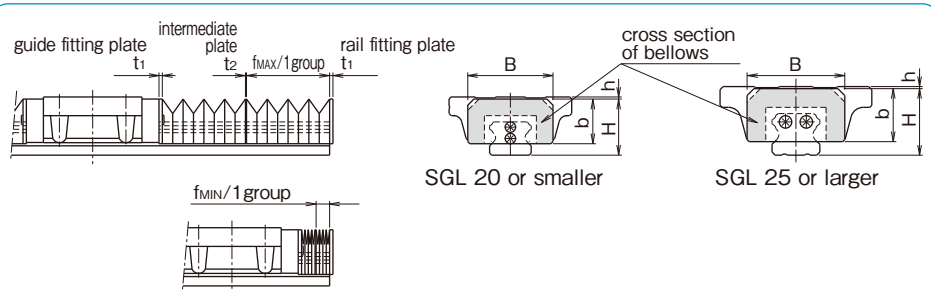

Note: Please do not unfasten the guide fitting plate screws. The slide guide becomes unfunctional if the guide fitting plate is removed.

part number	B	H	h	b	t1	t2	fMAX/1group	fMIN/1group
SGL15F/TF/E/TE	33	23	1	19	1.5	1.0	32	6.5
SGL15HTE/HYE/HTEX			5					
SGL15HTF/HYF			3					
SGL20F/TF/E/TE	41	27	1	21.5				
SGL20HTF/HYF/HTE/HYE/HTEX			3					
SGL25F/TF/E/TE			1					
SGL25HTF/HYF	47	32	8	25.5				
SGL25HTE/HYE/HTEX			4					
SGL30F/TF/E/TE			2					
SGL30HTE/HYE/HTEX	58	40	2	31				
SGL30HTF/HYF			5					
SGL35F/TF/E/TE			2					
SGL35HTE/HYE/HTEX	68	46	9	37				
SGL35HTF/HYF			9					
SGL45HTE/HYE/HTEX			1					
SGL45HTF/HYF	84	59	11	50	2.0	72		
SGL45HTF/HYF			11					

Note: 1 group indicates the minimum unit of bellows. Please specify the required stroke length. When bellows are fitted to the guide block, the grease fitting cannot be installed. Please contact NB for details on the installation of bellows, as well as for special application usage.

Calculation Method of Length of Bellows and Slide Guide Rail

Example: In this case, one(1) piece of SGL15TE guide block is mounted on a rail with bellows; the required stroke is 440mm.

Number of groups required for a stroke of 440mm is calculated as follows.

$$\frac{\text{Stroke}}{f_{\text{MAX}} - f_{\text{MIN}}} = \frac{440}{32 - 6.5} = 17.2 \approx 18 \text{ groups (round up)}$$

When 18 groups of bellows are fitted, the maximum length f_1 is calculated:
 $f_1 = \text{guide fitting plate} + 1\text{group } f_{\text{MAX}} \times \text{number of groups} + \text{intermediate plate} \times (\text{number of groups} - 1)$
 $= 1.5 + 32 \times 18 + 1.0 \times (18 - 1) = 594.5$

When 18 groups of bellows are fitted, the minimum length f_2 is calculated:
 $f_2 = \text{guide fitting plate} + 1\text{group } f_{\text{MIN}} \times \text{number of groups} + \text{intermediate plate} \times (\text{number of groups} - 1)$
 $= 1.5 + 6.5 \times 18 + 1.0 \times (18 - 1) = 135.5$

With these calculation results, stroke limit (S) and length of the guide rail needed (L) are obtained as follows:

$$S = f_1 - f_2 = 594.5 - 135.5 = 459$$

$$L = f_1 + f_2 + \text{SGL15TE block} = 594.5 + 135.5 + 56.5 = 786.5 \approx 787 \text{ (round up)}$$

Figure A-36 External Diagram of Slide Guide with Bellows Attached

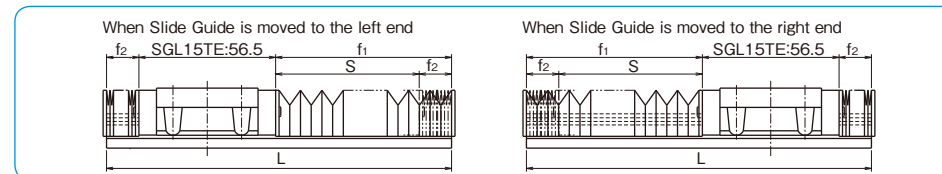

SEB TYPE AD PROFILE (Anti-Deforming)

The AD profile guide block can dissipate possible deformation by improved installation plane profile.

Figure A-37 SEB type AD profile

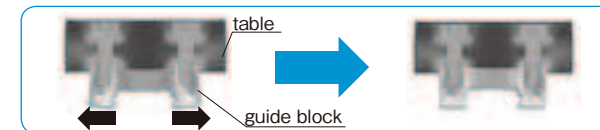

Note:

When NB's unique AD Profile type miniature guide block is selected, the following precautions should be taken into consideration to perform to its utmost advantage.

- To obtain maximum AD (Anti-Deforming) effect, flatness of the mounting surface should be finished the same as motion accuracy of the slide guide.
- When the table is designed with one guide block on one guide rail, the utmost AD effect is anticipated.
- All screws on the slide guide block should be tightened to the equal torque value.
- The AD profile type guide block is available only with standard preload.
- AD profile type guide blocks are available only with following part numbers of slide guide block.

Applicable Part Number

Table A-4 AD profile Applicable Part Number

part number			
SEBS 7B	SEBS 7BM	—	SEBS 7A
SEBS 7BY	SEBS 7BYM		SEBS 7AY
SEBS 9B	SEBS 9BM	SEB 9A	SEBS 9A
SEBS 9BY	SEBS 9BYM	SEB 9AY	SEBS 9AY
SEBS12B	SEBS12BM	SEB12A	SEBS12A
SEBS12BY	SEBS12BYM	SEB12AY	SEBS12AY
SEBS15B	SEBS15BM	SEB15A	SEBS15A
SEBS15BY	SEBS15BYM	SEB15AY	SEBS15AY
SEBS20B	SEBS20BM	SEB20A	SEBS20A
SEBS20BY	SEBS20BYM	SEB20AY	SEBS20AY

part number structure

SEBS 15B UU 2 - 589 N P AD

AD profile

※Please contact NB for details.

SLIDE GUIDE Miniature SEB Type

The NB slide guide SEB type is a linear motion bearing in which the ball elements roll along two raceway grooves. This is the smallest and lightest slide guide series offered by Nippon Bearing. The compact design allows for the size and weight of machinery and other equipment to be reduced.

STRUCTURE AND ADVANTAGES

The SEB type slide guide consists of a rail with precisely machined raceway grooves and a block assembly consisting of the main body, return caps and ball elements.

Retained Ball

Because of the ball retainers, the SEBS-B type is able to be removed from the guide rail, simplifying its installation and resulting in lower assembly costs.

All Stainless Steel Type

By using stainless steel for the return caps, the SEBS-BM type is made of all stainless steel components, making it the ideal choice for special environments such as high temperature, clean room, or vacuum applications.

Moment Resistant

A wide block (WB/WA) type, a long block (BY/AY) type, and a wide/long block (WBY/WAY) type are moment resistant slide guide types. The most

suitable type can be selected for any demanding operating condition.

Tapped Hole Rail Type

For the SEB rails, counterbore (standard) and optional tapped hole (N) types are available enabling various installation methods.

Compact Design

SEB type has a 2-row, 4-point contact structure. This structure minimizes the installation height, which contributes to light-weight and miniaturization of machinery and equipment.

AD Profile

AD profile dissipates guide block deformation caused by installation. (refer to page A-19)

Figure A-38 Structure of SEB type Slide Guide

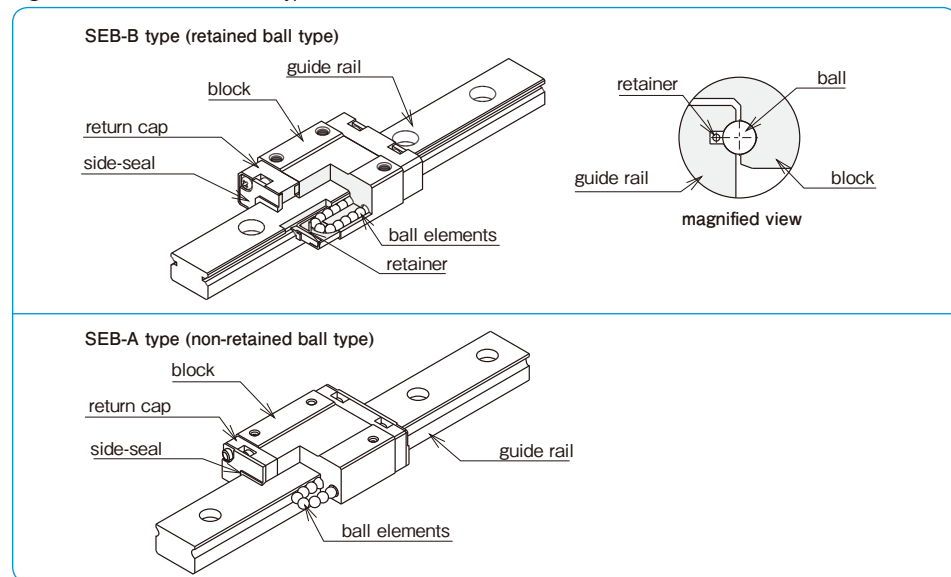

TYPES

The SEB(S) type slide guides are categorized according to their block shape and the rail installation method.

Table A-5 Type

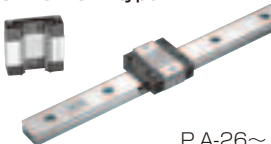
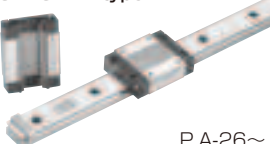
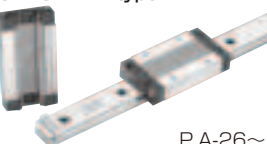
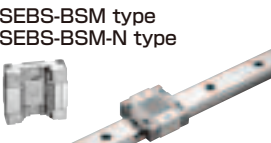
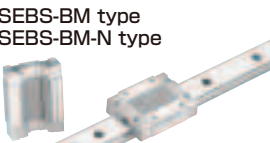
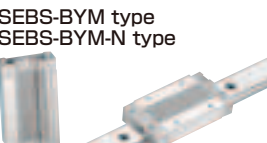
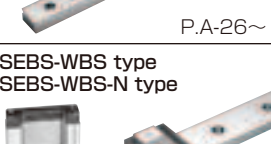
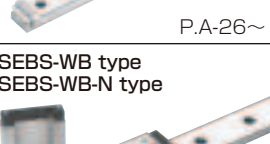
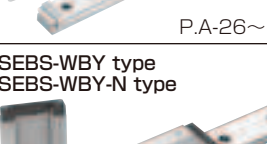
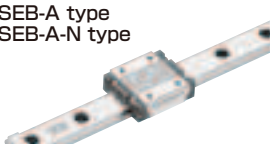
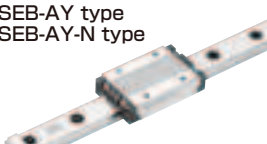
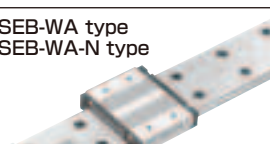
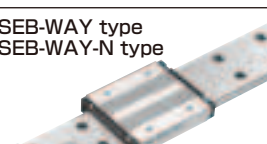
	short block standard type rail(counterbore) N type rail(tapped hole)	standard block standard type rail(counterbore) N type rail(tapped hole)	long block standard type rail(counterbore) N type rail(tapped hole)
retained ball type	SEBS-BS type SEBS-BS-N type  P.A-26~	SEBS-B type SEBS-B-N type  P.A-26~	SEBS-BY type SEBS-BY-N type  P.A-26~
	SEBS-BSM type SEBS-BSM-N type  P.A-26~	SEBS-BM type SEBS-BM-N type  P.A-26~	SEBS-BYM type SEBS-BYM-N type  P.A-26~
	SEBS-WBS type SEBS-WBS-N type  P.A-30~	SEBS-WB type SEBS-WB-N type  P.A-30~	SEBS-WBY type SEBS-WBY-N type  P.A-30~
non-retained ball type	SEB-A type SEB-A-N type  P.A-34~		SEB-AY type SEB-AY-N type  P.A-34~
	SEB-WA type SEB-WA-N type  P.A-38~		SEB-WAY type SEB-WAY-N type  P.A-38~

ACCURACY

The SEB(S) slide guides are available in two grades of accuracy: high grade and precision grade (P).

Table A-6 Accuracy unit / mm

accuracy grade	high	precision
accuracy symbol	blank	P
allowable dimensional difference in height H	±0.020	±0.010
paired difference for height H	0.015	0.007
allowable dimensional difference in width W	±0.025	±0.015
paired difference for width W	0.020	0.010
running parallelism of surface C to surface A	refer to figure A-39,40	
running parallelism of surface D to surface B	refer to figure A-39,40	

Figure A-39 Accuracy

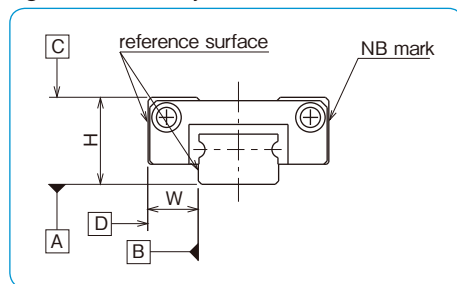
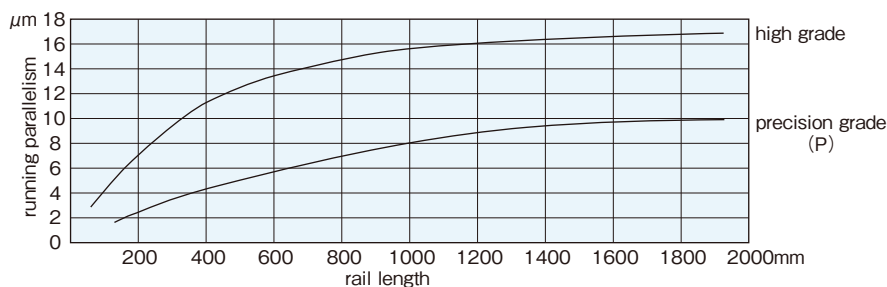

Figure A-40 Motion Accuracy



PRELOAD

SEB(S) slide guides are available with a standard preload (blank), light preload (T1), and a positive-clearance (T0).

Table A-7 Preload Symbol and Radial Clearance unit / µm

size	preload and symbol		
	clearance T0	standard blank	light T1
2	+1~+3	-	-
3		-	-
5		-1~0	-
7	+3~+6	-3~0	-4~-2
9			-4~-2
12			-4~-2
15	+4~+8	-3~0	-7~-3
20			-7~-3
3W			-7~-3
5W	+1~+3	-1~0	-
7W			-
9W			-
12W	+3~+6	-3~0	-4~-2
15W			-4~-2
15W	+4~+8	-1~0	-7~-3

Table A-8 Operating Conditions and Preload

preload	symbol	operating conditions
clearance	T0	light motion is required. installation errors to be absorbed.
standard	blank	minute vibration is applied. accurate motion is required. moment is applied in a given direction.
light	T1	light vibration is applied. light torsional load is applied. moment is applied.

LOAD RATING

The load rating for SEB(S) slide guides depends on the direction of load.

Table A-9 Load Rating

		retained ball type	non-retained ball type
basic dynamic load rating	vertical	1.00 × C	1.00 × C
	horizontal	0.89 × C	1.13 × C
basic static load rating	vertical	1.00 × C ₀	1.00 × C ₀
	horizontal	0.84 × C ₀	1.19 × C ₀

EQUIVALENT LOAD

For a guide to which vertical load and horizontal load are applied at the same time, calculate its static equivalent load using the following equation.

$$P = P_a + X \cdot P_s$$

Figure A-41 Direction of Load

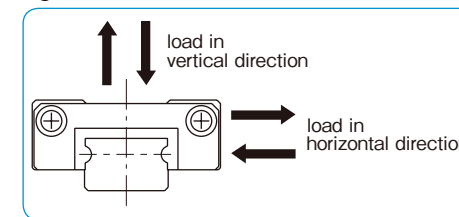

P: equivalent load P_a: vertical load P_s: horizontal load
X: 0.84 for SEB-A type; 1.19 for SEBS-B type

RAIL LENGTH

Slide guides with most commonly used lengths are available as standard. For slide guides with a non-standard length, unless otherwise specified, the distance from one end of the rail to the first hole center (N) will be within the ranges listed in Tables A-10 and A-11, satisfying the following equation.

$$L = M \cdot P + 2N$$

L: length (mm) M: number of pitches P: hole pitch (mm)
N: distance from the end of the rail to the first hole center (mm)

Figure A-42 Rail

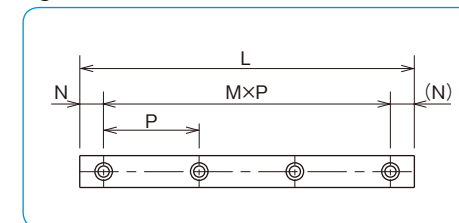

Table A-10 N Dimension (standard type) unit/mm

size	N	
	and over	less than
2	3	7
3		8
5		10.5
7	4	14
9		16.5
12		24
15	6	36
20		36

Table A-11 N Dimension (wide type) unit/mm

size	N	
	and over	less than
3W	3	10.5
5W		14
7W	4	19
9W		19
12W	5	25
15W		25

MOUNTING

Mounting Surface Profile

Slide guides are mounted by pushing the reference surface of the rail and the block against the shoulder provided on the mounting surface. An escape groove or a radius corner should be provided at the corner of the shoulder to prevent interference. The recommended shoulder height values on the mounting reference surface are shown in Table A-12. (Table A-13 for corner radius)

Figure A-43 Mounting Surface Profile-1

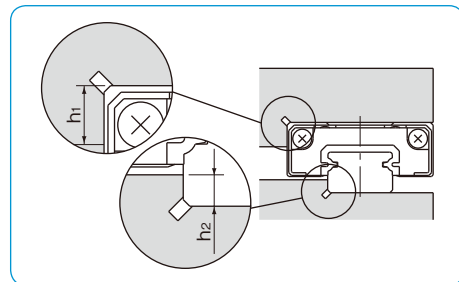

Figure A-44 Mounting Surface Profile-2

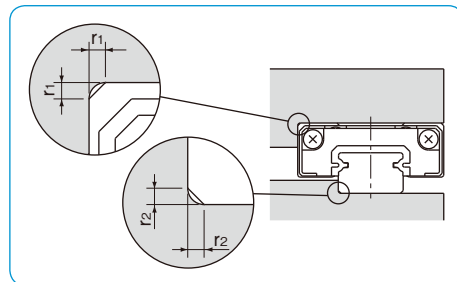

Table A-12 Shoulder Height on the Mounting Reference Surface unit/mm

size	shoulder height on the block side h ₁	shoulder height on the rail side h ₂
2	1	0.5
3	1.2	0.8
5	2	1
7	2.5	
9	3	1.5
12	4	2
15	5	3.5
20		5
3W	1.5	0.8
5W	2	1
7W	3	1.5
9W		2.5
12W	4	
15W	5	

Table A-13 Maximum Corner Radius Values unit/mm

size	block mounting part r ₁	rail mounting part r ₂
2	0.1	0.1
3	0.15	
5	0.3	0.3
7		
9		
12		
15	0.5	
20		
3W	0.15	0.1
5W	0.3	0.3
7W		
9W		
12W		
15W		

Recommended Torque Values

The screws to fasten the rail should be tightened to an equal torque using a torque wrench in order to secure the motion accuracy. The recommended torque values are given in Table A-14. Please adjust the torque depending on the operating conditions.

Table A-14 Recommended Torque unit / N·m

size	M1	M1.4	M1.6	M2	M2.6	M3	M4	M5	M6
recommended torque	0.03	0.10	0.15	0.3	0.65	1.0	2.3	4.7	8.0

(for stainless steel screw A2-70)

MOUNTING SCREW

Extremely small custom screws are available from NB.

Table A-15 Mounting Screw (stainless steel) unit/mm

type	shape	size	D mm	H mm	pitch mm	f mm
custom screw	Figure A-45①	M1	1.8	0.45	0.25	3, 4, 5
		M1.4	2.5	0.8	0.3	2.5, 3, 4
		M1.6	2.3	0.5	0.35	4, 5, 6
		M2	3	0.6	0.4	6
cap screw	Figure A-45②	M2	3.8	2	0.4	4, 5, 6, 8, 10
		M2.6	4.5	2.6	0.45	4, 5, 6, 8, 10

Figure A-45 Mounting Screw

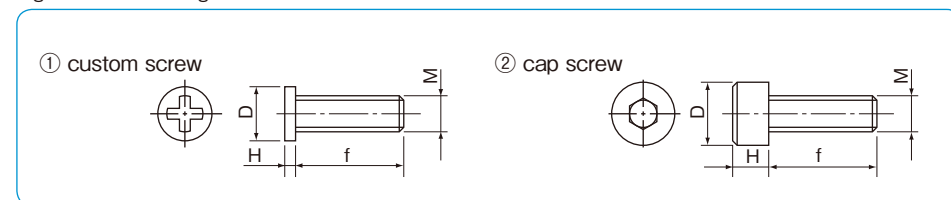

LUBRICATION

A high grade lithium soap based grease is applied to the NB slide guides prior to shipment for immediate use.

Please relubricate with a similar type of grease periodically depending on the operating conditions. For use in clean rooms or vacuum environments, NB slide guides without grease are available upon request.

Please contact NB for customer specified grease types.

A special syringe lubricant dispenser (refer to Figure A-46) is available from NB as an option. In particular, the SEBS-B retained ball type has a special structure that allows the user to replenish lubricant easily (patented), as the magnified view of Figure A-46 shows.

Please refer to page Eng-39 for details on the low dust generation grease.

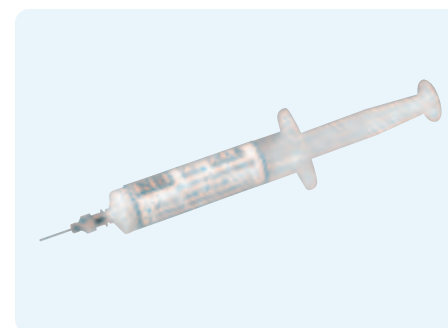
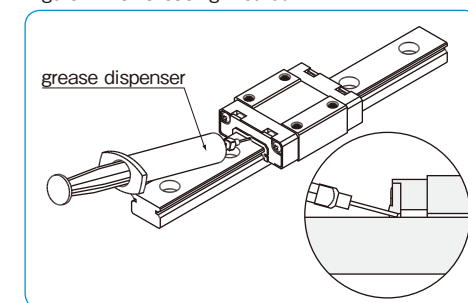
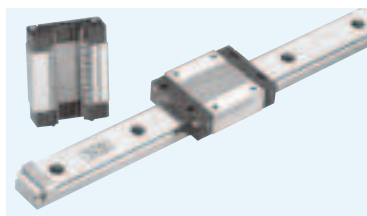

Figure A-46 Greasing Method



SEBS-BS/B/BY TYPE SEBS-BSM/BM/BYM TYPE

— Retained Ball Type —



part number structure

example **SEBS 7B Y M UU 2 T1 -289 N P/W2**

- SEBS: anti-corrosion
- size
- block
- S: short
- blank: standard
- Y: long
- return cap
- blank: resin
- M: stainless steel
- seal
- blank: without side-seal
- UU: with side-seals
- number of blocks attached to one rail
- preload symbol
- TO: clearance
- blank: standard
- T1: light
- symbol for number of axes*
 - blank: single axis
 - W2: 2 parallel axes
 - W3: 3 parallel axes
- accuracy grade
 - blank: high
 - P: precision
- rail mounting hole
 - blank: counterbore
 - N: tapped hole
- total length of rail

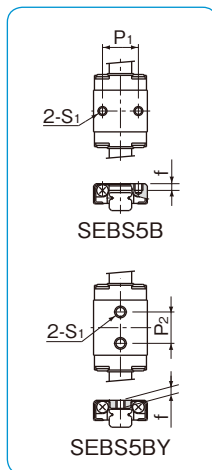

* The symbol for the number of axes does not mean the number of rails ordered.

part number		assembly dimensions		block dimensions									
resin	stainless	H	W	B	L1	L2	P1	P2	S1	f	L3	b	
return cap	return cap	mm	mm	mm	mm	mm	mm	mm	mm	mm	mm	mm	
SEBS 5B	SEBS 5BM	6	3.5	12	16.5	16.9	8	—	M2	1.5	9.3	4.5	
SEBS 5BY	SEBS 5BYM				19.5	19.9	—	7	M2.6	1.8	12.3		
SEBS 7BS	SEBS 7BSM	8	5	17	18.2	19	12	8	M2	2.5	8.8	6.5	
SEBS 7B	SEBS 7BM				22.2	23					13		12.8
SEBS 7BY	SEBS 7BYM				31.7	32.5					13		22.3
SEBS 9BS	SEBS 9BSM	10	5.5	20	20.5	21.3	15	10	M3	3	10.1	7.8	
SEBS 9B	SEBS 9BM				30	30.8					19.6		
SEBS 9BY	SEBS 9BYM				39.5	40.3					16		29.1

part number	standard rail length L mm															
SEBS 5B	40	55	70	85	100	115	130	145	160							
SEBS 7B	40	55	70	85	100	115	130	145	160	175	190	205	220	235	250	265
SEBS 9B	55	75	95	115	135	155	175	195	215	235	255	275	295	315	335	355

Rails exceeding the maximum specified length may be fabricated if joints are used. Please contact NB for assistance.

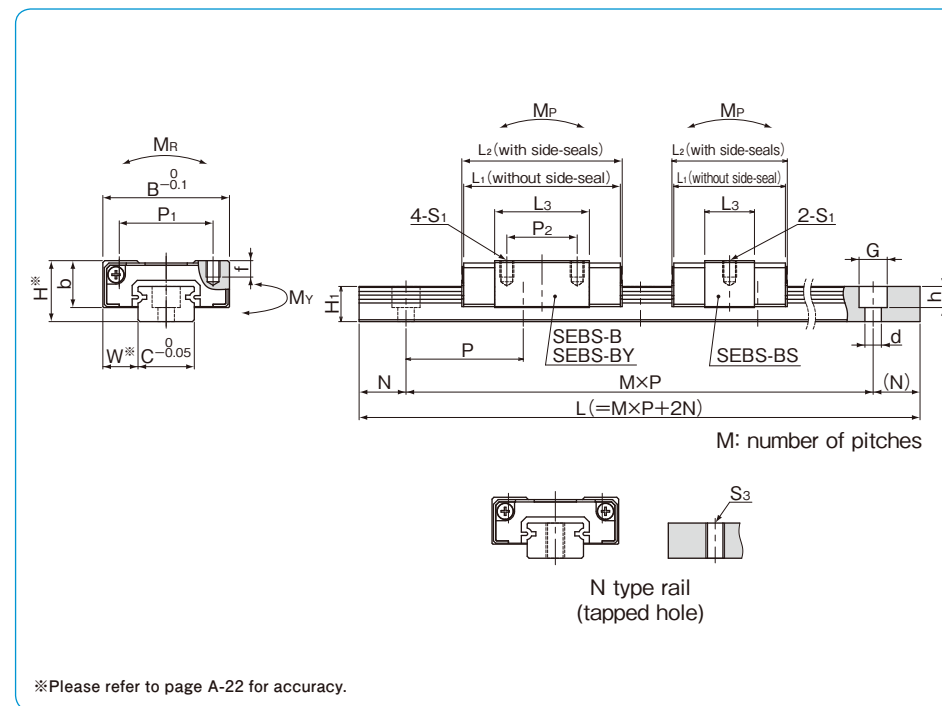

guide rail dimensions						basic load rating		allowable static moment			mass		guide	block size
H1	C	d x G x h	S3	N	P	dynamic C	static Co	Mp N · m	My N · m	Mr N · m	block g resin	block g stainless	rail g/100mm	block size
mm	mm	mm		mm	mm	kN	kN				return cap	return cap		
4	5	2.4 x 3.5 x 0.8	M2.6			0.52	0.75	1.13	0.95	1.96	3	4	13	5B
						0.64	1.00	1.94	1.63	2.62	4	5		5BY
4.7	7	2.4 x 4.2 x 2.3	M3	5	15	0.92	1.05	1.57	1.32	3.86	7	10	21	7BS
						1.28	1.69	3.66	3.07	6.18	9	12		7B
						1.90	2.95	10.4	8.74	10.8	15	18		7BY
5.5	9	3.5 x 6 x 3.5	M4	7.5	20	1.05	1.26	2.17	1.82	5.90	11	15	31	9BS
						1.70	2.53	7.78	6.53	11.8	18	22		9B
						2.26	3.80	16.8	14.1	17.7	27	31		9BY

Mp2 and My2 are allowable static moments when two blocks are used in close contact. 1kN=102kgf 1N · m=0.102kgf · m

						maximum length mm	
						counterbore	tapped hole (N type)
280	295	310				600	300
375	395	415	435	455	475	1,000	700
						1,300	1,000

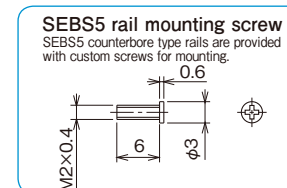

SEBS-BS/B/BY TYPE SEBS-BSM/BM/BYM TYPE

— Retained Ball Type —

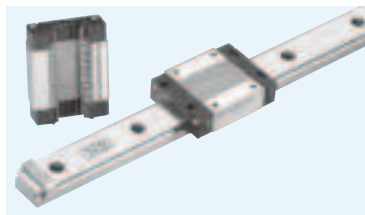

part number structure

example **SEBS 15B Y M UU 2 T1 - 589 N P / W2**

SEBS: anti-corrosion	size	block	S: short	blank: standard	Y: long	return cap	blank: resin	M: stainless steel	seal	blank: without side-seal	UU: with side-seals	number of blocks attached to one rail	preload symbol	TO: clearance	blank: standard	T1: light	symbol for number of axes*	blank: single axis	W2: 2 parallel axes	W3: 3 parallel axes	accuracy grade	blank: high	P: precision	rail mounting hole	blank: counterbore	N: tapped hole	total length of rail
----------------------	------	-------	----------	-----------------	---------	------------	--------------	--------------------	------	--------------------------	---------------------	---------------------------------------	----------------	---------------	-----------------	-----------	----------------------------	--------------------	---------------------	---------------------	----------------	-------------	--------------	--------------------	--------------------	----------------	----------------------

* The symbol for the number of axes does not mean the number of rails ordered.

part number		assembly dimensions		block dimensions										
resin	stainless	H	W	B	L ₁	L ₂	P ₁	P ₂	S ₁	f	L ₃	b	return cap	return cap
mm	mm	mm	mm	mm	mm	mm	mm	mm	mm	mm	mm	mm	mm	mm
SEBS12BS	SEBS12BSM	13	7.5	27	24.2	24.6	20	15	M3	3.5	10.6	10		
SEBS12B	SEBS12BM				33.8	34.2					20.2			
SEBS12BY	SEBS12BYM				45.7	46.1					20			
SEBS15BS	SEBS15BSM	16	8.5	32	30	30.4	25	20	M3	4	15	12		
SEBS15B	SEBS15BM				42.6	43					27.6			
SEBS15BY	SEBS15BYM				58.6	59					25			
SEBS20B	SEBS20BM	25	13	46	65.9	65.9	38	38	M4	6	44.7	17.5		
SEBS20BY	SEBS20BYM				85.7	85.7					64.5			

part number	standard rail length L mm															
SEBS12B	70	95	120	145	170	195	220	245	270	295	320	345	370	395	420	445
SEBS15B	70	110	150	190	230	270	310	350	390	430	470	510	550	590	630	670
SEBS20B	220	280	340	400	460	520	580	640	700	760	820	880	940	1,000		

Rails exceeding the maximum specified length may be fabricated if joints are used. Please contact NB for assistance.

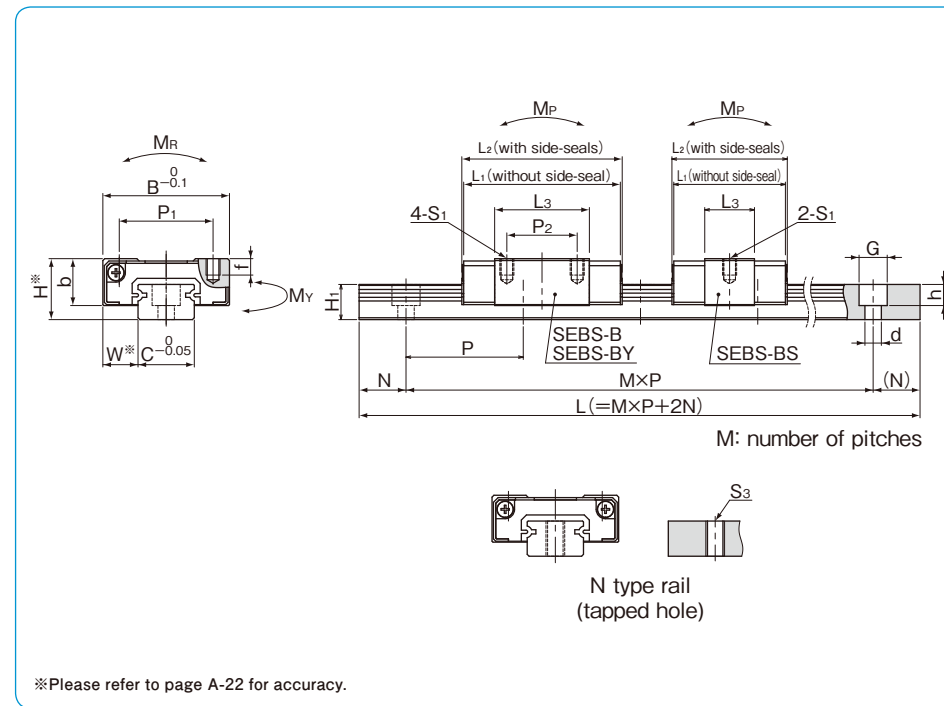

*Please refer to page A-22 for accuracy.

guide rail dimensions						basic load rating		allowable static moment			mass		guide	block size
H ₁	C	d × G × h	S ₃	N	P	dynamic C	static Co	M _P	M _Y	M _R	block g resin return cap	block g stainless return cap	rail g/100mm	block size
mm	mm	mm		mm	mm	kN	kN	N · m	N · m	N · m				
7.5	12	3.5 × 6 × 4.5	M4	10	25	1.90	1.91	3.63	3.04	11.9	21	30	59	12BS
						3.09	3.82	12.4	10.4	23.9	35	44		
						4.34	6.21	30.7	25.7	38.8	53	62		
								170	143					
9.5	15	3.5 × 6 × 4.5	M5	15	40	3.49	3.38	8.56	7.18	26.2	40	53	97	15BS
						5.65	6.76	29.2	24.5	52.4	64	77		
						7.93	10.9	72.4	60.7	85.1	98	110		
15	20	6 × 9.5 × 8.5	M6	20	60	11.4	14.5	103	87.0	149	228	266	205	20B
						14.8	21.2	210	176	217	323	360		
								1,080	914					20BY

M_{P2} and M_{Y2} are allowable static moments when two blocks are used in close contact. 1kN≒102kgf 1N · m≒0.102kgf · m

		maximum length mm	
		counterbore	tapped hole (N type)
470	495	1,300	1,000

SEBS-WBS/WB/WBY TYPE

— Retained Ball • Wide Type —

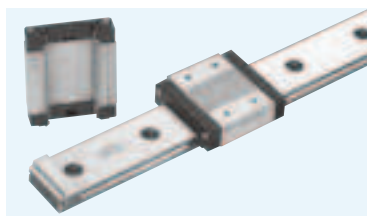

part number structure

example **SEBS 7WB Y UU 2 T1 - 239 N P / W2**

- SEBS**: anti-corrosion
- size**
- block**
S: short
blank: standard
Y: long
- seal**
blank: without side-seal
UU: with side-seals
- number of blocks attached to one rail**
- preload symbol**
TO: clearance
blank: standard
T1: light
- symbol for number of axes***
blank: single axis
W2: 2 parallel axes
W3: 3 parallel axes
- accuracy grade**
blank: high
P: precision
- rail mounting hole**
blank: counterbore
N: tapped hole
- total length of rail**

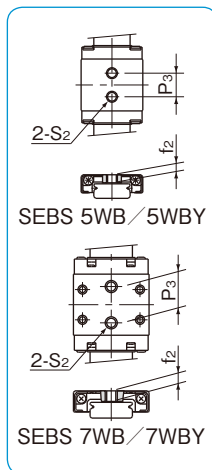

* The symbol for the number of axes does not mean the number of rails ordered.

part number	assembly dimensions			block dimensions										
	H	W	B	L ₁	L ₂	P ₁	P ₂	S ₁	f ₁	L ₃	P ₃	S ₂	f ₂	b
	mm	mm	mm	mm	mm	mm	mm		mm	mm	mm		mm	mm
SEBS 5WB	6.5	3.5	17	21.5	21.9	—	—	—	—	14.3	6.5	M3	2.3	5
SEBS 5WBY				27.5	27.9					20.3	11			
SEBS 7WBS	9	5.5	25	21.1	21.9	19	10	M3	2.8	10.7	—	M4	3.5	7
SEBS 7WB				30.6	31.4					20.2	12			
SEBS 7WBY				39.3	40.1					28.9	18			
SEBS 9WBS	12	6	30	24.2	25	21	—	M3	2.8	13	—	—	—	9
SEBS 9WB				37.5	38.3					26.3	—			
SEBS 9WBY				49.5	50.3					23	24			

part number	standard rail length														
	L mm														
SEBS 5WB	50	70	90	110	130	150	170	190							
SEBS 7WB	50	80	110	140	170	200	230	260	290	320	350	380	410	440	470
SEBS 9WB	50	80	110	140	170	200	230	260	290	320	350	380	410	440	470

Rails exceeding the maximum specified length may be fabricated if joints are used. Please contact NB for assistance.
 The minimum standard rail can not be used for SEBS 9 WBY.

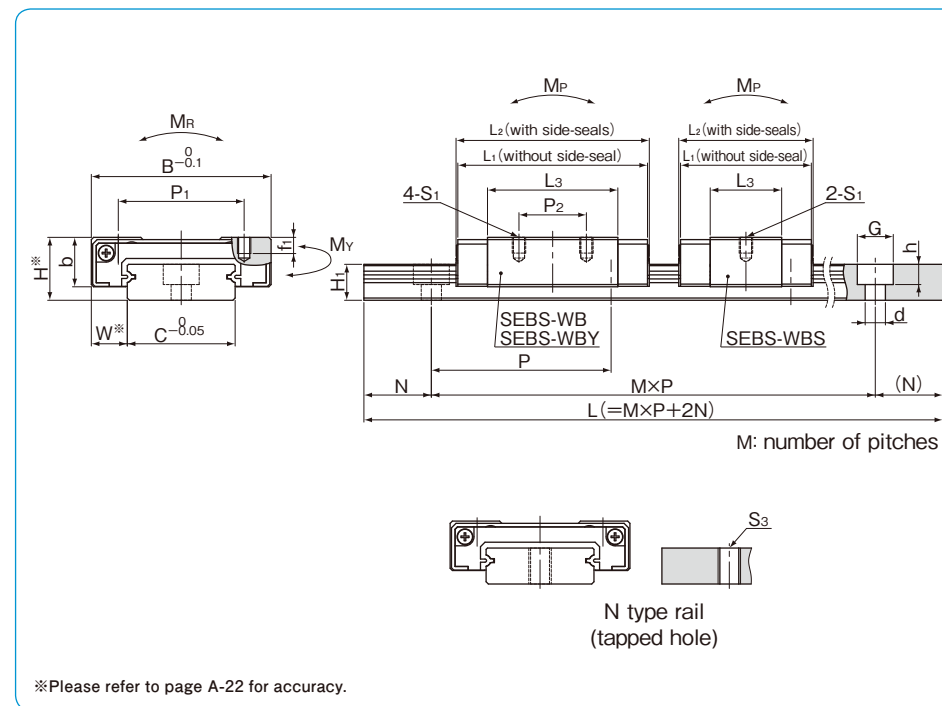

guide rail dimensions							basic load rating			allowable static moment			mass		block size
H ₁	C	B ₁	d × G × h	S ₃	N	P	dynamic C	static C ₀	M _{P2}	M _{Y2}	M _R	block	guide rail	block size	
mm	mm	mm	mm		mm	mm	kN	kN	N · m	N · m	N · m	g	g/100mm		
4	10	—	3 × 5.5 × 3	M3	5	20	0.71	1.17	2.60	2.18	5.99	7	26	5WB	
							0.91	1.68	5.16	4.33	8.56	10			5WBY
5.2	14	—	3.5 × 6 × 3.2	M4	10	30	1.05	1.26	2.17	1.82	9.07	12	51	7WBS	
							1.71	2.53	7.78	6.53	18.1	20		7WB	
							2.26	3.80	48.2	40.4	27.2	28		7WBY	
7.5	18	—	3.5 × 6 × 4.5	M4	10	30	1.73	2.01	4.35	3.65	18.6	21	96	9WBS	
							2.96	4.36	18.1	15.2	40.4	37		9WB	
							3.87	6.38	37.4	31.4	59.0	52		9WBY	

M_{P2} and M_{Y2} are allowable static moments when two blocks are used in close contact. 1kN≒102kgf 1N · m≒0.102kgf · m

	maximum length mm	
	counterbore	tapped hole (N type)
	600	500
	1,000	700
500 530	1,300	1,000

SEBS-WBS/WB/WBY TYPE

— Retained Ball · Wide Type —

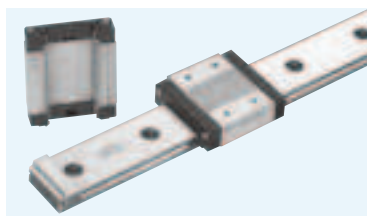

part number structure

example **SEBS15WBYYUU2T1-539NP/W2**

SEBS: anti-corrosion	size	block	S: short blank: standard Y: long	seal	blank: without side-seal UU: with side-seals	number of blocks attached to one rail	preload symbol	TO: clearance blank: standard T1: light	symbol for number of axes*	blank: single axis W2: 2 parallel axes W3: 3 parallel axes	accuracy grade	blank: high P: precision	rail mounting hole	blank: counterbore N: tapped hole	total length of rail
----------------------	------	-------	--	------	---	---------------------------------------	----------------	---	----------------------------	--	----------------	-----------------------------	--------------------	--------------------------------------	----------------------

* The symbol for the number of axes does not mean the number of rails ordered.

part number	assembly dimensions		block dimensions											
	H	W	B	L ₁	L ₂	P ₁	P ₂	S ₁	f ₁	L ₃	P ₃	S ₂	f ₂	b
	mm	mm	mm	mm	mm	mm	mm	mm	mm	mm	mm	mm	mm	mm
SEBS12WBS				29.7	30.1		—			15.9				
SEBS12WB	14	8	40	42.8	43.2	28	15	M3	3.5	29	—	—	—	11
SEBS12WBYY				58.3	58.7		28			44.5				
SEBS15WBS				39.4	39.8		—			24				
SEBS15WB	16	9	60	54.2	54.6	45	20	M4	4.5	38.8	—	—	—	13
SEBS15WBYY				73.3	73.7		35			57.9				

part number	standard rail length														
	L mm														
SEBS12WB	70	110	150	190	230	270	310	350	390	430	470	510	550	590	630
SEBS15WB	70	110	150	190	230	270	310	350	390	430	470	510	550	590	630

Rails exceeding the maximum specified length may be fabricated if joints are used. Please contact NB for assistance.
The minimum standard rail can not be used for SEBS 15 WBYY.

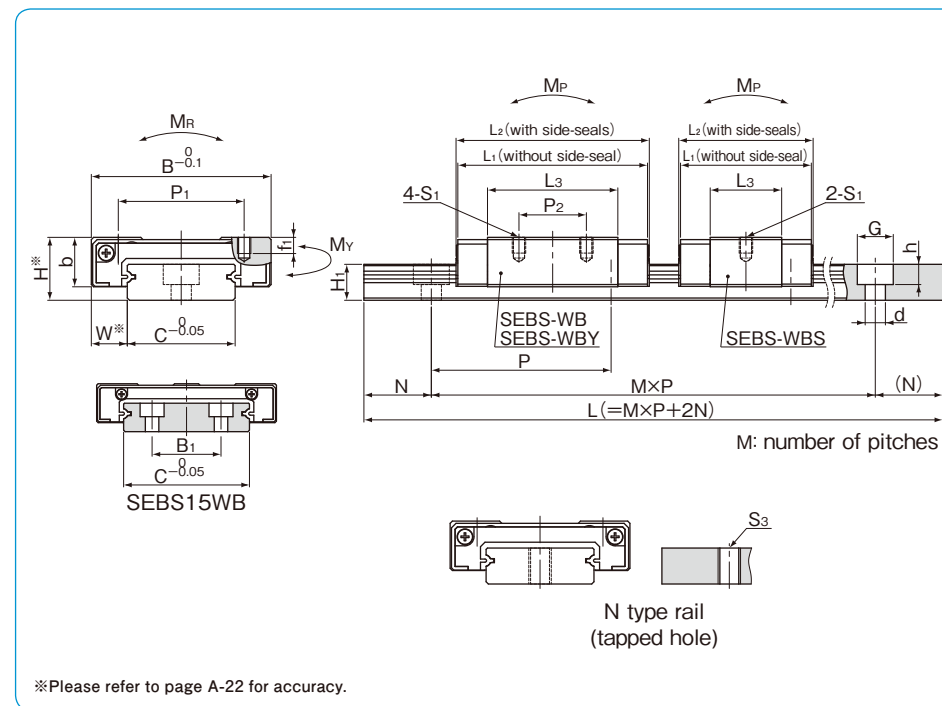

guide rail dimensions							basic load rating			allowable static moment			mass		block size
H ₁	C	B ₁	d × G × h	S ₃	N	P	dynamic C	static C ₀	M _{P2}	M _{Y2}	M _R	block	guide rail		
mm	mm	mm	mm		mm	mm	kN	kN	N · m	N · m	N · m	g	g/100mm		
8	24	—	4.5 × 8 × 4.5	M5	15	40	2.53	2.86	7.38	6.19	35.1	43	137		
							4.10	5.73	26.4	22.1	70.2	71			
							5.45	8.60	57.1	47.9	105	106			
9.5	42	23	4.5 × 8 × 4.5	M5	15	40	5.15	5.91	22.9	19.2	125	98	286		
							7.49	10.1	62.2	52.2	215	148			
							9.95	15.2	134	113	323	216			

M_{P2} and M_{Y2} are allowable static moments when two blocks are used in close contact. 1kN ≒ 102kgf 1N · m ≒ 0.102kgf · m

							maximum length mm	
							counterbore	tapped hole (N type)
670	710							
670	710	750	790	830	870	1,300	1,000	

SEB-A/AY TYPE

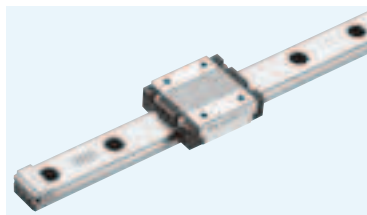

part number structure

example **SEBS 7A Y UU 2 T1 -239 N P /W2**

specification
SEB: standard
SEBS: anti-corrosion

size

block
blank: standard
Y: long

seal
blank: without side-seal
UU: with side-seals

number of blocks attached to one rail

preload symbol
TO: clearance
blank: standard
T1: light

symbol for number of axes*
blank: single axis
W2: 2 parallel axes
W3: 3 parallel axes

accuracy grade
blank: high
P: precision

rail mounting hole
blank: counterbore
N: tapped hole

total length of rail

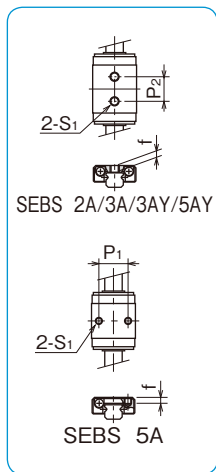

* The symbol for the number of axes does not mean the number of rails ordered.

part number		assembly dimensions		block dimensions								
standard	anti-corrosion	H	W	B	L ₁	L ₂	P ₁	P ₂	S ₁	f	L ₃	b
		mm	mm	mm	mm	mm	mm	mm	mm	mm	mm	mm
—	SEBS 2A	3.2	2	6	12.9	14.3	—	4	M1.4	1.05	9.3	2.5
—	SEBS 3A	4	2.5	8	10.5	11.8	—	3.5	M1.6	1.3	6.5	3
	SEBS 3AY				14.5	15.8	—	5.5	M2		10.5	
—	SEBS 5A	6	3.5	12	15.6	17	8	—	M2	1.5	9.8	4.5
	SEBS 5AY				19.2	20.6	—	7	M2.6	1.8	13.4	
—	SEBS 7A	8	5	17	21.9	24	12	8	M2	2.5	15.1	6.5
	SEBS 7AY				31	33		13			24.6	

part number		standard rail length														
standard	anti-corrosion	L mm														
—	SEBS 2A	32	40	56	80	104										
—	SEBS 3A	30	40	60	80	100										
—	SEBS 5A	40	55	70	85	100	115	130	145	160						
—	SEBS 7A	40	55	70	85	100	115	130	145	160	175	190	205	220	235	250

Joint rails are used when the required length exceeds the maximum standard length listed in the dimension tables. Please contact NB for details. Only N type rail is available for SEBS 2A and SEBS 3A.

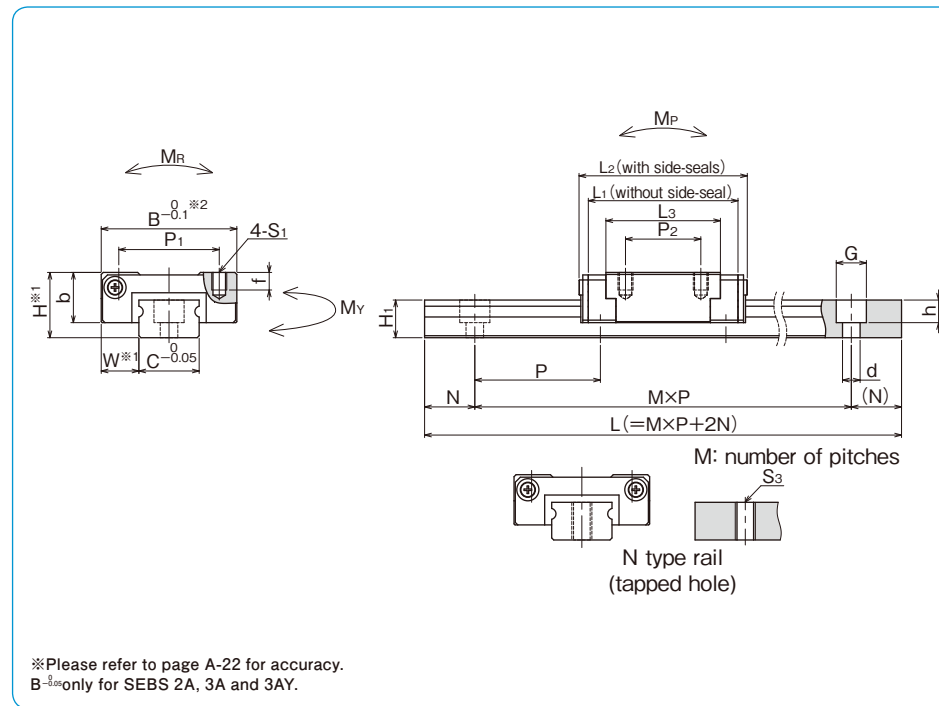

guide rail dimensions						basic load rating		allowable static moment			mass		block size
H ₁	C	d × G × h	S ₃	N	P	dynamic C	static C ₀	M _P MP ₂	M _Y MY ₂	M _R	block g	guide rail g/100mm	
mm	mm	mm		mm	mm	kN	kN	N · m	N · m	N · m			
2	2	—	M1	4	8	0.21	0.38	0.53 2.77	0.64 3.30	0.41	0.8	2.8	2A
2.6	3	—	M1.6	10	15	0.25	0.36	0.39 2.42	0.46 2.88	0.57	1	5	3A
						0.35	0.58	0.97 5.18	1.16 6.18	0.93	2		3AY
4	5	2.4 × 3.5 × 1	M2.6	5	15	0.59	0.81	1.32 8.05	1.58 9.60	2.11	4	13	5A
						0.74	1.11	2.39 13.2	2.86 15.7	2.90	5		5AY
4.7	7	2.4 × 4.2 × 2.3	M3	15	15	1.08	1.41	3.07 18.9	3.66 22.6	5.18	11	21	7A
						1.59	2.48	8.74 45.1	10.4 53.8	9.07	16		7AY

M_{P2} and M_{Y2} are allowable static moments when two blocks are used in close contact. 1kN ≙ 102kgf 1N · m ≙ 0.102kgf · m

	maximum length mm			
	counterbore		tapped hole (N type)	
	standard	anti-corrosion	standard	anti-corrosion
—	—	—	—	150
—	—	—	—	150
—	600	—	—	300
265 280 295 310	—	1,000	—	700

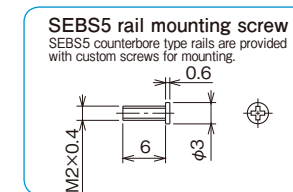

SEB-A/AY TYPE

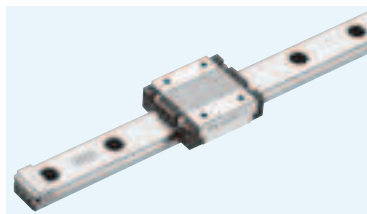

part number structure

example **SEBS 15A Y UU 2 T1 - 539 N P / W2**

specification SEB: standard SEBS: anti-corrosion	size	block blank: standard Y: long	seal blank: without side-seal UU: with side-seals	number of blocks attached to one rail	preload symbol TO: clearance blank: standard T1: light	symbol for number of axes* blank: single axis W2: 2 parallel axes W3: 3 parallel axes	accuracy grade blank: high P: precision	rail mounting hole blank: counterbore N: tapped hole	total length of rail
--	------	-------------------------------------	---	---------------------------------------	---	--	---	--	----------------------

* The symbol for the number of axes does not mean the number of rails ordered.

part number		assembly dimensions		block dimensions									
standard	anti-corrosion	H	W	B	L ₁	L ₂	P ₁	P ₂	S ₁	f	L ₃	b	
		mm	mm	mm	mm	mm	mm	mm		mm	mm	mm	
SEB 9A	SEBS 9A	10	5.5	20	28.1	29.5	15	10	M3	3	20.4	7.8	
SEB 9AY	SEBS 9AY				38.1	40		16			30.4		
SEB 12A	SEBS 12A	13	7.5	27	30	33.5	20	15		3.5	4	22.8	10
SEB 12AY	SEBS 12AY				42	45.5		20				34.7	
SEB 15A	SEBS 15A	16	8.5	32	38.5	42	25	20		6	4	29.5	12
SEB 15AY	SEBS 15AY				54.5	58		25				45.4	
SEB 20A	SEBS 20A	25	13	46	55.7	61	38	38	M4	6	45.7	17.8	
SEB 20AY	SEBS 20AY				79.5	85		38			69.5		

part number		standard rail length														
standard	anti-corrosion	L mm														
SEB 9A	SEBS 9A	55	75	95	115	135	155	175	195	215	235	255	275	295	315	335
SEB 12A	SEBS 12A	70	95	120	145	170	195	220	245	270	295	320	345	370	395	420
SEB 15A	SEBS 15A	70	110	150	190	230	270	310	350	390	430	470	510	550	590	630
SEB 20A	SEBS 20A	220	280	340	400	460	520	580	640	700	760	820	880	940	1,000	

Joint rails are used when the required length exceeds the maximum standard length listed in the dimension tables.

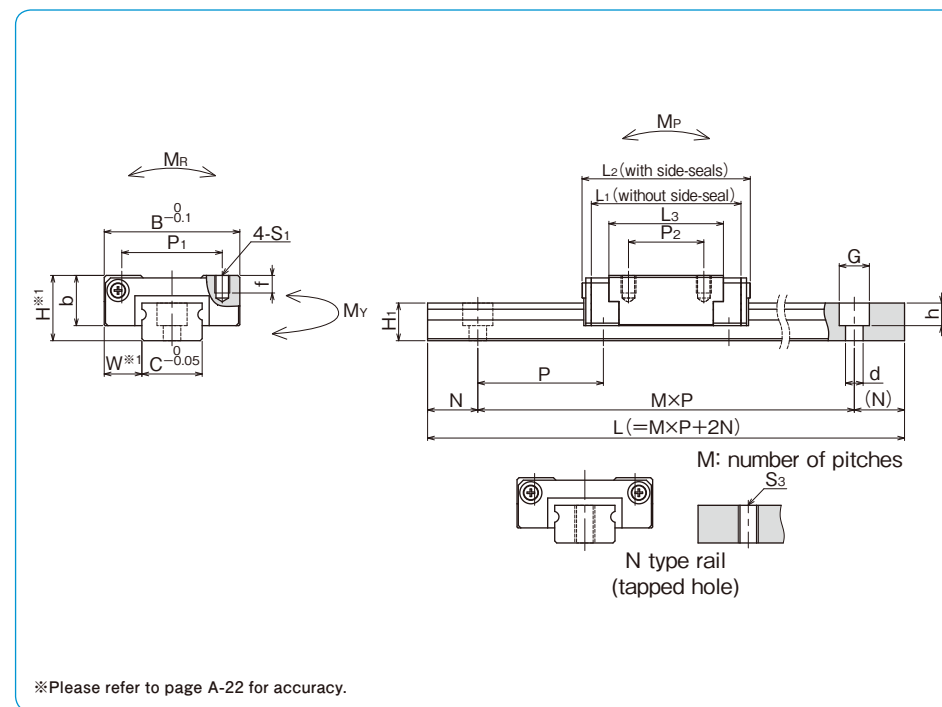

*Please refer to page A-22 for accuracy.

guide rail dimensions						basic load rating		allowable static moment			mass		block size	
H ₁	C	d × G × h	S ₃	N	P	dynamic C	static C ₀	M _P	M _Y	M _R	block	guide rail		
mm	mm	mm		mm	mm	kN	kN	N · m	N · m	N · m	g	g/100mm		
5.5	9	3.5 × 6 × 3.5	M4	7.5	20	1.92	2.53	7.64	9.11	11.5	19	30	9A	
						2.62	3.94	43.1	51.3	20.8	28			9AY
7.5	12	3.5 × 6 × 4.5		10	25	2.60	3.20	10.4	12.4	20.0	37	60	12A	
						3.65	5.21	57.0	68.0	32.6	55			12AY
9.5	15	3.5 × 6 × 4.5		M5	15	40	4.74	5.67	24.5	29.2	43.9	68	100	
							6.65	9.22	131	157	71.4	101		15AY
15	20	6 × 9.5 × 8.5	M6	20	60	8.99	11.1	72.7	86.7	114	226	209	20A	
						12.4	17.8	367	437	182	338			20AY
								176	210	182				
								823	981					

M_{P2} and M_{Y2} are allowable static moments when two blocks are used in close contact. 1kN≒102kgf 1N · m≒0.102kgf · m

				maximum length mm			
		counterbore		tapped hole (N type)			
		standard	anti-corrosion	standard	anti-corrosion		
355	375	395	415	435	455	475	
				500		500	
				1,300		1,000	
				1,900		1,900	

SEB-WA/WAY TYPE

— Wide block —

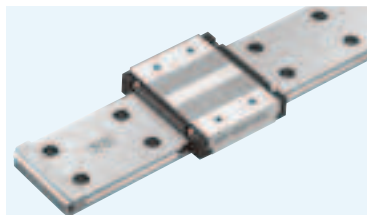

part number structure

example **SEBS 9WA Y UU 2 T1 - 289 N P / W2**

specification
SEB: standard
SEBS: anti-corrosion

size

block
blank: standard
Y: long

seal
blank: without side-seal
UU: with side-seals

number of blocks attached to one rail

preload symbol
TO: clearance
blank: standard
T1: light

symbol for number of axes*
blank: single axis
W2: 2 parallel axes
W3: 3 parallel axes

accuracy grade
blank: high
P: precision

rail mounting hole
blank: counterbore
N: tapped hole

total length of rail

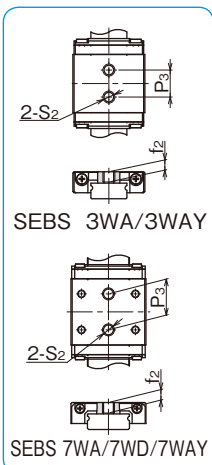

* The symbol for the number of axes does not mean the number of rails ordered.

part number		assembly dimensions		block dimensions											
standard	anti-corrosion	H	W	B	L1	L2	P1	P2	S1	f1	L3	P3	S2	f2	b
mm	mm	mm	mm	mm	mm	mm	mm	mm	mm	mm	mm	mm	mm	mm	mm
—	SEBS 3WA	4.5	3	12	14.2	15	—	—	—	—	9.7	4.5	M2	1.7	3.5
	SEBS 3WAY				19	19.8									
—	SEBS 7WA	9	5.5	25	30.1	32	18	12	M2.6	2.5	22.1	12	M4	3.5	7
	SEBS 7WD				39.6	41	19	M3	2.8						
	SEBS 7WAY									31.6	18				
SEB 9WA	SEBS 9WA	12	6	30	35.9	38	21	12	M2.6	3	28.4	—	—	—	9
SEB 9WD	SEBS 9WD				M3	2.8									
SEB 9WAY	SEBS 9WAY					48	50	23	24	3	40.4				

part number		standard rail length														
standard	anti-corrosion	L														
mm	mm	mm														
—	SEBS 3WA	40	55	70	85	100										
—	SEBS 7WA	50	80	110	140	170	200	230	260	290	320	350	380	410	440	470
SEB 9WA	SEBS 9WA	50	80	110	140	170	200	230	260	290	320	350	380	410	440	470

Joint rails are used when the required length exceeds the maximum standard length listed in the dimension tables. Please contact NB for details. SEB9WAY block lengths exceed the minimum standard rail length.

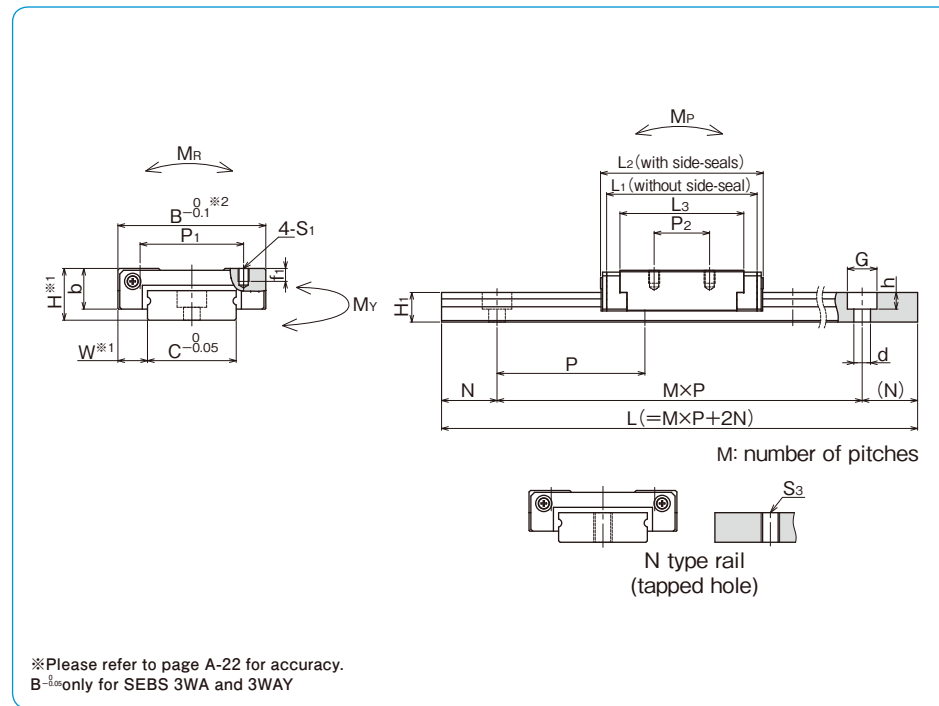

guide rail dimensions							basic load rating		allowable static moment			mass		block size
H1	C	B1	d x G x h	S3	N	P	dynamic C	static Co	MP	MY	MR	block g	guide rail g/100mm	
mm	mm	mm	mm	mm	mm	mm	kN	kN	N · m	N · m	N · m	g	g/100mm	
2.6	6	—	2.4 x 4 x 1.5	M3	5	15	0.33	0.54	0.83	0.99	1.67	3	10	3WA
							0.44	0.81	1.81	2.15	2.51	4	3WAY	
5.2	14	—	3.5 x 6 x 3.2	M4	10	30	1.43	2.12	6.53	7.78	15.2	21	51	7WA
							1.90	3.19	38.2	45.6				7WA
									14.1	16.8	22.8	30	7WAY	
7.5	18	—	3.5 x 6 x 4.5	M4	10	30	2.49	3.66	15.2	18.1	33.9	38	96	9WA
							3.25	5.35	77.6	92.5				9WD
									31.4	37.4	49.5	55	9WAY	

MP2 and MY2 are allowable static moments when two blocks are used in close contact. 1kN≒102kgf 1N · m≒0.102kgf · m

500	530	maximum length mm			
		counterbore standard	anti-corrosion	tapped hole (N type) standard	anti-corrosion
		—	500	—	150
		—	1,000	—	700
		1,900	1,300	1,900	1,000

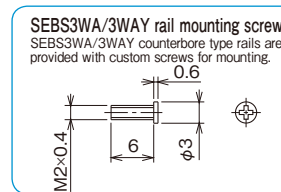

SEB-WA/WAY TYPE

— Wide block —

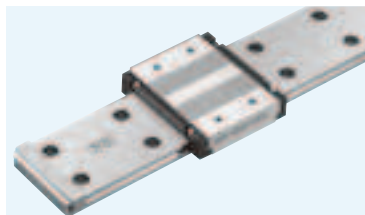

part number structure

example **SEBS 15WA Y UU 2 T1 - 539 N P / W2**

specification SEB: standard SEBS: anti-corrosion	size	block blank: standard Y: long	seal blank: without side-seal UU: with side-seals	number of blocks attached to one rail	preload symbol TO: clearance blank: standard T1: light	symbol for number of axes* blank: single axis W2: 2 parallel axes W3: 3 parallel axes	accuracy grade blank: high P: precision	rail mounting hole blank: counterbore N: tapped hole	total length of rail
--	------	-------------------------------------	---	---------------------------------------	---	--	---	--	----------------------

* The symbol for the number of axes does not mean the number of rails ordered.

part number		assembly dimensions		block dimensions											
standard	anti-corrosion	H	W	B	L ₁	L ₂	P ₁	P ₂	S ₁	f ₁	L ₃	P ₃	S ₂	f ₂	b
mm	mm	mm	mm	mm	mm	mm	mm	mm	mm	mm	mm	mm	mm	mm	mm
SEB12WA	SEBS12WA	14	8	40	40.7	44	28	15	M3	3.5	33.5	-	-	-	11
SEB12WAY	SEBS12WAY				55	58.5		28			47.8				
SEB15WA	SEBS15WA	16	9	60	51.2	55	45	20	M4	4.5	42	-	-	-	13
SEB15WAY	SEBS15WAY				70.5	74		35			61.1				

part number		standard rail length L mm														
standard	anti-corrosion															
SEB12WA	SEBS12WA	70	110	150	190	230	270	310	350	390	430	470	510	550	590	630
SEB15WA	SEBS15WA	70	110	150	190	230	270	310	350	390	430	470	510	550	590	630

Joint rails are used when the required length exceeds the maximum standard length listed in the dimension tables. Please contact NB for details. SEB15WAY block lengths exceed the minimum standard rail length.

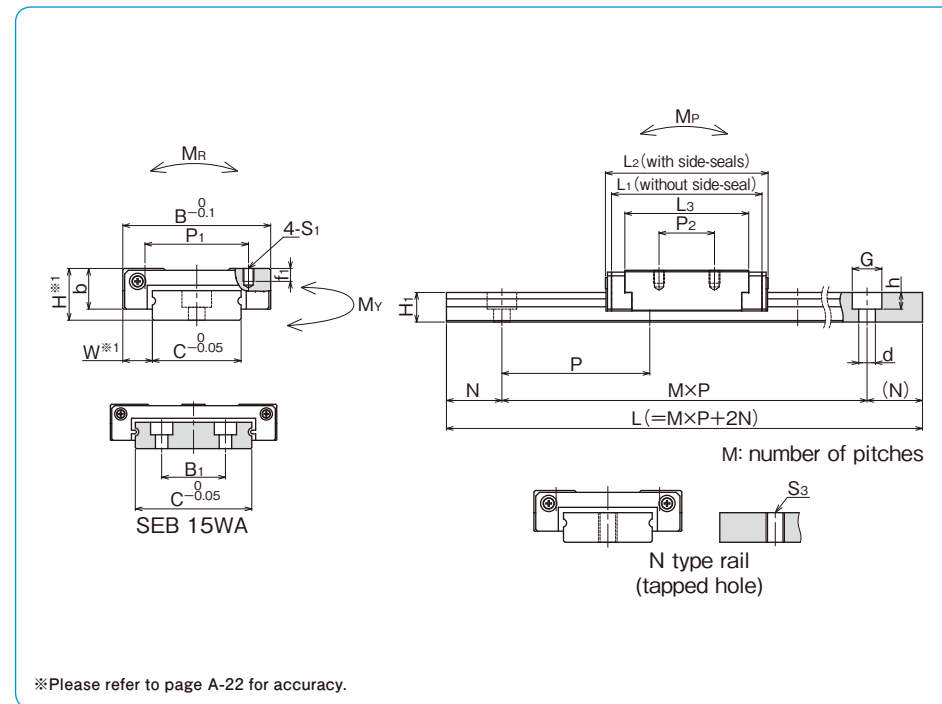

guide rail dimensions							basic load rating		allowable static moment			mass		block size
H ₁	C	B ₁	d × G × h	S ₃	N	P	dynamic C	static C _o	M _P	M _Y	M _R	block g	guide rail g/100mm	
mm	mm	mm	mm		mm	mm	kN	kN	N · m	N · m	N · m	g	g/100mm	
8	24	-	4.5 × 8 × 4.5	M5	15	40	3.64	5.21	25.7	30.7	63.8	77	138	
							4.75	7.62	53.2	63.4	93.3	109		
9.5	42	23	4.5 × 8 × 4.5	M5	15	40	6.29	8.51	52.2	62.2	180	154	294	
							8.35	12.7	113	134	271	222		

M_{P2} and M_{Y2} are allowable static moments when two blocks are used in close contact. 1kN≒102kgf 1N · m≒0.102kgf · m

		maximum length mm			
		counterbore		tapped hole (N type)	
		standard	anti-corrosion	standard	anti-corrosion
670	710	1,900	1,300	1,900	1,000
670	710	750	790	830	870

SLIDE GUIDE Miniature SER Type

The NB slide guide SER type is a linear motion bearing utilizing the rotational motion of precision rollers placed in two rows. Despite its compactness, it can be used in various applications requiring high load capacity.

STRUCTURE AND ADVANTAGES

The SER type slide guide consists of a rail with two precision-machined raceway grooves and a block assembly. The block assembly consists of the main body, rollers, and bottom retainers. All of these components are made of metallic materials.

High Load Capacity and Long Life

Since roller elements are used, the contact surface is large which provides a high load capacity and a long travel life.

Compactness

Since a cross roller method is utilized, only two raceway grooves are necessary and presents a very compact package.

Moment Resistant Type

The wide block design (WA type) has an extremely high moment loading capacity. This will allow for single guide designs in the most demanding and compact applications.

Tapped Hole Rail Type

For the SER rails, counterbore (standard) and optional tapped hole (N) types are available enabling various installation methods.

All Stainless Steel Type

The SERS type slide guide is made of all stainless steel components, making it ideal for high temperature, clean room or vacuum applications.

Figure A-47 Structure of SER type Slide Guide

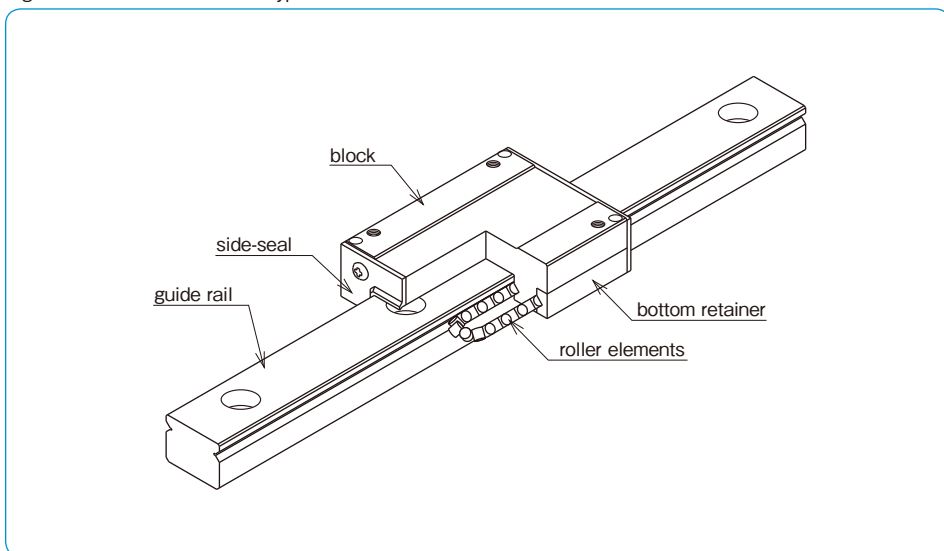

TYPES

The SER type slide guides are available with a standard block or a wide block (WA) configuration. Each type can be selected with standard rails of counterbore holes or the optional N-Type rails of tapped holes. For anti-corrosion, all stainless steel type is also available with all stainless steel components.

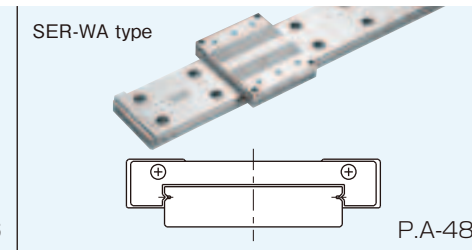
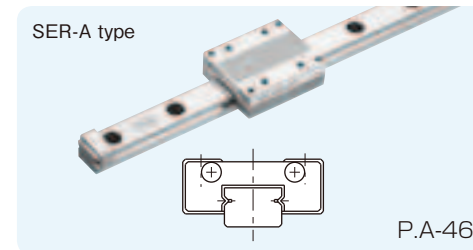

ACCURACY

The SER-type slide guides are available with high grade accuracy (blank) or precision grade accuracy (P).

Table A-16 Accuracy unit / mm

accuracy grade	high	precision
accuracy symbol	blank	P
allowable dimensional difference in height H	±0.015	±0.008
paired difference for height H	0.015	0.007
allowable dimensional difference in width W	±0.020	±0.010
paired difference for width W	0.020	0.010
Running parallelism of surface C to surface A	refer to Figure A-48,49	
Running parallelism of surface D to surface B		

Figure A-48 Accuracy

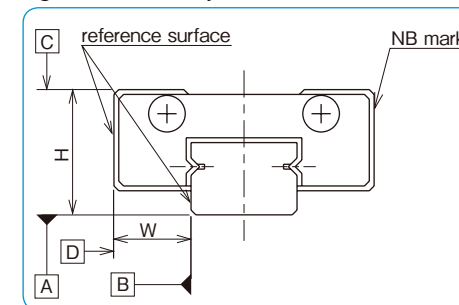
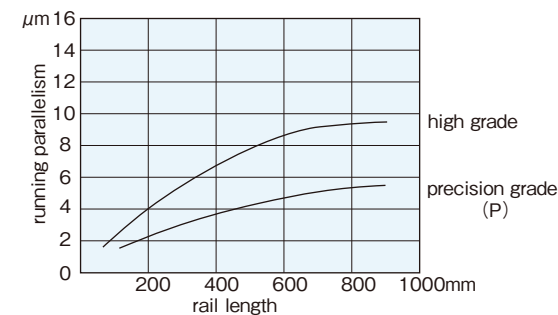

Figure A-49 Motion Accuracy



PRELOAD

The SER(S) type slide guides are available only with a standard (0 to slightly negative clearance) preload.

RAIL LENGTH

Slide guides with most commonly used lengths are available as standard. For slide guides with a non-standard length, unless otherwise specified, the distance from one end of the rail to the first hole center (N) will be within the ranges listed in Tables A-17 and A-18, satisfying the following equation.

$$L = M \cdot P + 2N$$

L: length (mm)
N: distance from the end of the rail to the first hole center (mm)
P: hole pitch (mm) M: number of pitches

Table A-17 N Dimension (standard type) unit/mm

part number		N		L max.
standard	anti-corrosion	and over	less than	
SER 9A	SERS 9A	4	14	275
SER12A	SERS12A		16.5	470
SER15A	SERS15A		24	670
SER20A	SERS20A	6	36	880

Figure A-50 Rail

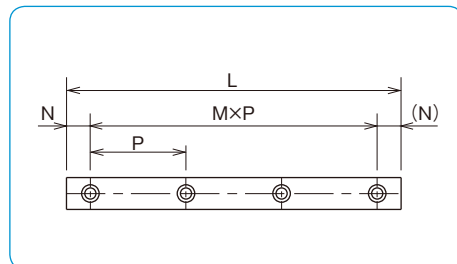

Table A-18 N Dimension (wide type) unit/mm

part number		N		L max.
standard	anti-corrosion	and over	less than	
SER 9WA	SERS 9WA	4	19	290
SER12WA	SERS12WA	5	25	470
SER15WA	SERS15WA			670

MOUNTING

Mounting Surface Profile

Slide guides are mounted by pushing the reference surface of the rail and the block against the shoulder provided on the mounting surface. An escape groove or a radius corner should be provided at the corner of the shoulder, as shown in Figures A-51 and A-52, to prevent interference. The recommended shoulder height and corner radius are shown in Table A-19 and Table A-20 respectively.

Figure A-51 Mounting Reference Surface Profile-1

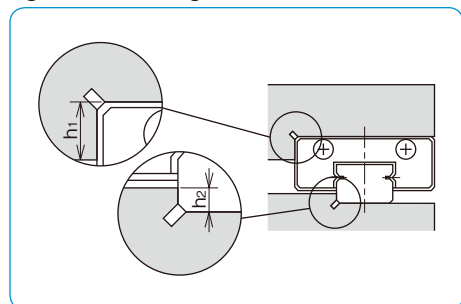

Table A-19 Shoulder Height Dimensions unit/mm

part number	shoulder height on the block side		shoulder height on the rail side	
	h1	h2	h1	h2
SER 9A	3	1.5		
SER12A	4	2		
SER15A	5	3.5		
SER20A		5		
SER 9WA	3	2.5		
SER12WA	4			
SER15WA	5			
SER15WA				

Figure A-52 Mounting Reference Surface Profile-2

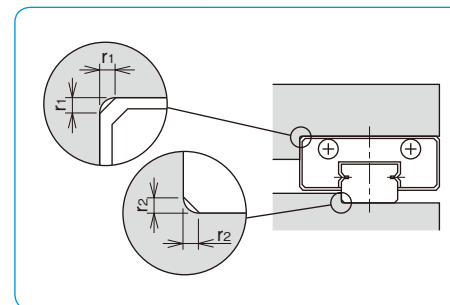

Table A-20 Maximum Corner Radius Values unit/mm

part number	block mounting part	rail mounting part
	r1	r2
SER 9A	0.3	0.1
SER12A		0.3
SER15A		0.5
SER20A		0.3
SER 9WA		0.3
SER12WA		
SER15WA		

Recommended Torque Values

The screws to fasten the rail should be tightened to an equal torque using a torque wrench in order to secure the motion accuracy. The recommended torque values are given in Table A-21. Please adjust the torque depending on the operating conditions.

Table A-21 Recommended Torque unit/N·m

size	M2	M3	M4	M5	M6
recommended torque	0.3	1.0	2.3	4.7	8.0

(for stainless steel screw A2-70)

MOUNTING SCREW

Small screws for the SER(S) type slide guide are available from NB.

Table A-22 unit/mm

size	pitch	length f	application
M2	0.4	4,5,6,8,10	SER 9A

(stainless steel)

Figure A-53 Mounting Screw

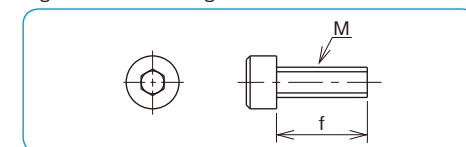

LUBRICATION

A high grade lithium soap based grease is applied to the NB slide guides prior to shipment for immediate use. Please relubricate with a similar type of grease periodically depending on the operating conditions. For use in clean rooms or vacuum environments, NB slide guides without grease are available upon request. Please contact NB for customer specified grease types.

A special syringe lubricant dispenser is available from NB as an option.

Please refer to page Eng-39 for details on the low dust generation grease.

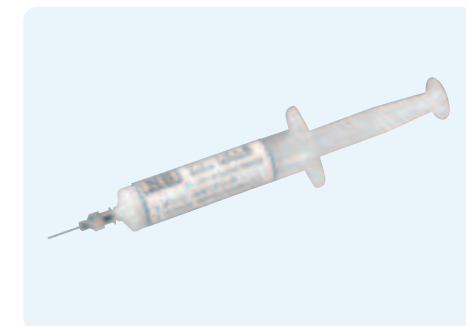

SER-A TYPE

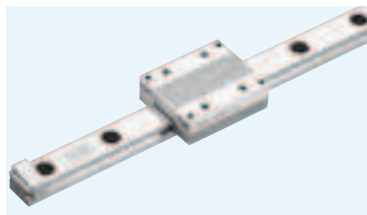

part number structure

example **SERS 15A UU 2-589 N P/W2**

specification SER: standard SERS: anti-corrosion	size	seal blank: without side-seal UU: with side-seals	number of blocks attached to one rail	symbol for number of axes* blank: single axis W2: 2 parallel axes W3: 3 parallel axes	accuracy grade blank: high P: precision	rail mounting hole blank: counterbore N: tapped hole	total length of rail
--	------	---	---------------------------------------	--	---	--	----------------------

* The symbol for the number of axes does not mean the number of rails ordered.

part number		assembly dimensions		block dimensions							
standard	anti-corrosion	H	W	B	L ₁	L ₂	P ₁	P ₂	S ₁	f	b
		mm	mm	mm	mm	mm	mm	mm		mm	mm
SER 9A	SERS 9A	10	5.7	20	28	32	15	13	M2	2.5	7.8
SER12A	SERS12A	13	8	27	32	36	20	15	M3	3	10.5
SER15A	SERS15A	16	8.5	32	40	44	25	20		4	11.5
SER20A	SERS20A	25	13	46	60	66	38	38	M4	6	17.5

part number		standard rail length L							maximum length
standard	anti-corrosion	mm							mm
SER 9A	SERS 9A	55	75	95	115	155	195	275	275
SER12A	SERS12A	120	170	220	270	320	370	470	470
SER15A	SERS15A	150	230	310	430	550	670		670
SER20A	SERS20A	220	280	340	460	640	880		880

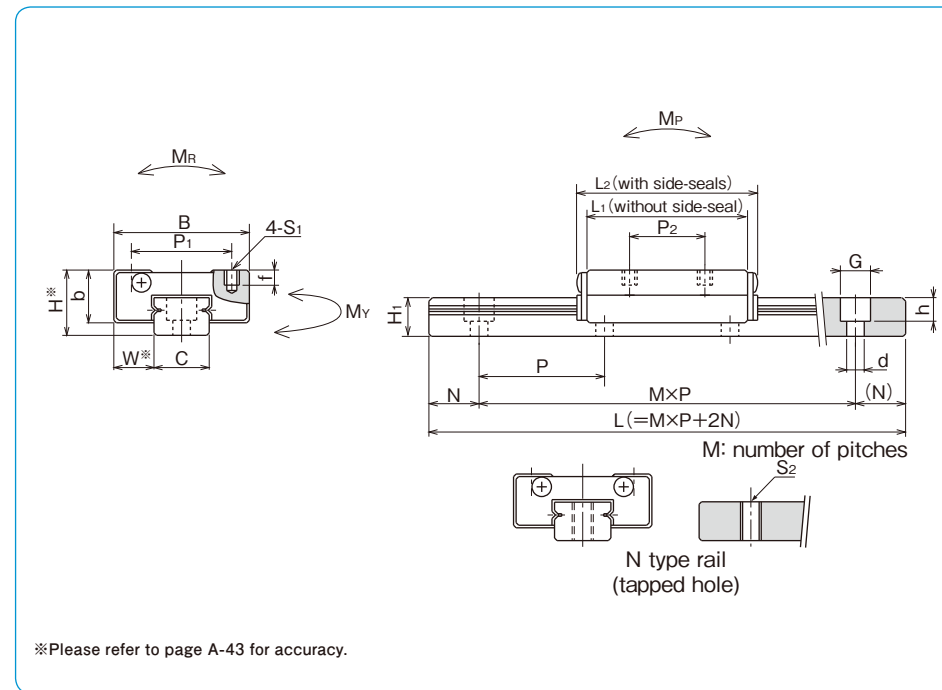

guide rail dimensions		basic load rating		allowable static moment			mass		block size				
H ₁	C	S ₂	d×G×h	N	P	C _d	C _o	M _P	M _Y	M _R	block	guide rail	block size
mm	mm		mm	mm	mm	kN	kN	N·m	N·m	N·m	g	g/100mm	
5.5	8.6	M4	2.6×4.5×3	7.5	20	2.65	2.94	11.8	13.7	19.6	25	35	9A
7.5	11			10	25	3.43	3.92	15.7	17.6	29.4	51	55	12A
9.5	15	M5	3.5×6×4.5	15	40	4.70	5.78	29.0	32.3	54.9	82	100	15A
15	20			20	60	8.82	9.80	59.0	66.6	151	280	230	20A

1kN≒102kgf 1N·m≒0.102kgf·m

SER-WA TYPE

– Wide Type –

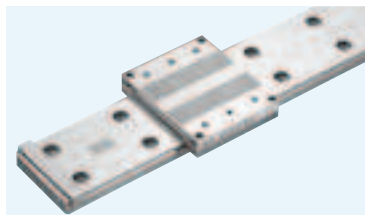

part number structure

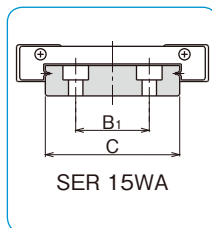
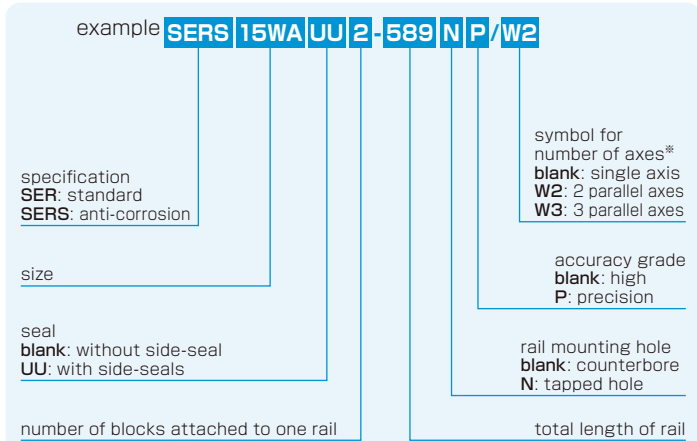

* The symbol for the number of axes does not mean the number of rails ordered.

part number		assembly dimensions		block dimensions							f	b
standard	anti-corrosion	H	W	B	L ₁	L ₂	P ₁	P ₂	S ₁			
		mm	mm	mm	mm	mm	mm	mm	mm	mm		
SER 9WA	SERS 9WA	12	6.5	30	35	39	21	10	M3	3	8.8	
SER12WA	SERS12WA	14	9	40	40	44	28	12.5			11	
SER15WA	SERS15WA	16		60	50	54	45	15			M4	4.5

part number		standard rail length							maximum length
standard	anti-corrosion	L							
		mm							mm
SER 9WA	SERS 9WA	80	110	140	170	200	260	290	290
SER12WA	SERS12WA	110	150	190	230	310	390	470	470
SER15WA	SERS15WA	150	230	310	430	550	670		670

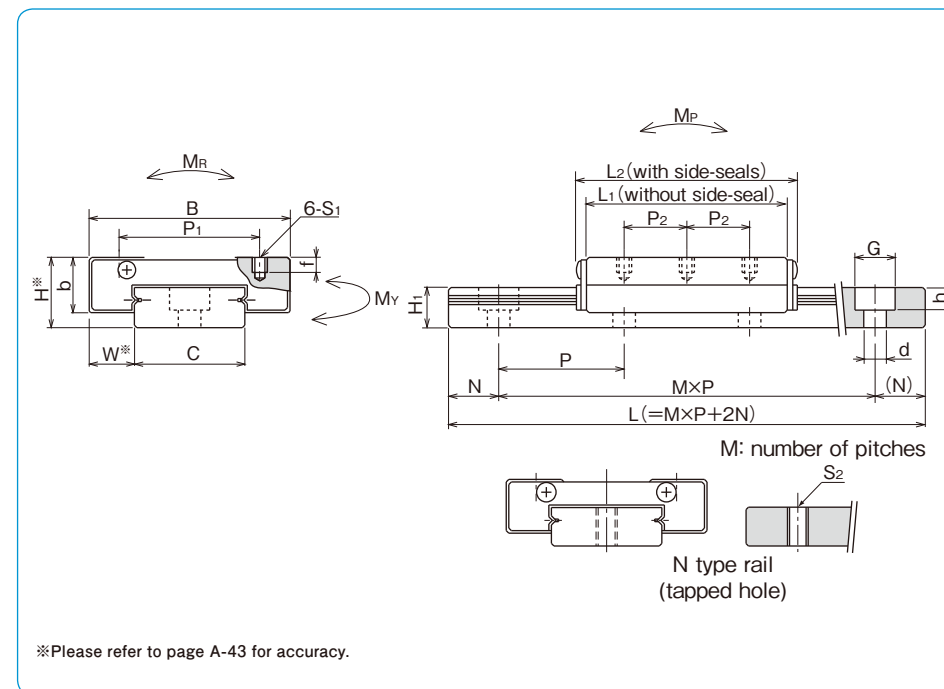

guide rail dimensions		basic load rating		allowable static moment			mass		block size		
H ₁	C	dynamic	static	M _P	M _Y	M _R	block	guide rail			
mm	mm	C	Co	N · m	N · m	N · m	g	g/100mm			
7.5	17	—	M4	3.43	3.72	24.5	27.4	51.9	46	90	9WA
8	22	—	M5	4.41	5.00	35.3	39.2	85.3	92	122	12WA
9.5	42	23		7.35	8.92	55.9	61.7	215.0	165	280	15WA

1kN ≒ 102kgf 1N · m ≒ 0.102kgf · m

SLIDE GUIDE SGL TYPE

The NB slide guide SGL type is a linear motion bearing utilizing the rotational motion of ball elements along four rows of raceway grooves. It can be used in various applications due to its compactness and high load capacity.

STRUCTURE AND ADVANTAGES

The NB slide guide SGL type consists of a rail with 4 rows of precisely machined raceway grooves and a block assembly. The block assembly consists of the main body, ball elements, retainers, and return caps.

High Load Capacity and Long Life

The use of relatively large ball elements and raceway grooves machined to a radius close to that of the ball elements increases the contact area resulting in a high load capacity and a long travel life.

Low Friction

Because a 4-row/2-point contact design is used, low friction and stable motion characteristics are achieved even under a preloaded conditions.

Omni-Directional Load Capacity

The ball elements are positioned at 45° contact angle so that the load capacity is equal in four directions (above, below, right and left).

Absorption of Mounting Dimensional Error

Because the ball elements are positioned to increase their self-aligning characteristics, the dimensional error caused during installation is absorbed.

Anti-corrosion Specification

The rail and block assembly can be treated with low temperature black chrome treatment to increase the

corrosion resistance. This treatment is standardized with the symbol "LB". Stainless steel SGLS type is suitable for use in clean room application.

Dust Prevention

Side-seals are provided as a standard. To improve the dust prevention characteristics, under-seals, double-seals, scrapers, bellows and special rail mounting caps are also available.

Fiber Sheet Extends Lubricant Replenishment Intervals

A lubricant-containing Fiber Sheet incorporated in the block supplies appropriate amount of lubricant to the raceway grooves at appropriate intervals, which can significantly extend the lubricant replenishment interval. (refer to page A-16)

REVERSE-SEAL

NB Reverse-seal realizes maintenance free by reducing grease leakage and loss. (refer to page A-17)

Figure A-54 Structure of SGL type Slide Guide

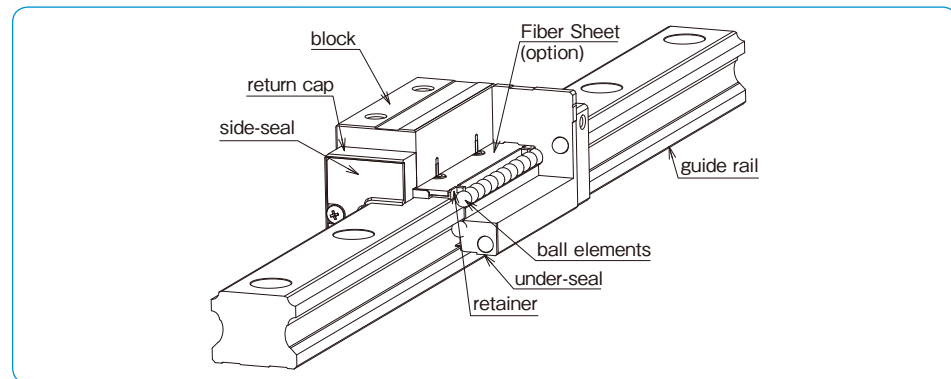

BLOCK TYPES

Nine SGL block types are available depending on the material and mounting method.

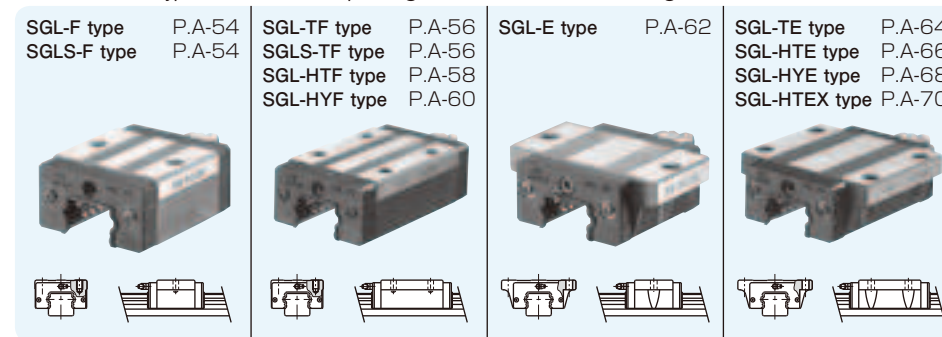

ACCURACY

Three accuracy grades are available: standard grade (blank), high grade (H), and precision grade (P).

Table A-23 Accuracy

part number	SGL15,20			SGL25,30,35			SGL45		
	standard	high	precision	standard	high	precision	standard	high	precision
accuracy grade	blank	H	P	blank	H	P	blank	H	P
accuracy symbol	blank	H	P	blank	H	P	blank	H	P
allowable dimensional tolerance for height H	±0.1	±0.03	-0.03~0	±0.1	±0.04	-0.04~0	±0.1	±0.05	-0.05~0
paired difference for height H	0.02	0.01	0.006	0.02	0.015	0.007	0.03	0.015	0.007
allowable dimensional tolerance for width W	±0.1	±0.03	-0.03~0	±0.1	±0.04	-0.04~0	±0.1	±0.05	-0.05~0
paired difference for width W	0.02	0.01	0.006	0.03	0.015	0.007	0.03	0.02	0.01
Running parallelism of surface C to surface A	refer to Figure A-55, 56								
Running parallelism of surface D to surface B	refer to Figure A-55, 56								

Figure A-55 Motion Accuracy

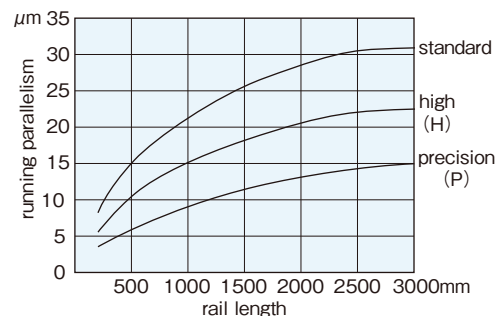
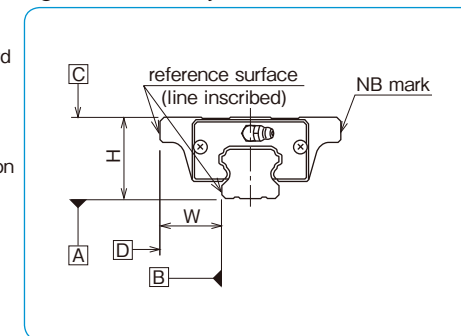

Figure A-56 Accuracy



PRELOAD

SGL type slide guides are available with a standard preload (blank), light preload (T1), and medium preload (T2).

Table A-24 Preload Symbol and Radial Clearance unit/μm

preload	standard	light	medium
preload symbol	blank	T1	T2
SGL15	- 4~+2	-12~- 4	-
SGL20	- 5~+2	-14~- 5	-23~-14
SGL25	- 6~+3	-16~- 6	-26~-16
SGL30	- 7~+4	-19~- 7	-31~-19
SGL35	- 8~+4	-22~- 8	-35~-22
SGL45	-10~+5	-25~-10	-40~-25

Table A-25 Operating Conditions and Preload

preload	symbol	operating conditions
standard	blank	minute vibration is applied. accurate motion is required. moment is applied in a given direction.
light	T1	light vibration is applied. light torsional load is applied. moment is applied.
medium	T2	shock and vibration are applied. over-hang load is applied. torsional load is applied.

RAIL LENGTH

Slide guides with most commonly used lengths are available as standard. For slide guides with a non-standard length, unless otherwise specified, the distance from one end of the rail to the first hole center (N) will be within the range listed in Table A-26, satisfying the following equation.

$$L = M \cdot P + 2N$$

L: length (mm) M: number of pitches P: hole pitch (mm)
N: distance from the end of the rail to the first hole center (mm)

Figure A-57 Rail

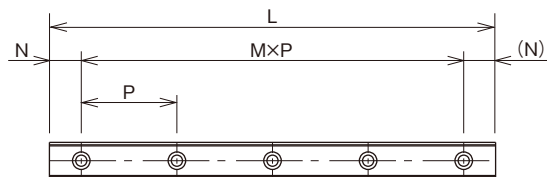

Table A-26 N Dimension unit/mm

part number	N		L max.
	and over	less than	
SGL15	6	36	2,000
SGL20	10	40	
SGL25	11	41	
SGL30	12	52	
SGL35	16	56	
SGL45	20	72.5	

MOUNTING

Slide guides are generally mounted by pushing the reference surface of the rail and block against the shoulder of the mounting surface. An escape groove should be provided at the corner of the shoulder in order to avoid interference with the corner of the rail or block. The recommended shoulder height values are shown in Table A-28.

The screws to fasten the rail should be tightened equally using a torque wrench in order to secure the motion accuracy. The recommended torque values are listed in Table A-27. Please adjust the torque depending on the operating conditions.

Table A-27 Recommended Torque unit/N·m

size	M3	M4	M5	M6	M8	M12
recommended torque	1.4	3.2	6.6	11.2	27.6	96.4

(for steel alloy screws)

Figure A-58 Mounting Reference Surface Profile

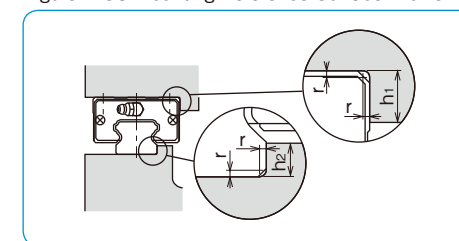

Table A-28 Shoulder Height Dimensions unit/mm

part number	h1	h2	r _{max.}
SGL15	4	3.5	0.5
SGL20	5	5	0.5
SGL25	5	5.5	1
SGL30	6	7.5	1
SGL35	6	8	1
SGL45	8	8	1

GREASE FITTING

A grease fitting is attached to the return cap of SGL type guide blocks for lubrication purposes. Unless otherwise specified, the orientation of the grease fitting is as shown in Figure A-59. When more than 2 blocks are used on one rail, please specify the grease fitting orientation.

Figure A-59 Grease Fitting Orientation

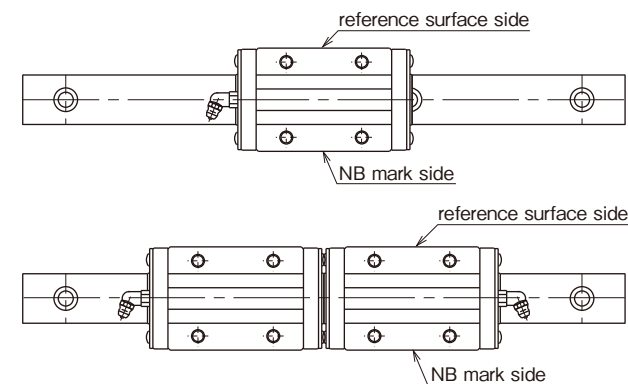

SGL-F TYPE

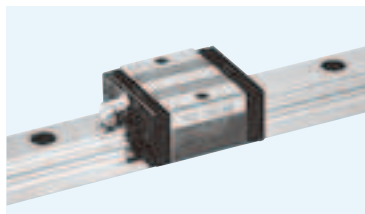

part number structure

example **SGL 15 F B 2 T1 - 589 D P / W2 FS LB F J - KGL**

specification	SGL	symbol for grease	KGL
SGL: standard	15	blank: standard grease	L
SGLS: anti-corrosion	F	KGL : lithium-based grease	G
size	B	KGU : urea-based grease	F
block style	2	KGF : anti-fretting grease	J
seal (refer to page A-14)	T1	GK : K-grease	-
blank: with side-seals	-	refer to page Eng-39~	
B : with side-seals + under-seals	589		
BW : with double-seals + under-seals	D		
BS : B + scraper	P	with bellows (refer to page A-18)	
BR : B + reverse-seals	/W2	with rail mounting hole caps	
number of blocks attached to one rail	FS	with low temperature black chrome treatment	
preload symbol	LB	with Fiber Sheet	
blank: standard	F	symbol for number of axes*	
T1 : light	J	blank: single axis	
T2 : medium	-	W2 : 2 parallel axes	
total length of rail	-	W3 : 3 parallel axes	
size of rail installation hole (D type rail is available only for SGL 15)	-	accuracy grade	
		blank: standard	
		H : high	
		P : precision	

*The symbol for the number of axes does not mean the number of rails ordered.

part number		assembly dimensions		block dimensions											
standard	anti-corrosion	H	W	B	L ₁	L ₂	L ₃	L ₄	L ₅	P ₁	S ₁	f	T	b	E ₁
		mm	mm	mm	mm	mm	mm	mm	mm	mm	mm	mm	mm	mm	mm
SGL15F	SGLS15F	24	9.5	34	40.7	22.7	46.9	47.3	54.3	26	M4	7	6	19.5	6
SGL15F-D	SGLS15F-D														
SGL20F	SGLS20F	28	11	42	47.9	29.5	54.1	54.5	65.5	32	M5	8	7.5	22	12
SGL25F	SGLS25F	33	12.5	48	58.7	37.7	65.1	65.9	76.9	35	M6	9	8	26	
SGL30F	—	42	16	60	68	40	76.6	75.6	—	40	M8	12	9	32.5	
SGL35F	—	48	18	70	77	46	85.6	84.6	—	50			13	38	

part number		standard rail length L														
standard	anti-corrosion	mm														
SGL15	SGLS15	160	220	280	340	400	460	520	580	640	700	760	820	880	940	1,000
SGL20	SGLS20	220	280	340	400	460	520	580	640	700	760	820	880	940	1,000	1,120
SGL25	SGLS25	220	280	340	400	460	520	580	640	700	760	820	880	940	1,000	1,120
SGL30	—	280	360	440	520	600	680	760	840	920	1,000	1,080	1,160	1,240	1,320	1,400
SGL35	—	280	360	440	520	600	680	760	840	920	1,000	1,080	1,160	1,240	1,320	1,400

Rails exceeding the maximum specified length may be fabricated if joints are used. Please contact NB for assistance.

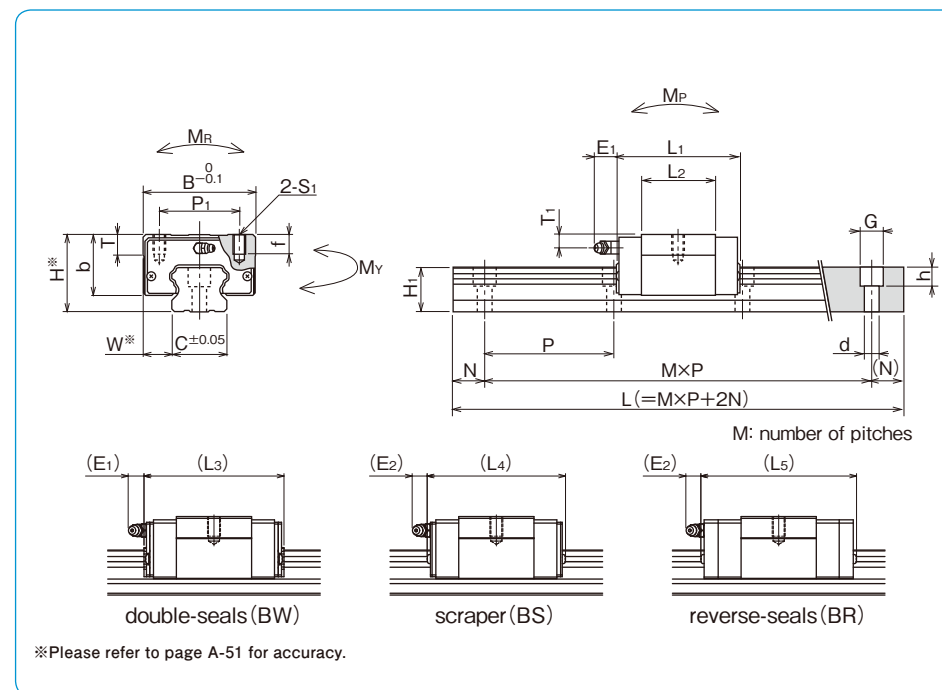

E ₂		T ₁	grease fitting	guide rail dimensions			basic load rating		allowable static moment			mass		block size	
mm	mm	mm	H ₁	C	d × G × h	N	P	dynamic C	static Co	M _{P2}	M _{Y2}	M _R	block kg	guide rail kg/m	
mm	mm	mm	mm	mm	mm	mm	mm	kN	kN	N · m	N · m	N · m	kg	kg/m	
5.4	5	pressed fitting	13.5	15	3.5 × 6 × 4.5	20	60	7.29	9.45	36.7	36.7	73.9	0.1	1.3	
					4.5 × 7.5 × 5.3					252	252				
11	6	B-M6F	16	20	6 × 9.5 × 8.5	20	80	11.9	14.8	71.9	71.9	159	0.2	2.1	
					7 × 11 × 9					447	447				
	6.5				20					23	123				123
	9				24					28	751				751
8.5	8.5	pressed fitting	27.5	34	9 × 14 × 12	20	80	23.0	28.7	195	195	417	0.5	4.6	
					1,260					1,260					
								32.0	37.8	293	293	693	0.8	6.2	
										1,870	1,870			35	

M_{P2} and M_{Y2} are allowable static moments when two blocks are used in close contact. 1kN ≒ 102kgf 1N · m ≒ 0.102kgf · m

				maximum length mm	
				standard	anti-corrosion
1,120	1,240	1,360	1,480	2,000	1,480
1,240	1,360	1,480	1,600	1,660	1,720
1,240	1,360	1,480	1,600	1,660	1,720
1,480	1,640	1,720	1,800	1,880	1,960
1,480	1,640	1,720	1,800	1,880	1,960

SGL-HTF TYPE

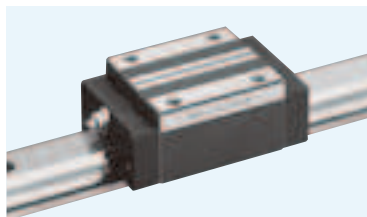

part number structure

example **SGL 15 HTF B 2 T1 - 589 P / W2 FS LB F J - KGL**

SGL type: **SGL**
 size: **15**
 block style: **HTF**
 seal (refer to page A-14): **B**
 number of blocks attached to one rail: **2**
 preload symbol: **T1**
 total length of rail: **589**
 symbol for grease: **P**
 with bellows (refer to page A-18): **W2**
 with rail mounting hole caps: **FS**
 with low temperature black chrome treatment: **LB**
 with Fiber Sheet: **F**
 symbol for number of axes*: **J**
 accuracy grade: **KGL**

blank: standard grease
 KGL: lithium-based grease
 KGU: urea-based grease
 KGF: anti-fretting grease
 GK: K-grease refer to page Eng-39~

blank: with side-seals
 B: with side-seals + under-seals
 BW: with double-seals + under-seals
 BS: B + scraper
 BR: B + reverse-seals

blank: single axis
 W2: 2 parallel axes
 W3: 3 parallel axes

blank: standard
 H: high
 P: precision

*The symbol for the number of axes does not mean the number of rails ordered.

part number	assembly dimensions		block dimensions													
	H	W	B	L1	L2	L3	L4	L5	P1	P2	S1	f	T	b	E1	E2
	mm	mm	mm	mm	mm	mm	mm	mm	mm	mm	mm	mm	mm	mm	mm	mm
SGL15HTF	28	9.5	34	56.5	38.5	62.7	63.1	70.1	26	26	M4	5	6	23.7	6	5.4
SGL20HTF	30	12	44	71.6	53.2	77.8	78.2	89.2	32	36	M5	6	9.5	24		
SGL25HTF	40	12.5	48	80	59	86.4	87.2	98.2	35	35	M6	8	9	33	12	11
SGL30HTF	45	16	60	95.7	67.7	104.3	103.3	—	40	40	M8	10	13	35.5		
SGL35HTF	55	18	70	109	78	117.6	116.6	—	50	50		12	15	45		
SGL45HTF	70	20.5	86	139	102	147.5	148	—	60	60	M10	17	15	60	15	15

part number	standard rail length L mm															
SGL15	160	220	280	340	400	460	520	580	640	700	760	820	880	940	1,000	1,120
SGL20	220	280	340	400	460	520	580	640	700	760	820	880	940	1,000	1,120	1,240
SGL25	220	280	340	400	460	520	580	640	700	760	820	880	940	1,000	1,120	1,240
SGL30	280	360	440	520	600	680	760	840	920	1,000	1,080	1,160	1,240	1,320	1,400	1,480
SGL35	280	360	440	520	600	680	760	840	920	1,000	1,080	1,160	1,240	1,320	1,400	1,480
SGL45	570	675	780	885	990	1,095	1,200	1,305	1,410	1,515	1,620	1,725	1,830	1,935	2,040	2,145

Rails exceeding the maximum specified length may be fabricated if joints are used. Please contact NB for assistance.

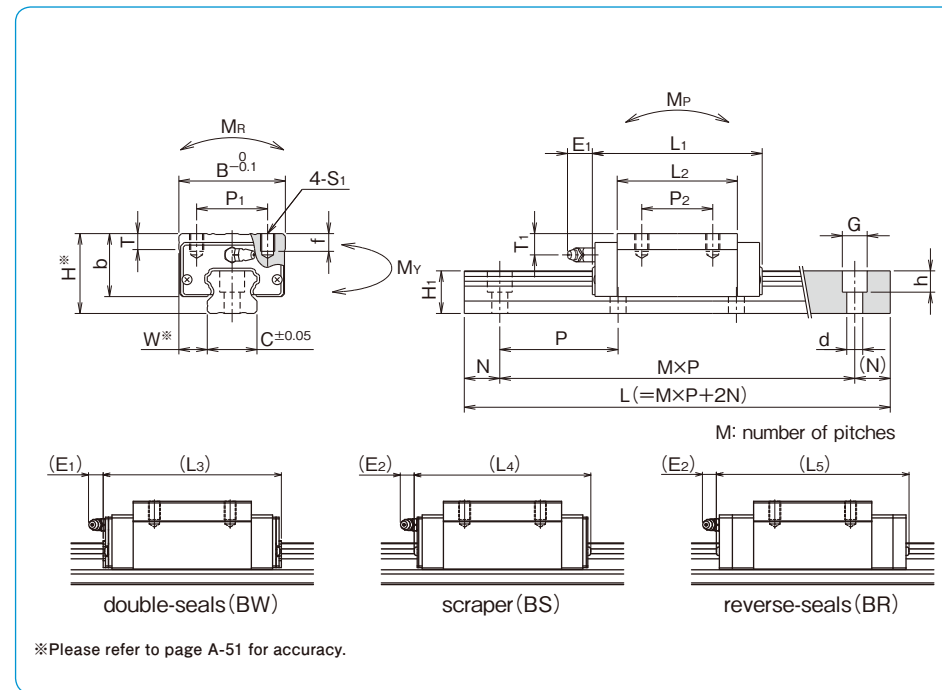

T1	grease fitting	guide rail dimensions				N	P	basic load rating			allowable static moment			mass		block size
		H1	C	d×G×h	dynamic C			static Co	MP	My	MR	block kg	guide rail kg/m			
mm		mm	mm	mm	kN	kN	N·m	N·m	N·m							
9	pressed fitting	13.5	15	4.5×7.5×5.3	10.6	16.2	99.5 565	99.5 565	126	0.2	1.3	15				
8	B-M6F	16	20	6×9.5×8.5	18.3	27.5	226 1,180	226 1,180	296	0.4	2.1	20				
13.5		20	23	7×11×9	24.7	36.3	334 1,740	334 1,740	437	0.6	3.0	25				
12		24	28	9×14×12	33.6	49.2	528 2,880	528 2,880	716	0.9	4.6	30				
15.5		27.5	34		46.6	64.8	796 4,290	796 4,290	1,180	1.5	6.2	35				
20	B-PT1/8	36.5	45	14×20×17	74.7	101	1,550 8,250	1,550 8,250	2,310	3.1	10.5	45				

MP2 and My2 are allowable static moments when two blocks are used in close contact. 1kN≒102kgf 1N·m≒0.102kgf·m

					maximum length mm
1,240	1,360	1,480			2,000
1,360	1,480	1,600	1,660	1,720 1,840 1,960	3,000
1,360	1,480	1,600	1,660	1,720 1,840 1,960	3,000
1,640	1,720	1,800	1,880	1,960	3,000
1,640	1,720	1,800	1,880	1,960	3,000
2,250	2,355	2,460	2,565	2,670 2,775 2,880 2,985	3,000

SGL-HYF TYPE

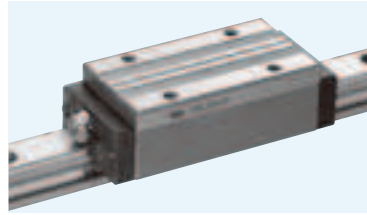

part number structure

example **SGL 15 HYF B 2 T1 -589 P/W2 FS LB F J -KGL**

- SGL type
- size
- block style
- seal (refer to page A-14)
 - blank: with side-seals
 - B: with side-seals + under-seals
 - BW: with double-seals + under-seals
 - BS: B + scraper
 - BR: B + reverse-seals
- number of blocks attached to one rail
- preload symbol
 - blank: standard
 - T1: light
 - T2: medium
- total length of rail
- symbol for grease
 - blank: standard grease
 - KGL: lithium-based grease
 - KGU: urea-based grease
 - KGF: anti-fretting grease
 - GK: K-grease refer to page Eng-39~
- with bellows (refer to page A-18)
- with rail mounting hole caps
- with low temperature black chrome treatment
- with Fiber Sheet
- symbol for number of axes*
 - blank: single axis
 - W2: 2 parallel axes
 - W3: 3 parallel axes
- accuracy grade
 - blank: standard
 - H: high
 - P: precision

*The symbol for the number of axes does not mean the number of rails ordered.

part number	assembly dimensions		block dimensions													
	H	W	B	L ₁	L ₂	L ₃	L ₄	L ₅	P ₁	P ₂	S ₁	f	T	b	E ₁	E ₂
	mm	mm	mm	mm	mm	mm	mm	mm	mm	mm	mm	mm	mm	mm	mm	mm
SGL15HYF	28	9.5	34	79	61	85.2	85.6	92.6	26	26	M4	5	6	23.7	6	5.4
SGL20HYF	30	12	44	96	77.6	102.2	102.6	113.6	32	50	M5	6	9.5	24	12	11
SGL25HYF	40	12.5	48	109	88	115.4	116.2	127.2	35		M6	8	9	33		
SGL30HYF	45	16	60	129	101	137.6	136.6	-	40	60	M8	10	13	35.5	12	11
SGL35HYF	55	18	70	147	116	155.6	154.6	-	50	72		12	13	45		
SGL45HYF	70	20.5	86	171	134	179.5	180	-	60	80	M10	17	15	60	15	15

part number	standard rail length L mm															
SGL 15	160	220	280	340	400	460	520	580	640	700	760	820	880	940	1,000	1,120
SGL20	220	280	340	400	460	520	580	640	700	760	820	880	940	1,000	1,120	1,240
SGL25	220	280	340	400	460	520	580	640	700	760	820	880	940	1,000	1,120	1,240
SGL30	280	360	440	520	600	680	760	840	920	1,000	1,080	1,160	1,240	1,320	1,400	1,480
SGL35	280	360	440	520	600	680	760	840	920	1,000	1,080	1,160	1,240	1,320	1,400	1,480
SGL45	570	675	780	885	990	1,095	1,200	1,305	1,410	1,515	1,620	1,725	1,830	1,935	2,040	2,145

Rails exceeding the maximum specified length may be fabricated if joints are used. Please contact NB for assistance.

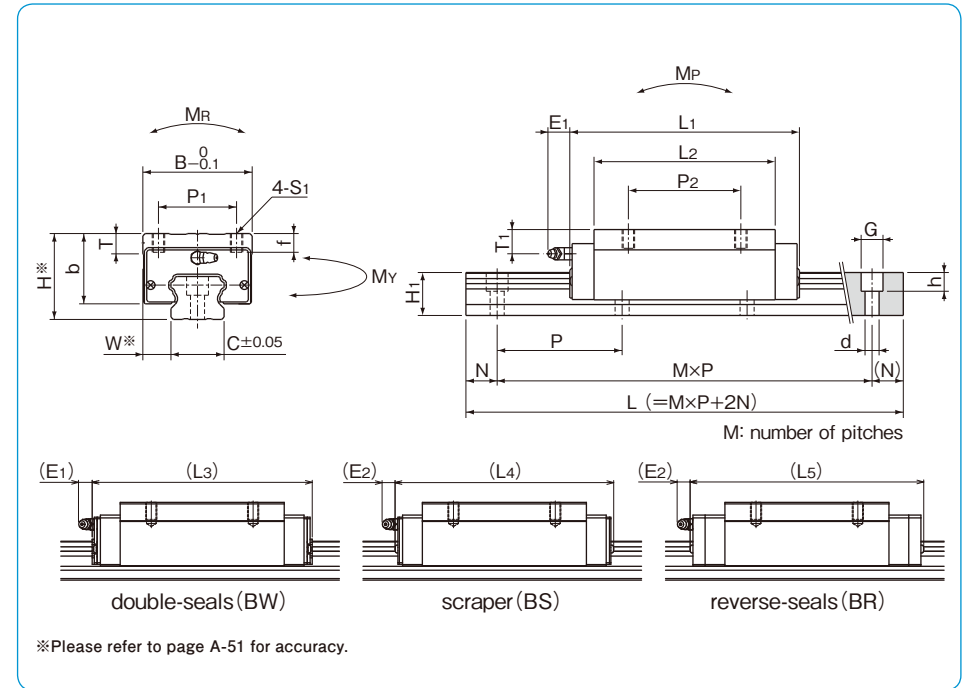

T ₁	grease fitting	guide rail dimensions				basic load rating		allowable static moment			mass		block size	
		H ₁	C	d × G × h	N	P	dynamic C	static C ₀	M _P	M _Y	M _R	block kg		guide rail kg/m
mm		mm	mm	mm	mm	mm	kN	kN	N · m	N · m	N · m	kg	kg/m	
9	pressed fitting	13.5	15	4.5 × 7.5 × 5.3	20	60	14.6	25.6	238	238	200	0.3	1.3	15
8	B-M6F	16	20	6 × 9.5 × 8.5			23.9	40.2	467	467	432	0.5	2.1	20
13.5		20	23	7 × 11 × 9	32.8	54.5	723	723	655	0.9	3.0	25		
12		24	28	9 × 14 × 12	44.6	73.8	1,140	1,140	1,070	1.3	4.6	30		
15.5		27.5	34		61.9	97.2	1,720	1,720	1,780	2.2	6.2	35		
20	B-PT1/8	36.5	45	14 × 20 × 17	22.5	105	91.4	134	2,680	2,680	3,080	4.0	10.5	45

M_{P2} and M_{Y2} are allowable static moments when two blocks are used in close contact. 1kN ≅ 102kgf 1N · m ≅ 0.102kgf · m

											maximum length
											mm
1,240	1,360	1,480									2,000
1,360	1,480	1,600	1,660	1,720	1,840	1,960					3,000
1,360	1,480	1,600	1,660	1,720	1,840	1,960					3,000
1,640	1,720	1,800	1,880	1,960							3,000
1,640	1,720	1,800	1,880	1,960							3,000
2,250	2,355	2,460	2,565	2,670	2,775	2,880	2,985				3,000

SGL-E TYPE

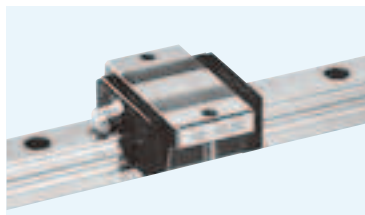

part number structure

example **SGL 15 E B 2 T1 - 589 D P / W2 FS LB F J - KGL**

<p>SGL type</p> <p>size</p> <p>block style</p> <p>seal (refer to page A-14)</p> <p>blank: with side-seals</p> <p>B: with side-seals + under-seals</p> <p>BW: with double-seals + under-seals</p> <p>BS: B + scraper</p> <p>BR: B + reverse-seals</p> <p>number of blocks attached to one rail</p> <p>preload symbol</p> <p>blank: standard</p> <p>T1: light</p> <p>T2: medium</p> <p>total length of rail</p> <p>size of rail installation hole (D type rail is available only for SGL 15)</p>	<p>symbol for grease</p> <p>blank: standard grease</p> <p>KGL: lithium-based grease</p> <p>KGU: urea-based grease</p> <p>KGF: anti-fretting grease</p> <p>KG: K-grease</p> <p>refer to page Eng-39~</p> <p>with bellows (refer to page A-18)</p> <p>with rail mounting hole caps</p> <p>with low temperature black chrome treatment</p> <p>with Fiber Sheet</p> <p>symbol for number of axes*</p> <p>blank: single axis</p> <p>W2: 2 parallel axes</p> <p>W3: 3 parallel axes</p> <p>accuracy grade</p> <p>blank: standard</p> <p>H: high</p> <p>P: precision</p>
--	---

*The symbol for the number of axes does not mean the number of rails ordered.

part number	assembly dimensions		block dimensions											
	H	W	B	L ₁	L ₂	L ₃	L ₄	L ₅	P ₁	S ₁	T	b	E ₁	E ₂
	mm	mm	mm	mm	mm	mm	mm	mm	mm	mm	mm	mm	mm	mm
SGL15E SGL15E-D	24	18.5	52	40.7	22.7	46.9	47.3	54.3	41	4.5	7	19.5	6	5.4
SGL20E	28	19.5	59	47.9	29.5	54.1	54.5	65.5	49	5.5	9	22	12	11
SGL25E	33	25	73	58.7	37.7	65.1	65.9	76.9	60	7	10	26		
SGL30E	42	31	90	68	40	76.6	75.6	—	72	9	32.5	38		
SGL35E	48	33	100	77	46	85.6	84.6	—	82		13	38		

part number	standard rail length L mm															
SGL15	160	220	280	340	400	460	520	580	640	700	760	820	880	940	1,000	1,120
SGL20	220	280	340	400	460	520	580	640	700	760	820	880	940	1,000	1,120	1,240
SGL25	220	280	340	400	460	520	580	640	700	760	820	880	940	1,000	1,120	1,240
SGL30	280	360	440	520	600	680	760	840	920	1,000	1,080	1,160	1,240	1,320	1,400	1,480
SGL35	280	360	440	520	600	680	760	840	920	1,000	1,080	1,160	1,240	1,320	1,400	1,480

Rails exceeding the maximum specified length may be fabricated if joints are used. Please contact NB for assistance.

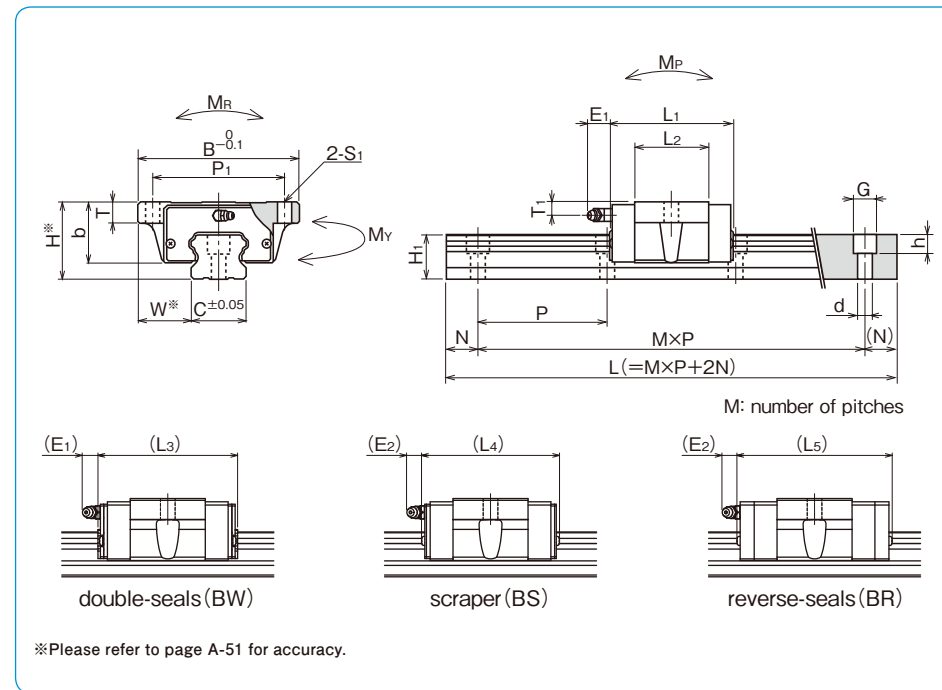

T ₁	grease fitting	guide rail dimensions				N	P	basic load rating		allowable static moment			mass		block size
		H ₁	C	d×G×h				dynamic C	static Co	M _P	M _Y	M _R	block	guide rail	
mm		mm	mm	mm		mm	mm	kN	kN	N·m	N·m	N·m	kg	kg/m	
5	pressed fitting	13.5	15	3.5×6×4.5		20	60	7.29	9.45	36.7	36.7	73.9	0.1	1.3	15
6		16	20	6×9.5×8.5				11.9	14.8	71.9	71.9	159	0.2	2.1	20
6.5	B-M6F	20	23	7×11×9		80	80	17.0	21.1	123	123	254	0.4	3.0	25
9		24	28					23.0	28.7	195	195	417	0.6	4.6	30
8.5		27.5	34					32.0	37.8	293	293	693	0.9	6.2	35
				9×14×12				32.0	37.8	293	293	693	0.9	6.2	35

M_{P2} and M_{Y2} are allowable static moments when two blocks are used in close contact. 1kN≒102kgf 1N·m≒0.102kgf·m

	maximum length mm
1,240 1,360 1,480	2,000
1,360 1,480 1,600 1,660 1,720 1,840 1,960	3,000
1,360 1,480 1,600 1,660 1,720 1,840 1,960	3,000
1,640 1,720 1,800 1,880 1,960	3,000
1,640 1,720 1,800 1,880 1,960	3,000

SGL-TE TYPE

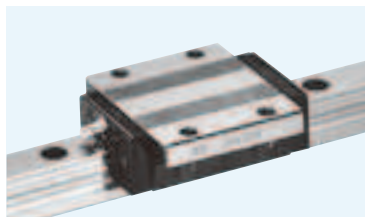

part number structure

example **SGL 15 TE B 2 T1 -589 D P /W2 FS LB F J -KGL**

<p>example SGL 15 TE B 2 T1 -589 D P /W2 FS LB F J -KGL</p> <p>SGL type</p> <p>size</p> <p>block style</p> <p>seal (refer to page A-14)</p> <p>blank: with side-seals</p> <p>B: with side-seals + under-seals</p> <p>BW: with double-seals + under-seals</p> <p>BS: B + scraper</p> <p>BR: B + reverse-seals</p> <p>number of blocks attached to one rail</p> <p>preload symbol</p> <p>blank: standard</p> <p>T1: light</p> <p>T2: medium</p> <p>total length of rail</p> <p>size of rail installation hole (D type rail is available only for SGL 15)</p>	<p>symbol for grease</p> <p>blank: standard grease</p> <p>KGL: lithium-based grease</p> <p>KGU: urea-based grease</p> <p>KGF: anti-fretting grease</p> <p>GK: K-grease</p> <p>refer to page Eng-39~</p> <p>with bellows (refer to page A-18)</p> <p>with rail mounting hole caps</p> <p>with low temperature black chrome treatment</p> <p>with Fiber Sheet</p> <p>symbol for number of axes*</p> <p>blank: single axis</p> <p>W2: 2 parallel axes</p> <p>W3: 3 parallel axes</p> <p>accuracy grade</p> <p>blank: standard</p> <p>H: high</p> <p>P: precision</p>
---	---

*The symbol for the number of axes does not mean the number of rails ordered.

part number	assembly dimensions		block dimensions												
	H	W	B	L ₁	L ₂	L ₃	L ₄	L ₅	P ₁	P ₂	S ₁	T	b	E ₁	E ₂
	mm	mm	mm	mm	mm	mm	mm	mm	mm	mm	mm	mm	mm	mm	mm
SGL15TE SGL15TE-D	24	18.5	52	56.5	38.5	62.7	63.1	70.1	41	26	4.5	7	19.5	6	5.4
SGL20TE	28	19.5	59	65.8	47.4	72	72.4	83.4	49	32	5.5	9	22		
SGL25TE	33	25	73	80	59	86.4	87.2	98.2	60	35	7	10	26	12	11
SGL30TE	42	31	90	95.7	67.7	104.3	103.3	-	72	40	9	10	32.5		
SGL35TE	48	33	100	109	78	117.6	116.6	-	82	50	9	13	38		

part number	standard rail length L mm															
SGL15	160	220	280	340	400	460	520	580	640	700	760	820	880	940	1,000	1,120
SGL20	220	280	340	400	460	520	580	640	700	760	820	880	940	1,000	1,120	1,240
SGL25	220	280	340	400	460	520	580	640	700	760	820	880	940	1,000	1,120	1,240
SGL30	280	360	440	520	600	680	760	840	920	1,000	1,080	1,160	1,240	1,320	1,400	1,480
SGL35	280	360	440	520	600	680	760	840	920	1,000	1,080	1,160	1,240	1,320	1,400	1,480

Rails exceeding the maximum specified length may be fabricated if joints are used. Please contact NB for assistance.

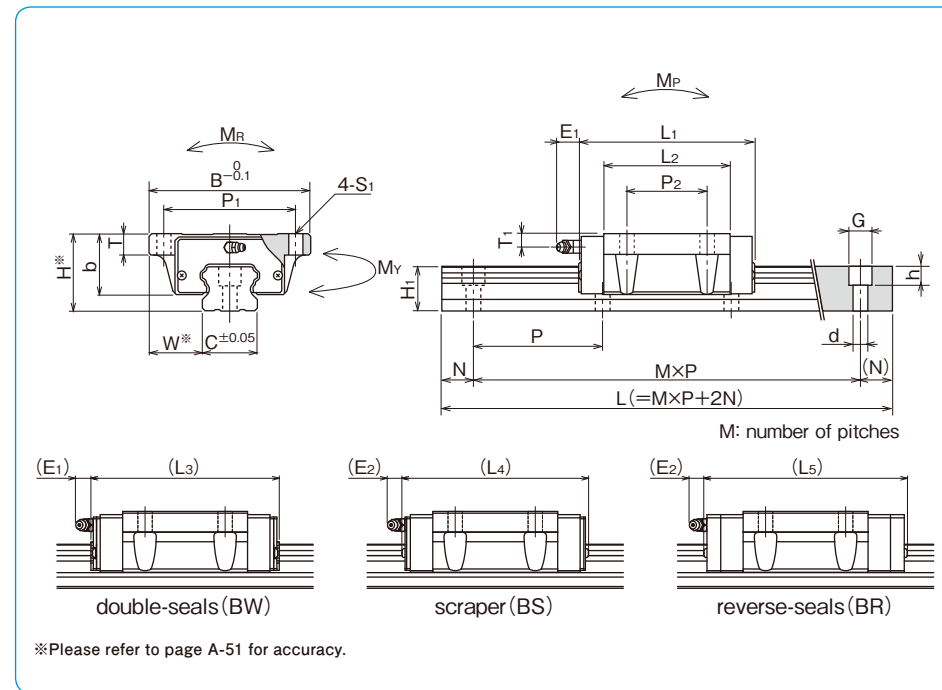

*Please refer to page A-51 for accuracy.

T ₁	grease fitting	guide rail dimensions				N	P	basic load rating			allowable static moment			mass block	mass guide rail	block size
		H ₁	C	d×G×h	N			dynamic C	static C ₀	M _P	M _Y	M _R	kg			
mm		mm	mm	mm	mm	mm	kN	kN	N·m	N·m	N·m					
5	pressed fitting	13.5	15	3.5×6×4.5 4.5×7.5×5.3			10.6	16.2	99.5 565	99.5 565	126	0.2	1.3	15		
6	B-M6F	16	20	6×9.5×8.5	20	60	16.3	23.2	165 897	165 897	250	0.3	2.1	20		
6.5		20	23	7×11×9			24.7	36.3	334 1,740	334 1,740	437	0.6	3.0	25		
9		24	28				33.6	49.2	528 2,880	528 2,880	716	1.0	4.6	30		
8.5		27.5	34	9×14×12			46.6	64.8	796 4,290	796 4,290	1,180	1.5	6.2	35		

M_P and M_Y are allowable static moments when two blocks are used in close contact. 1kN≒102kgf 1N·m≒0.102kgf·m

	maximum length mm
1,240 1,360 1,480	2,000
1,360 1,480 1,600 1,660 1,720 1,840 1,960	3,000
1,360 1,480 1,600 1,660 1,720 1,840 1,960	3,000
1,640 1,720 1,800 1,880 1,960	3,000
1,640 1,720 1,800 1,880 1,960	3,000

SGL-HYE TYPE

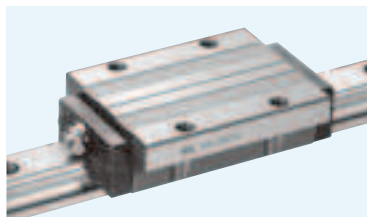

part number structure

example **SGL 15 HYE B 2 T1 - 589 P / W2 FS LB F J - KGL**

<p>example</p> <p>SGL type</p> <p>size</p> <p>block style</p> <p>seal (refer to page A-14)</p> <p>blank: with side-seals</p> <p>B: with side-seals + under-seals</p> <p>BW: with double-seals + under-seals</p> <p>BS: B + scraper</p> <p>BR: B + reverse-seals</p> <p>number of blocks attached to one rail</p> <p>preload symbol</p> <p>blank: standard</p> <p>T1: light</p> <p>T2: medium</p> <p>total length of rail</p>	<p>symbol for grease</p> <p>blank: standard grease</p> <p>KGL: lithium-based grease</p> <p>KGU: urea-based grease</p> <p>KGF: anti-fretting grease</p> <p>KG: K-grease</p> <p>refer to page Eng-39~</p> <p>with bellows (refer to page A-18)</p> <p>with rail mounting hole caps</p> <p>with low temperature black chrome treatment</p> <p>with Fiber Sheet</p> <p>symbol for number of axes*</p> <p>blank: single axis</p> <p>W2: 2 parallel axes</p> <p>W3: 3 parallel axes</p> <p>accuracy grade</p> <p>blank: standard</p> <p>H: high</p> <p>P: precision</p>
--	---

*The symbol for the number of axes does not mean the number of rails ordered.

part number	assembly dimensions		block dimensions													
	H	W	B	L1	L2	L3	L4	L5	P1	P2	S1	D	T	b	E1	E2
	mm	mm	mm	mm	mm	mm	mm	mm	mm	mm	mm	mm	mm	mm	mm	mm
SGL15HYE	24	16	47	79	61	85.2	85.6	92.6	38	30	M5	4.4	7.5	19.7	6	5.4
SGL20HYE	30	21.5	63	96	77.6	102.2	102.6	113.6	53	40	M6	5.4	10.5	24	12	11
SGL25HYE	36	23.5	70	109	88	115.4	116.2	127.2	57	45	M8	6.8	12.5	29		
SGL30HYE	42	31	90	129	101	137.6	136.6	-	72	52	M10	8.5	10	32.5		
SGL35HYE	48	33	100	147	116	155.6	154.6	-	82	62				13	38	
SGL45HYE	60	37.5	120	171	134	179.5	180	-	100	80	M12	10.5	15	50	15	15

part number	standard rail length L mm															
SGL 15	160	220	280	340	400	460	520	580	640	700	760	820	880	940	1,000	1,120
SGL20	220	280	340	400	460	520	580	640	700	760	820	880	940	1,000	1,120	1,240
SGL25	220	280	340	400	460	520	580	640	700	760	820	880	940	1,000	1,120	1,240
SGL30	280	360	440	520	600	680	760	840	920	1,000	1,080	1,160	1,240	1,320	1,400	1,480
SGL35	280	360	440	520	600	680	760	840	920	1,000	1,080	1,160	1,240	1,320	1,400	1,480
SGL45	570	675	780	885	990	1,095	1,200	1,305	1,410	1,515	1,620	1,725	1,830	1,935	2,040	2,145

Rails exceeding the maximum specified length may be fabricated if joints are used. Please contact NB for assistance.

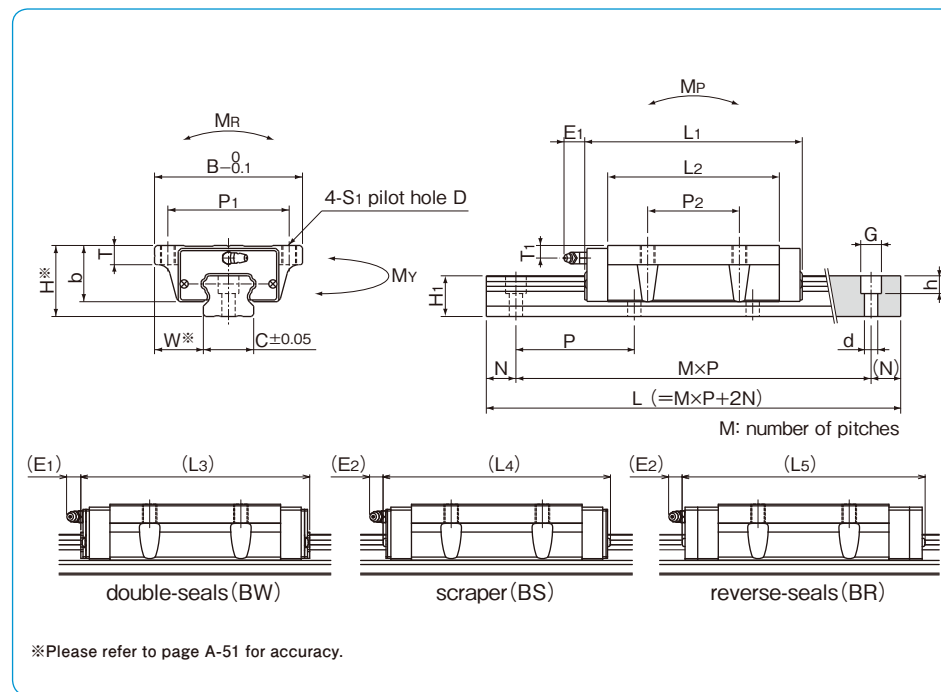

T1	grease fitting	guide rail dimensions				basic load rating		allowable static moment			mass		block size	
		H1	C	d×G×h	N	P	dynamic C	static Co	MP	My	MR	block		guide rail
mm		mm	mm	mm	mm	mm	kN	kN	N·m	N·m	N·m	kg	kg/m	
5	pressed fitting	13.5	15	4.5×7.5×5.3	20	60	14.6	25.6	238	238	200	0.3	1.3	15
8	B-M6F	16	20	6×9.5×8.5			23.9	40.2	467	467	432	0.7	2.1	20
9.5		20	23	7×11×9	32.8	54.5	723	723	655	1.0	3.0	25		
9		24	28	9×14×12	44.6	73.8	1,140	1,140	1,070	1.5	4.6	30		
8.5	27.5	34	61.9		97.2	1,720	1,720	1,780	2.2	6.2	35			
10	B-PT1/8	36.5	45	14×20×17	22.5	105	91.4	134	2,680	2,680	3,080	4.0	10.5	45

MP2 and My2 are allowable static moments when two blocks are used in close contact. 1kN≒102kgf 1N·m≒0.102kgf·m

											maximum length
											mm
1,240	1,360	1,480									2,000
1,360	1,480	1,600	1,660	1,720	1,840	1,960					3,000
1,360	1,480	1,600	1,660	1,720	1,840	1,960					3,000
1,640	1,720	1,800	1,880	1,960							3,000
1,640	1,720	1,800	1,880	1,960							3,000
2,250	2,355	2,460	2,565	2,670	2,775	2,880	2,985				3,000

SGL-HTEX TYPE

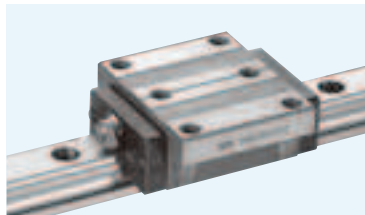

part number structure

example **SGL 15 HTEX B 2 T1 - 589 P / W2 FS LB F J - KGL**

SGL type: SGL
 size: 15
 block style: HTEX
 seal (refer to page A-14): B
 number of blocks attached to one rail: 2
 preload symbol: T1
 total length of rail: 589
 symbol for grease: KGL
 with bellows (refer to page A-18): FS
 with rail mounting hole caps: LB
 with low temperature black chrome treatment: F
 with Fiber Sheet: J
 symbol for number of axes*: J
 accuracy grade: K

blank: standard grease
 KGL: lithium-based grease
 KGU: urea-based grease
 KGF: anti-fretting grease
 GK: K-grease refer to page Eng-39~

blank: with side-seals
 B: with side-seals + under-seals
 BW: with double-seals + under-seals
 BS: B + scraper
 BR: B + reverse-seals

blank: with side-seals
 with rail mounting hole caps
 with low temperature black chrome treatment
 with Fiber Sheet

blank: single axis
 W2: 2 parallel axes
 W3: 3 parallel axes

blank: standard
 H: high
 P: precision

*The symbol for the number of axes does not mean the number of rails ordered.

part number	assembly dimensions		block dimensions															
	H	W	B	L ₁	L ₂	L ₃	L ₄	L ₅	P ₁	P ₂	S ₁	D	T	P ₃	S ₂	f	b	
	mm	mm	mm	mm	mm	mm	mm	mm	mm	mm	mm	mm	mm	mm	mm	mm	mm	mm
SGL15HTEX	24	16	47	56.5	38.5	62.7	63.1	70.1	38	30	M5	4.4	7.5	26	M5	6	19.7	
SGL20HTEX	30	21.5	63	71.6	53.2	77.8	78.2	89.2	53	40	M6	5.4	10.5	35	M6	8	24	
SGL25HTEX	36	23.5	70	80	59	86.4	87.2	98.2	57	45	M8	6.8	12.5	40	M8	10	29	
SGL30HTEX	42	31	90	95.7	67.7	104.3	103.3	-	72	52	M10	8.5	10	44	M10	13	32.5	
SGL35HTEX	48	33	100	109	78	117.6	116.6	-	82	62			13	52			38	
SGL45HTEX	60	37.5	120	139	102	147.5	148	-	100	80	M12	10.5	15	60	M12	14	50	

part number	standard rail length L mm															
SGL 15	160	220	280	340	400	460	520	580	640	700	760	820	880	940	1,000	1,120
SGL20	220	280	340	400	460	520	580	640	700	760	820	880	940	1,000	1,120	1,240
SGL25	220	280	340	400	460	520	580	640	700	760	820	880	940	1,000	1,120	1,240
SGL30	280	360	440	520	600	680	760	840	920	1,000	1,080	1,160	1,240	1,320	1,400	1,480
SGL35	280	360	440	520	600	680	760	840	920	1,000	1,080	1,160	1,240	1,320	1,400	1,480
SGL45	570	675	780	885	990	1,095	1,200	1,305	1,410	1,515	1,620	1,725	1,830	1,935	2,040	2,145

Rails exceeding the maximum specified length may be fabricated if joints are used. Please contact NB for assistance.

double-seals (BW) scraper (BS) reverse-seals (BR)

M: number of pitches

※Please refer to page A-51 for accuracy.

E ₁	E ₂	T ₁	grease fitting	guide rail dimensions				N	P	basic load rating dynamic C	static rating C ₀	allowable static moment			mass		block size			
				H ₁	C	d × G × h	M _P					M _Y	M _R	block kg	guide rail kg/m					
mm	mm	mm		mm	mm	mm	mm	mm	kN	kN	N · m	N · m	N · m	kg	kg/m					
6	5.4	5	pressed fitting	13.5	15	4.5 × 7.5 × 5.3	20	60	10.6	16.2	99.5	99.5	126	0.2	1.3	15				
											565	565	18.3	27.5	226	226	296	0.4	2.1	20
											1,180	1,180	24.7	36.3	334	334	437	0.6	3.0	25
											1,740	1,740	33.6	49.2	528	528	716	1.0	4.6	30
12	11	8	B-M6F	20	23	7 × 11 × 9	80	80	46.6	64.8	796	796	1,180	1.5	6.2	35				
											4,290	4,290	74.7	101	1,550	1,550	2,310	3.1	10.5	45
15	15	10	B-PT1/8	36.5	45	14 × 20 × 17	22.5	105	74.7	101	1,550	1,550	2,310	3.1	10.5	45				

M_{P2} and M_{Y2} are allowable static moments when two blocks are used in close contact. 1kN ≒ 102kgf 1N · m ≒ 0.102kgf · m

			maximum length mm
1,240	1,360	1,480	2,000
1,360	1,480	1,600	3,000
1,360	1,480	1,600	3,000
1,360	1,480	1,600	3,000
1,640	1,720	1,800	3,000
1,640	1,720	1,800	3,000
2,250	2,355	2,460	3,000

SLIDE GUIDE SGW Type

The NB slide guide SGW type is a linear motion bearing utilizing the rotational motion of ball elements along four rows of raceway grooves. Its low height and wide profile makes it suitable for single-rail applications.

STRUCTURE AND ADVANTAGES

The NB slide guide SGW type consists of a rail with four precisely machined raceway grooves and a block assembly. The block assembly consists of the main body, ball elements, retainers, and return caps.

High Load Capacity and Long Life

The raceway grooves are machined to a radius close to that of the ball elements. The larger contact area resulting in a high load capacity and a long travel life.

High Allowable Moment

Its wide profile enables it to sustain high moment loads, making it suitable for single-rail applications.

Omni-Directional Load Capacity

The ball elements are positioned at 45° contact angle so that the load capacity is equal in four directions (above, below, right and left).

Smooth Motion

The large number of effective ball elements produce a smooth rolling motion.

Anti-Corrosion Specification

The rail and block assembly can be treated with low temperature black chrome treatment to increase the corrosion resistance. This treatment is standardized with the symbol "LB", and suitable for use in clean room applications.

Dust Prevention

Side-seals are provided as standard. To improve the dust prevention characteristics, under-seals and rail mounting caps are also available.

Extension of Relubrication Period by Fiber Sheet

A lubricant-containing Fiber Sheet incorporated in the block supplies appropriate amount of lubricant to the raceway grooves, which significantly extends the lubricant replenishment interval. (refer to page A-16)

Figure A-60 Structure of SGW type Slide Guide

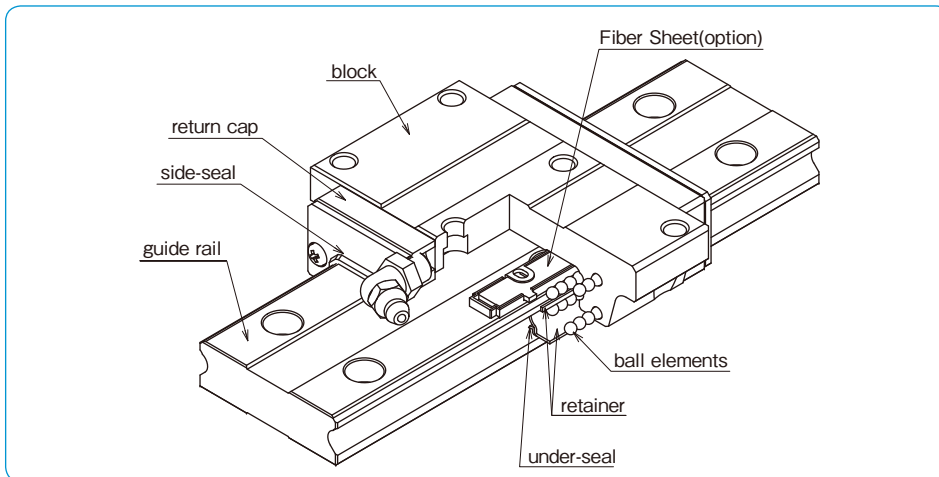

BLOCK TYPES

Two SGW block types are available depending on the mounting space and desired mounting method.

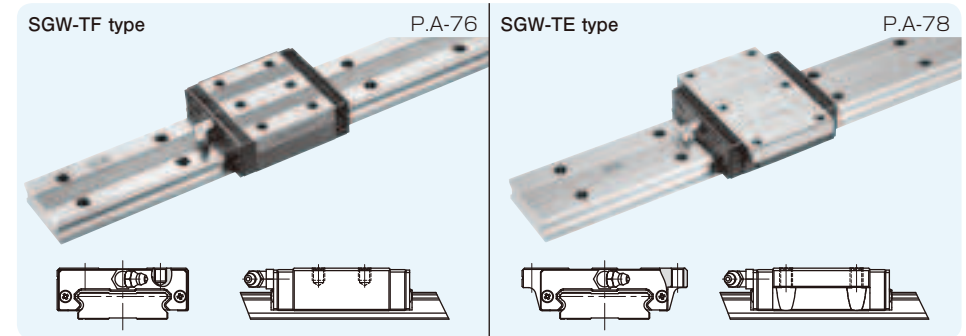

ACCURACY

Three accuracy grades are available: standard grade (blank), high grade (H), and precision grade (P).

Table A-29 Accuracy

part number	SGW17,21			SGW27,35		
	standard	high	precision	standard	high	precision
accuracy grade	blank	H	P	blank	H	P
accuracy symbol	blank	H	P	blank	H	P
allowable dimensional tolerance for height H	±0.1	±0.03	-0.03~0	±0.1	±0.04	-0.04~0
paired difference for height H	0.02	0.01	0.006	0.02	0.015	0.007
allowable dimensional tolerance for width W	±0.1	±0.03	-0.03~0	±0.1	±0.04	-0.04~0
paired difference for width W	0.02	0.01	0.006	0.03	0.015	0.007
Running parallelism of surface C to surface A	refer to Figure A-61,62					
Running parallelism of surface D to surface B	refer to Figure A-61,62					

Figure A-61 Motion Accuracy

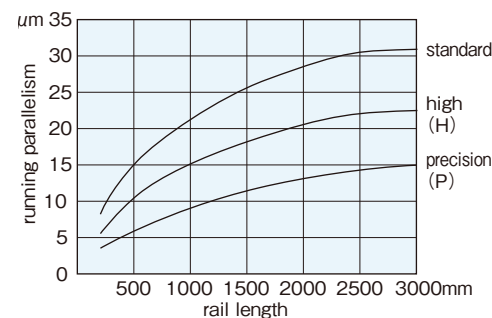
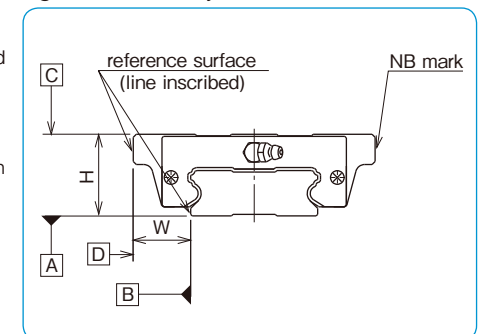

Figure A-62 Accuracy



PRELOAD

Three levels of preload are available for SGW slide guides: standard (blank), light (T1), and medium (T2).

Table A-30 Preload Call Out and Radial Clearance unit/ μm

preload	standard	light	medium
symbol	blank	T1	T2
SGW17	-3~+2	-7~-3	-
SGW21	-4~+2	-8~-4	-
SGW27	-5~+2	-11~-5	-
SGW35	-8~+4	-18~-8	-28~-18

Table A-31 Operating Conditions and Preload

preload	symbol	operating conditions
standard	blank	minute vibration is applied. accurate motion is required. moment is applied in a given direction.
light	T1	light vibration is applied. light torsional load is applied. moment is applied.
medium	T2	shock and vibration are applied. over-hang load is applied. torsional load is applied.

RAIL LENGTH

Slide guides with most commonly used lengths are available as standard. For slide guides with a non-standard length, unless otherwise specified, the distance from one end of the rail to the first hole center (N) will be within the range listed in Table A-32, satisfying the following equation.

$$L = M \cdot P + 2N$$

L: length (mm) M: number of pitches P: hole pitch (mm)
N: distance from the end of the rail to the first hole center (mm)

Table A-32 N Dimension unit/mm

part number	N		L max.
	and over	less than	
SGW17	8	28	2,000
SGW21		33	
SGW27		38	
SGW35	12	52	3,000

Figure A-63 Rail

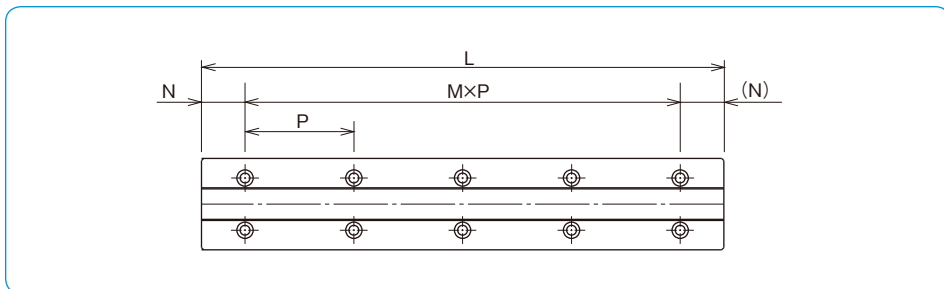

MOUNTING

Slide guides are generally mounted by pushing the reference surface of the rail and block against the shoulder of the mounting surface. To avoid interference between the shoulder and the corner of the rail or block, the recommended dimensions are listed in Table A-34.

The screws to fasten the rail should be tightened to an equal torque using a torque wrench in order to secure the motion accuracy. The recommended torque values are given in Table A-33. Please adjust the torque depending on the operating conditions.

Table A-33 Recommended Torque unit/ $\text{N} \cdot \text{m}$

size	M4	M6
recommended torque	3.2	11.2

(for alloy steel screw)

Figure A-64 Mounting Reference Surface Profile

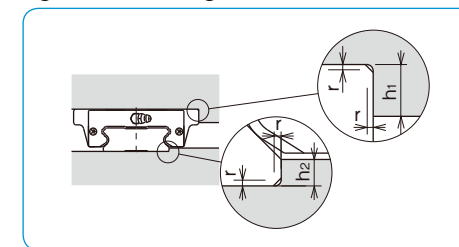

Table A-34 Shoulder Height and Radius Dimensions unit/mm

part number	h1	h2	rmax.
SGW17	4	2	0.4
SGW21	5	2.5	
SGW27		3.5	
SGW35		3.5	0.8

GREASE FITTING

A grease fitting is attached to the return cap of SGW type guide block for lubrication purposes. Unless otherwise specified, the orientation of the grease fitting is as shown in Figure A-65. When more than 2 blocks are used on one rail, please specify the grease fitting orientation.

Figure A-65 Grease Fitting Orientation

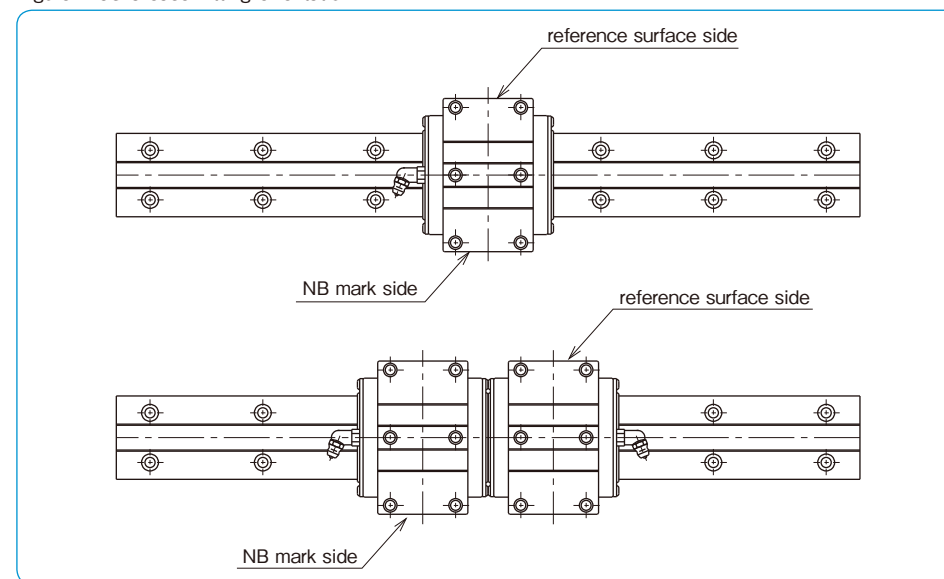

SGW-TF TYPE

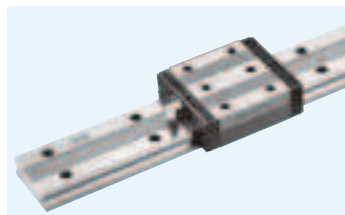

part number structure

example **SGW|21|TF|B|2|T1|-589|P|W2|FS|LB|F|-KGL**

<p>SGW type</p> <p>size</p> <p>TF typeblock</p> <p>seal (refer to page A-14)</p> <p>blank: with side-seals</p> <p>B: with side-seals + under-seals</p> <p>number of blocks attached to one rail</p> <p>preload symbol</p> <p>blank: standard</p> <p>T1: light</p> <p>T2: medium</p> <p>total length of rail</p> <p>accuracy grade</p> <p>blank: standard</p> <p>H: high</p> <p>P: precision</p>	<p>symbol for grease</p> <p>blank: standard grease</p> <p>KGL: lithium-based grease</p> <p>KGU: urea-based grease</p> <p>KGF: anti-fretting grease</p> <p>GK: K-grease</p> <p>refer to page Eng-39~</p> <p>with rail mounting hole caps</p> <p>with low temperature black chrome treatment</p> <p>with Fiber Sheet</p> <p>symbol for number of axes*</p> <p>blank: single axis</p> <p>W2: 2 parallel axes</p> <p>W3: 3 parallel axes</p>
---	--

*The symbol for the number of axes does not mean the number of rails ordered.

part number	assembly dimensions		block dimensions											grease fitting
	H	W	B	L ₁	L ₂	P ₁	P ₂	S	f	T	b	E	T ₁	
	mm	mm	mm	mm	mm	mm	mm	mm	mm	mm	mm	mm	mm	
SGW17TF	17	8.5	50	51	33.6	29	15	M4	4	—	14.5	2.5	4	pressed fitting
SGW21TF	21	8.5	54	58	40	31	19	M5	5	—	18	12	4.5	B-M6F
SGW27TF	27	10	62	71.8	51.8	46	32	M6	6	10	24		6	
SGW35TF	35	15.5	100	106.6	77.6	76	50	M8	8	14	31		8	

part number	standard rail length L mm										
SGW17	110	150	190	230	270	310	350	390	430	510	590
SGW21	130	180	230	280	330	380	430	480	530	630	730
SGW27	160	220	280	340	400	460	520	640	760	880	1,000
SGW35	280	360	440	520	600	680	760	920	1,080	1,240	1,400

Rails exceeding the maximum specified length may be fabricated if joints are used. Please contact NB for assistance.

SGW17·21TF

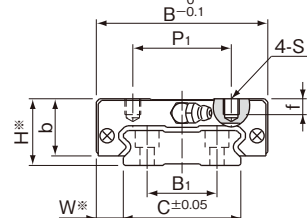

SGW27·35TF

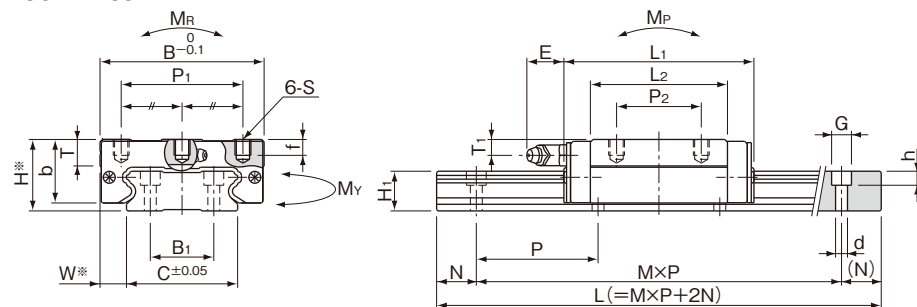

*Please refer to page A-73 for accuracy.

M: number of pitches

H ₁	C	B ₁	guide rail dimensions d×G×h	N	P	basic load rating			allowable static moment			mass block kg	mass guide rail kg/m	block size
						dynamic C kN	static C ₀ kN	M _{P2} N·m	M _{Y2} N·m	M _R N·m				
mm	mm	mm	mm	mm	mm	kN	kN	N·m	N·m	N·m	kg	kg/m		
9	33	18	4.5×7.5×5.3	15	40	4.82	8.56	42.8 261	42.8 261	160	0.13	2.05	17	
11	37	22			50	7.01	12.1	72.3 418	72.3 418	253	0.20	2.84	21	
15	42	24		20	60	12.9	21.5	171 931	171 931	496	0.38	4.43	27	
19	69	40			80	30.6	48.5	578 3,100	578 3,100	1,850	1.16	9.32	35	

M_{P2} and M_{Y2} are allowable static moments when two blocks are used in close contact. 1kN≒102kgf 1N·m≒0.102kgf·m

							maximum length mm
670	750	830	950	1,070	1,190	1,310	2,000
830	930	1,030	1,180	1,330	1,480		2,000
1,180	1,360	1,540	1,720	1,900			3,000
1,640	1,880	2,120					3,000

SGW-TE TYPE

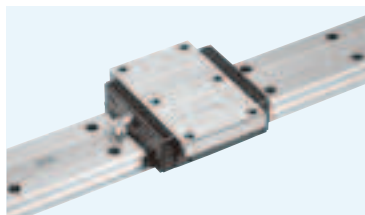

part number structure

example **SGW 21 TE B 2 T1 - 589 P / W2 FS LB F - KGL**

SGW type	size	TE typeblock	seal (refer to page A-14) blank: with side-seals B: with side-seals + under-seals	number of blocks attached to one rail	preload symbol blank: standard T1: light T2: medium	total length of rail	accuracy grade blank: standard H: high P: precision	symbol for grease blank: standard grease KGL: lithium-based grease KGU: urea-based grease KGF: anti-fretting grease GK: K-grease refer to page Eng-39~	with rail mounting hole caps	with low temperature black chrome treatment	with Fiber Sheet	symbol for number of axes* blank: single axis W2: 2 parallel axes W3: 3 parallel axes
----------	------	--------------	---	---------------------------------------	--	----------------------	--	--	------------------------------	---	------------------	--

*The symbol for the number of axes does not mean the number of rails ordered.

part number	assembly dimensions		block dimensions											grease fitting	
	H	W	B	L ₁	L ₂	P ₁	P ₂	S	D	F	T	b	E		T ₁
	mm	mm	mm	mm	mm	mm	mm	mm	mm	mm	mm	mm	mm	mm	mm
SGW17TE	17	13.5	60	51	33.6	53	26	M4	3.3	3.2	6	14.5	2.5	4	pressed fitting
SGW21TE	21	15.5	68	58	40	60	29	M5	4.4	3.7	8	18	12	4.5	B-M6F
SGW27TE	27	19	80	71.8	51.8	70	40	M6	5.3	6	10	24		6	
SGW35TE	35	25.5	120	106.6	77.6	107	60	M8	6.8	8	14	31		8	

part number	standard rail length L mm										
SGW17	110	150	190	230	270	310	350	390	430	510	590
SGW21	130	180	230	280	330	380	430	480	530	630	730
SGW27	160	220	280	340	400	460	520	640	760	880	1,000
SGW35	280	360	440	520	600	680	760	920	1,080	1,240	1,400

Rails exceeding the maximum specified length may be fabricated if joints are used. Please contact NB for assistance.

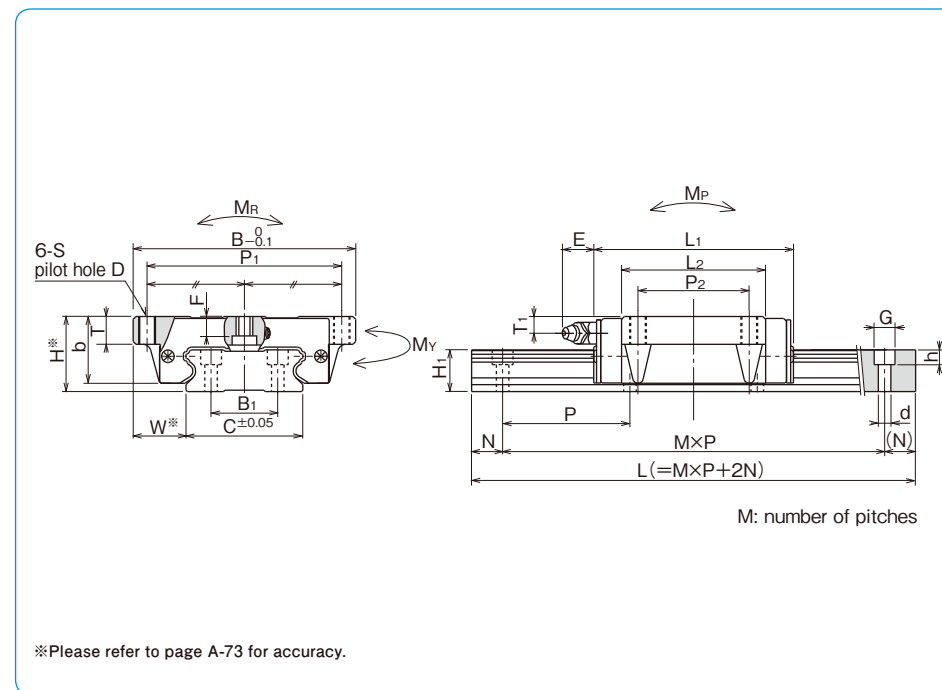

H ₁	C	B ₁	guide rail dimensions		N	P	basic load rating		allowable static moment			mass		block size
			d × G × h	d × G × h			dynamic C	static Co	M _P	M _Y	M _R	block	guide rail	
mm	mm	mm	mm	mm	mm	mm	kN	kN	N · m	N · m	N · m	kg	kg/m	
9	33	18	4.5 × 7.5 × 5.3	mm	15	40	4.82	8.56	42.8 261	42.8 261	160	0.14	2.05	17
11	37	22				50	7.01	12.1	72.3 418	72.3 418	253	0.23	2.84	21
15	42	24			20	60	12.9	21.5	171 931	171 931	496	0.46	4.43	27
19	69	40	7 × 11 × 9	80		30.6	48.5	578 3,100	578 3,100	1,850	1.35	9.32	35	

M_{P2} and M_{Y2} are allowable static moments when two blocks are used in close contact. 1kN ≅ 102kgf 1N · m ≅ 0.102kgf · m

							maximum length mm
670	750	830	950	1,070	1,190	1,310	2,000
830	930	1,030	1,180	1,330	1,480		2,000
1,180	1,360	1,540	1,720	1,900			3,000
1,640	1,880	2,120					3,000