

# STROKE BUSH SLIDE ROTARY BUSH

# STROKE BUSH

The NB stroke bush is a linear and rotational motion mechanism utilizing the rotational motion of ball elements between an outer cylinder and a shaft. It is compact and can withstand high loading. The retainer is made of a light metal alloy with high wear resistance. Smooth motion is achieved under high-speed and high-acceleration conditions.

Although the linear motion is limited to a specific stroke length, the combined rotation and stroke motion is achieved with very little frictional resistance. The NB stroke bush can be conveniently used in a variety of applications.

## STRUCTURE AND ADVANTAGES

The retainer in the NB stroke bush positions the ball elements in a zigzag arrangement. The inner surface of the outer cylinder is finished by precision grinding, resulting in smooth motion of the ball elements. Each of the ball elements is held in a separate hole and smooth motion is achieved for both rotational motion and linear motion. The retainer moves half the length of the linear motion, therefore, the stroke length is limited to approximately twice the length the retainer can travel within the outer cylinder. The actual stroke should be limited to 80% of the maximum stroke as listed in the dimension tables.

### High Precision

High-carbon chromium bearing steel is used for the outer cylinder. It is heat treated and ground to achieve high rigidity and accuracy.

### Ease of Mounting and Replacement

The highly accurate fabrication of the NB stroke bush results in uniform dimensions, facilitating parts replacement and housing fabrication.

### Light Weight and Space Saving

The use of an aluminum alloy for the retainer and the thin-wall outer cylinder makes the NB stroke bush light weight and compact.

### Lubrication

One lubrication hole is provided on each oil groove of the outer cylinder, making it easy to lubricate the SR stroke bush.

Figure E-1 Structure of SR Stroke Bush

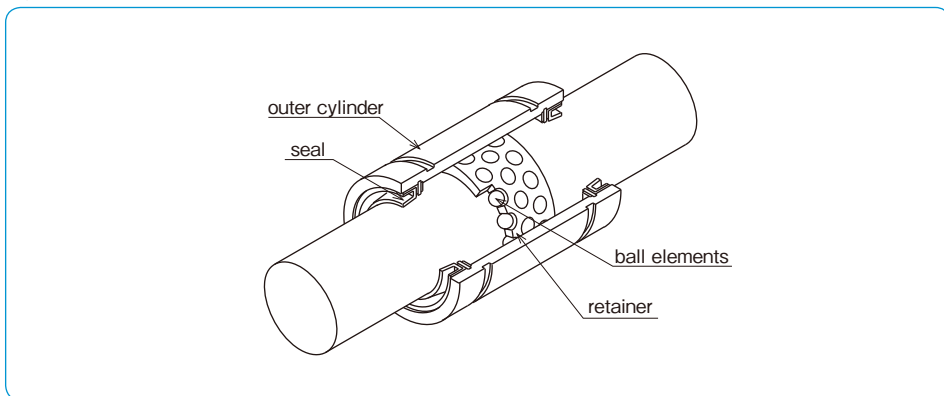

## ACCURACY

The accuracies of the SR stroke bush are stated in the dimension tables. Since the outer cylinder deforms due to tension from the retaining ring, the dimension of the outer cylinder is an average value at points P, where calculated using the following equation:

$$W=4+L/8$$

W: the distance from the end of the outer cylinder to measurement point P  
L: the length of the outer cylinder

## FIT

The fits generally used between the shaft and the housing are listed in Table E-1. The inner contact diameters of the SR stroke bush are listed in the dimension tables. The shaft diameter tolerance should be selected to achieve the desired amount of radial clearance (see Table E-2). Please pay attention that high-speed linear motion can cause the retainer to slip due to inertial force. In selecting a shaft, please take note of: Hardness: 58HRC or more (refer to hardness coefficient on page Eng-5) recommended Surface Roughness: less than 0.4Ra recommended

## RATED LOAD AND RATED LIFE

The relationship between the rated load and life of the stroke bush is expressed as follows:

$$L = \left( \frac{f_H \cdot f_T \cdot f_C \cdot C}{f_W \cdot P} \right)^3$$

L: rated life (10<sup>6</sup> rotations) f<sub>H</sub>: hardness coefficient  
f<sub>T</sub>: temperature coefficient f<sub>C</sub>: contact coefficient  
f<sub>W</sub>: applied load coefficient  
C: basic dynamic load rating (N)  
P: applied load (N)  
※Refer to page Eng-5 for the coefficients.

## ALLOWABLE SPEED FOR COMBINED ROTATION AND STROKE MOTION

The allowable speed for combined rotation and stroke motion is obtained from the following equation:

$$DN \geq dm \cdot n + 10 \cdot S \cdot n_1$$

Figure E-2 Outer Cylinder Measurement Points

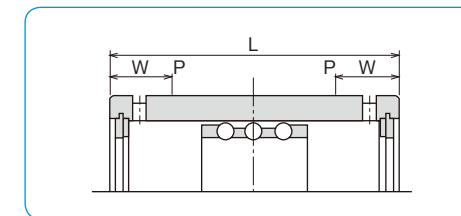

Table E-1

| normal operating condition |         | vertical use or highly accurate case |         |
|----------------------------|---------|--------------------------------------|---------|
| shaft                      | housing | shaft                                | housing |
| k5,m5                      | H6,H7   | n5,p6                                | J6,J7   |

Table E-2 Radial Clearance Negative Limit

| part number | limit (μm) |
|-------------|------------|
| 6           | - 2        |
| 8~10        | - 3        |
| 12~16       | - 4        |
| 20~30       | - 5        |
| 35~50       | - 6        |
| 60~80       | - 8        |
| 100         | -10        |

●For combined rotation and stroke motion

$$L_h = \frac{10^6 \cdot L}{60 \sqrt{(dm \cdot n)^2 + (10 \cdot S \cdot n_1)^2} / dm}$$

●For stroke motion

$$L_h = \frac{10^6 \cdot L}{600 \cdot S \cdot n_1 / (\pi \cdot dm)}$$

L<sub>h</sub>: life time (hr) S: stroke length (mm)  
n: revolutions per min. (rpm)  
n<sub>1</sub>: number of cycles per minute (cpm)  
dm: ball pitch diameter (mm) ≈ 1.15 dr

The value of DN is given as follows depending on the lubrication method.

|                        |            |
|------------------------|------------|
| for oil lubrication    | DN=600,000 |
| for grease lubrication | DN=300,000 |

note.....n≤5,000 S·n<sub>1</sub>≤50,000

# SR TYPE



## part number structure

example **SR 20**

SR type

inner contact diameter (dr)

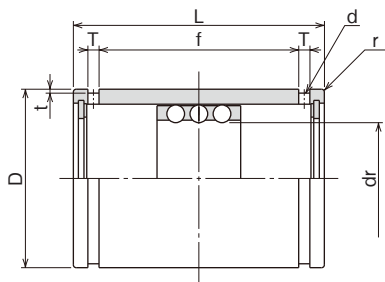

# SR-UU TYPE



## part number structure

example **SR 20 UU**

SR type

inner contact diameter (dr)

seals on both sides

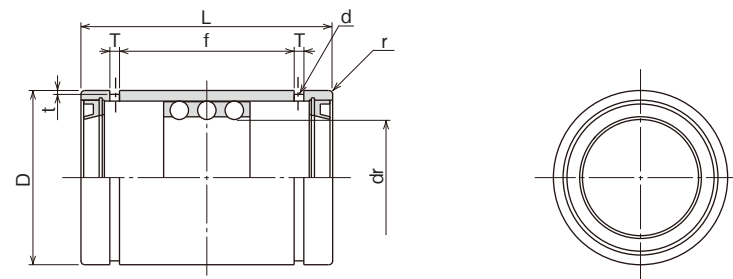

| part number | maximum stroke<br>mm | number of rows | dr<br>mm | major dimensions |         |                 |         |           |         |         |         | basic load rating |         |                   |                   |           |
|-------------|----------------------|----------------|----------|------------------|---------|-----------------|---------|-----------|---------|---------|---------|-------------------|---------|-------------------|-------------------|-----------|
|             |                      |                |          | tolerance<br>μm  | D<br>mm | tolerance<br>μm | L<br>mm | tolerance | f<br>mm | T<br>mm | t<br>mm | d<br>mm           | r<br>mm | dynamic<br>C<br>N | static<br>Co<br>N | mass<br>g |
| SR 6        | 19                   | 3              | 6        | +22              | 12      | 0               | 20      |           | 11.3    | 1.1     | 0.5     | 1                 | 0.5     | 216               | 147               | 8.9       |
| SR 8        | 24                   | 3              | 8        | +13              | 15      | -11             | 24      |           | 17.1    | 1.5     | 0.5     | 1.2               | 0.5     | 343               | 245               | 15.6      |
| SR 10       | 30                   | 3              | 10       | +17              | 19      | 0               | 30      | 0         | 22.7    | 1.5     | 0.5     | 1.2               | 0.5     | 637               | 461               | 28.8      |
| SR 12       | 32                   | 3              | 12       | +27              | 23      | -13             | 32      | -0.2      | 24.5    | 1.5     | 0.5     | 1.2               | 0.5     | 1,070             | 813               | 42        |
| SR 16       | 40                   | 3              | 16       | +16              | 28      |                 | 37      |           | 29.1    | 1.5     | 0.7     | 1.3               | 0.5     | 1,180             | 990               | 71        |
| SR 20       | 50                   | 3              | 20       | +33              | 32      | 0               | 45      |           | 35.8    | 2       | 0.7     | 1.5               | 0.5     | 1,260             | 1,170             | 99        |
| SR 25       | 50                   | 3              | 25       | +20              | 37      | -16             | 45      |           | 35.8    | 2       | 0.7     | 1.6               | 1       | 1,330             | 1,330             | 117       |
| SR 30       | 82                   | 3              | 30       |                  | 45      |                 | 65      |           | 53.5    | 2.5     | 1       | 2                 | 1       | 2,990             | 3,140             | 205       |
| SR 35       | 92                   | 3              | 35       |                  | 52      | 0               | 70      | 0         | 58.5    | 2.5     | 1       | 2                 | 1.5     | 3,140             | 3,530             | 329       |
| SR 40       | 108                  | 3              | 40       | +41              | 60      | 0               | 80      | -0.3      | 68.3    | 2.5     | 1       | 2                 | 1.5     | 4,120             | 4,800             | 516       |
| SR 50       | 138                  | 3              | 50       | +25              | 72      | -19             | 100     |           | 86.4    | 3       | 1       | 2.5               | 1.5     | 5,540             | 6,910             | 827       |
| SR 60       | 138                  | 3              | 60       | +49              | 85      | 0               | 100     |           | 86.4    | 3       | 1       | 2.5               | 2       | 5,980             | 8,230             | 1,240     |
| SR 80       | 132                  | 3              | 80       | +30              | 110     | -22             | 100     | 0         | 86      | 3       | 1.5     | 2.5               | 2       | 7,840             | 12,200            | 2,050     |
| SR100       | 132                  | 3              | 100      | +58/+36          | 130     | 0/-25           | 100     | -0.4      | 86      | 3       | 1.5     | 2.5               | 2       | 8,430             | 14,700            | 2,440     |

1N≅0.102kgf

| part number | maximum stroke<br>mm | number of rows | dr<br>mm | major dimensions |         |                 |         |           |         |         |         | basic load rating |         |                   |                   |           |
|-------------|----------------------|----------------|----------|------------------|---------|-----------------|---------|-----------|---------|---------|---------|-------------------|---------|-------------------|-------------------|-----------|
|             |                      |                |          | tolerance<br>μm  | D<br>mm | tolerance<br>μm | L<br>mm | tolerance | f<br>mm | T<br>mm | t<br>mm | d<br>mm           | r<br>mm | dynamic<br>C<br>N | static<br>Co<br>N | mass<br>g |
| SR 8UU      | 14                   | 3              | 8        | +22              | 15      | 0/-11           | 24      |           | 12.3    | 1.5     | 0.5     | 1.2               | 0.5     | 343               | 245               | 15.6      |
| SR 10UU     | 16                   | 3              | 10       | +13              | 19      | 0               | 30      | 0         | 17.1    | 1.5     | 0.5     | 1.2               | 0.5     | 637               | 461               | 28.8      |
| SR 12UU     | 18                   | 3              | 12       | +27              | 23      | -13             | 32      | -0.2      | 21.1    | 1.5     | 0.5     | 1.2               | 0.5     | 1,070             | 813               | 42        |
| SR 16UU     | 26                   | 3              | 16       | +16              | 28      |                 | 37      |           | 26.8    | 2       | 0.7     | 1.3               | 0.5     | 1,180             | 990               | 71        |
| SR 20UU     | 36                   | 3              | 20       |                  | 32      | 0               | 45      |           | 26.8    | 2       | 0.7     | 1.5               | 0.5     | 1,260             | 1,170             | 99        |
| SR 25UU     | 36                   | 3              | 25       | +33              | 37      | -16             | 45      |           | 26.8    | 2       | 0.7     | 1.6               | 1       | 1,330             | 1,330             | 117       |
| SR 30UU     | 68                   | 3              | 30       | +20              | 45      |                 | 65      |           | 45.1    | 2.5     | 1       | 2                 | 1       | 2,990             | 3,140             | 205       |
| SR 35UU     | 76                   | 3              | 35       |                  | 52      | 0               | 70      | 0         | 50.1    | 2.5     | 1       | 2                 | 1.5     | 3,140             | 3,530             | 329       |
| SR 40UU     | 91                   | 3              | 40       | +41              | 60      | 0               | 80      | -0.3      | 59.9    | 2.5     | 1       | 2                 | 1.5     | 4,120             | 4,800             | 516       |
| SR 50UU     | 116                  | 3              | 50       | +25              | 72      | -19             | 100     |           | 77.4    | 3       | 1       | 2.5               | 1.5     | 5,540             | 6,910             | 827       |
| SR 60UU     | 117                  | 3              | 60       | +49              | 85      | 0               | 100     |           | 77.4    | 3       | 1       | 2.5               | 2       | 5,980             | 8,230             | 1,240     |
| SR 80UU     | 110                  | 3              | 80       | +30              | 110     | -22             | 100     | 0         | 77      | 3       | 1.5     | 2.5               | 2       | 7,840             | 12,200            | 2,050     |
| SR100UU     | 110                  | 3              | 100      | +58/+36          | 130     | 0/-25           | 100     | -0.4      | 77      | 3       | 1.5     | 2.5               | 2       | 8,430             | 14,700            | 2,440     |

1N≅0.102kgf

# SR-B TYPE



## part number structure

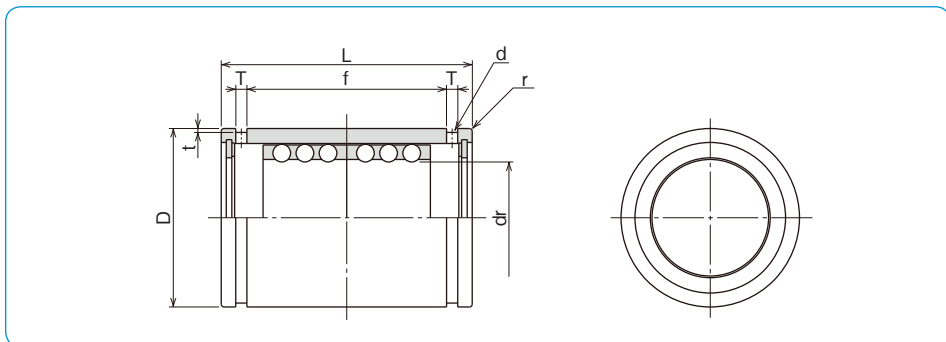
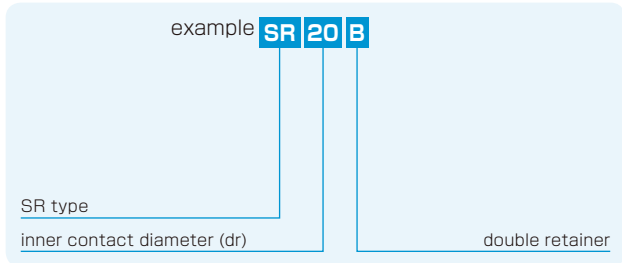

| part number | maximum stroke<br>mm | number of rows | dr<br>mm | major dimensions |         |                 |         |                 |         |         |         |         |         | basic load rating |                   |           |
|-------------|----------------------|----------------|----------|------------------|---------|-----------------|---------|-----------------|---------|---------|---------|---------|---------|-------------------|-------------------|-----------|
|             |                      |                |          | tolerance<br>μm  | D<br>mm | tolerance<br>μm | L<br>mm | tolerance<br>mm | f<br>mm | T<br>mm | t<br>mm | d<br>mm | r<br>mm | dynamic<br>C<br>N | static<br>Co<br>N | mass<br>g |
| SR 8B       | 8                    | 6              | 8        | +22              | 15      | 0/-11           | 24      | 0               | 17.1    | 1.5     | 0.5     | 1.2     | 0.5     | 549               | 490               | 16.8      |
| SR 10B      | 8                    | 6              | 10       | +13              | 19      | 0               | 30      | 0               | 22.7    | 1.5     | 0.5     | 1.2     | 0.5     | 1,030             | 931               | 31.2      |
| SR 12B      | 8                    | 6              | 12       | +27              | 23      | -13             | 32      | -0.2            | 24.5    | 1.5     | 0.5     | 1.2     | 0.5     | 1,720             | 1,630             | 46        |
| SR 16B      | 16                   | 6              | 16       | +16              | 28      | 0               | 37      | 0               | 29.1    | 1.5     | 0.7     | 1.3     | 0.5     | 1,910             | 1,980             | 75        |
| SR 20B      | 20                   | 6              | 20       | +33              | 32      | 0               | 45      | 0               | 35.8    | 2       | 0.7     | 1.5     | 0.5     | 2,060             | 2,320             | 106       |
| SR 25B      | 20                   | 6              | 25       | +20              | 37      | -16             | 45      | 0               | 35.8    | 2       | 0.7     | 1.6     | 1       | 2,170             | 2,670             | 125       |
| SR 30B      | 44                   | 6              | 30       | +33              | 45      | 0               | 65      | 0               | 53.5    | 2.5     | 1       | 2       | 1       | 4,800             | 6,270             | 220       |
| SR 35B      | 54                   | 6              | 35       | +41              | 52      | 0               | 70      | 0               | 58.5    | 2.5     | 1       | 2       | 1.5     | 5,050             | 7,060             | 346       |
| SR 40B      | 66                   | 6              | 40       | +25              | 60      | -19             | 80      | -0.3            | 68.3    | 2.5     | 1       | 2       | 1.5     | 6,710             | 9,560             | 540       |
| SR 50B      | 88                   | 6              | 50       | +25              | 72      | -19             | 100     | -0.3            | 86.4    | 3       | 1       | 2.5     | 1.5     | 8,970             | 13,800            | 862       |
| SR 60B      | 88                   | 6              | 60       | +49              | 85      | 0               | 100     | 0               | 86.4    | 3       | 1       | 2.5     | 2       | 9,700             | 16,500            | 1,290     |
| SR 80B      | 76                   | 6              | 80       | +30              | 110     | -22             | 100     | 0               | 86      | 3       | 1.5     | 2.5     | 2       | 12,700            | 24,300            | 2,110     |
| SR 100B     | 76                   | 6              | 100      | +58/+36          | 130     | 0/-25           | 100     | -0.4            | 86      | 3       | 1.5     | 2.5     | 2       | 13,700            | 29,400            | 2,520     |

1N≅0.102kgf

# SR-BUU TYPE



## part number structure

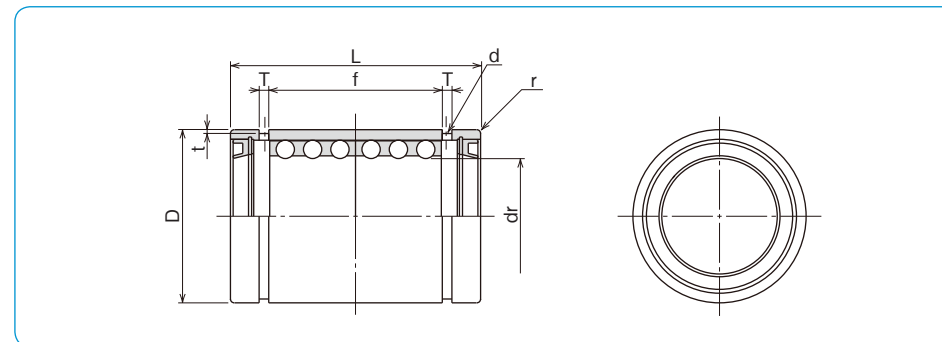
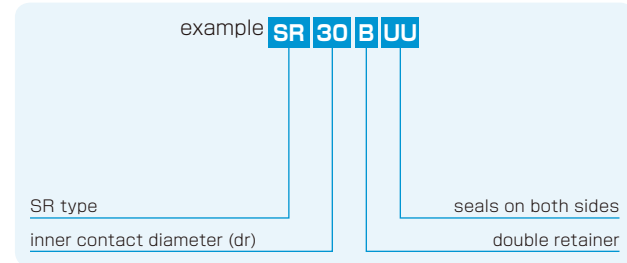

| part number | maximum stroke<br>mm | number of rows | dr<br>mm | major dimensions |         |                 |         |                 |         |         |         |         |         | basic load rating |                   |           |
|-------------|----------------------|----------------|----------|------------------|---------|-----------------|---------|-----------------|---------|---------|---------|---------|---------|-------------------|-------------------|-----------|
|             |                      |                |          | tolerance<br>μm  | D<br>mm | tolerance<br>μm | L<br>mm | tolerance<br>mm | f<br>mm | T<br>mm | t<br>mm | d<br>mm | r<br>mm | dynamic<br>C<br>N | static<br>Co<br>N | mass<br>g |
| SR 30BUU    | 30                   | 6              | 30       | +33/+20          | 45      | 0/-16           | 65      | 0               | 45.1    | 2.5     | 1       | 2       | 1       | 4,800             | 6,270             | 220       |
| SR 35BUU    | 38                   | 6              | 35       | +41              | 52      | 0               | 70      | 0               | 50.1    | 2.5     | 1       | 2       | 1.5     | 5,050             | 7,060             | 346       |
| SR 40BUU    | 49                   | 6              | 40       | +25              | 60      | -19             | 80      | -0.3            | 59.9    | 2.5     | 1       | 2       | 1.5     | 6,710             | 9,560             | 540       |
| SR 50BUU    | 66                   | 6              | 50       | +25              | 72      | -19             | 100     | -0.3            | 77.4    | 3       | 1       | 2.5     | 1.5     | 8,970             | 13,800            | 862       |
| SR 60BUU    | 67                   | 6              | 60       | +49              | 85      | 0               | 100     | 0               | 77.4    | 3       | 1       | 2.5     | 2       | 9,700             | 16,500            | 1,290     |
| SR 80BUU    | 54                   | 6              | 80       | +30              | 110     | -22             | 100     | 0               | 77      | 3       | 1.5     | 2.5     | 2       | 12,700            | 24,300            | 2,110     |
| SR 100BUU   | 54                   | 6              | 100      | +58/+36          | 130     | 0/-25           | 100     | -0.4            | 77      | 3       | 1.5     | 2.5     | 2       | 13,700            | 29,400            | 2,520     |

1N≅0.102kgf

# SLIDE ROTARY BUSH SRE SERIES

The NB Slide Rotary Bush SRE Series provides rotary and linear motion functions. Linear motion with unlimited stroke and rotary motion are merged into a single bush resulting in great space saving compared with a combination of any conventional bearings. There are three types; standard, flange, and unit type with sizes ranging from 6 to 40.

## STRUCTURE AND ADVANTAGES

NB Slide Rotary Bush features a special retainer fitted into cylindrical steel outer cylinder and is designed to guide steel balls for smooth circulation in its retainer. The retainer is also designed to rotate freely towards radial direction and offers smooth linear and rotary motions.

### ●Smooth Operation

The inner surface of the outer cylinder allows smooth operation of linear and rotary motions while maintaining a uniform load distribution.

### ●High Load Capacity

The use of comparatively large diameter steel balls enhances the load capacity.

### ●Smooth Rotation

The positioning of the steel balls in a cylindrical formation inside the retainer enables a smooth rotational motion regardless of the installation direction.

### ●Complete Interchangeability

NB Slide Rotary series is completely interchangeable with SM type Slide Bush, SMK type Flanged Slide Bush and SMA(W) type, AK(W) type and SMP type.

Figure E-3 Structure of Slide Rotary Bush SRE type

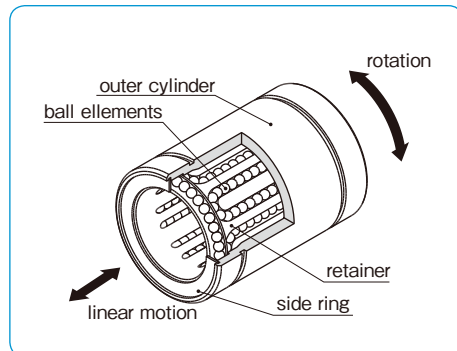

## RATED LIFE AND LOAD RATING

The rated life and load rating are defined as follows.

### ●Rated Life

When a group of slide rotary bearings of the same type are used under the same conditions, the rated life is defined as the total number of rotations made without causing flaking by 90% of the bearings.

### ●Basic Dynamic Load Rating

The basic dynamic load rating is defined as the load with a constant magnitude and direction at which a rated life of  $10^6$  rotations can be achieved.

### ●Basic Static Load Rating

The basic static load rating is defined as the load with a constant direction that would result in a certain contact stress at the mid-point of the rolling element and tracking surface that are experiencing the maximum stress.

Equation (1) gives the relation between the applied load and the rated life of the slide rotary bush.

$$L = \left( \frac{f_H \cdot f_T \cdot f_C}{f_W} \cdot \frac{C}{P} \right)^3 \dots \dots \dots (1)$$

L: rated life ( $10^6$  rotations)  $f_H$ : hardness coefficient  
 $f_T$ : temperature coefficient  $f_C$ : contact coefficient  
 $f_W$ : applied load coefficient C: basic dynamic load rating (N)  
 P: applied load (N)  
 ※Refer to page Eng-5 for the coefficients.

Since the slide rotary bush is used in applications with combined linear and rotary motions, the life time is obtained using Equations (2) and (3).

### ●When linear and rotary motions are combined

$$L_h = \frac{10^6 \cdot L}{60\sqrt{(dm \cdot n)^2 + (10 \cdot S \cdot n_1)^2} / dm} \dots \dots (2)$$

### ●When only linear motion is involved

$$L_h = \frac{10^6 \cdot L}{600 \cdot S \cdot n_1 / (\pi \cdot dm)} \dots \dots \dots (3)$$

L: life time (hr) S: stroke length (mm) n: revolutions per minute (rpm)  $n_1$ : number of cycles per minute (cpm)  
 dm: ball pitch diameter (mm)  $\approx 1.15dr$  (dr is the inner contact diameter of the SRE series)

## Calculation Example

The life of SRE20 type NB slide rotary bush is calculated based on the following conditions.

### ●Conditions

Motion: Linear and rotational combined Load: P=30N Stroke: S=200mm  
 Revolutions per minute: n=15rpm Number of cycles per minute:  $n_1=10$ cpm  
 Shaft surface hardness: greater than 58 HRC  
 Operating temperature: room temperature Other: single shaft with single bush

### ●Calculation

Basic dynamic load rating: C=647 N  
 Based on the above conditions, the life is calculated using the following coefficient values.  
 Hardness coefficient  $f_H=1$ , Temperature coefficient  $f_T=1$ , Contact coefficient  $f_C=1$   
 Applied load coefficient,  $f_W=1.5$

Rated life

$$L = \left( \frac{f_H \cdot f_T \cdot f_C}{f_W} \cdot \frac{C}{P} \right)^3$$

$$= \left( \frac{1 \times 1 \times 1}{1.5} \cdot \frac{647}{30} \right)^3 = 2,972 \text{ (} 10^6 \text{ rotations)}$$

Life (in hours)

$$L_h = \frac{10^6 \cdot L}{60\sqrt{(dm \cdot n)^2 + (10 \cdot S \cdot n_1)^2} / dm}$$

$$= \frac{10^6 \times 2,972}{60\sqrt{(1.15 \times 20 \times 15)^2 + (10 \times 200 \times 10)^2} / (1.15 \times 20)}$$

$$= 56,900 \text{ (h)}$$

APPLICATION EXAMPLES

Application Example 1 Vertical Shaft Robot Arm

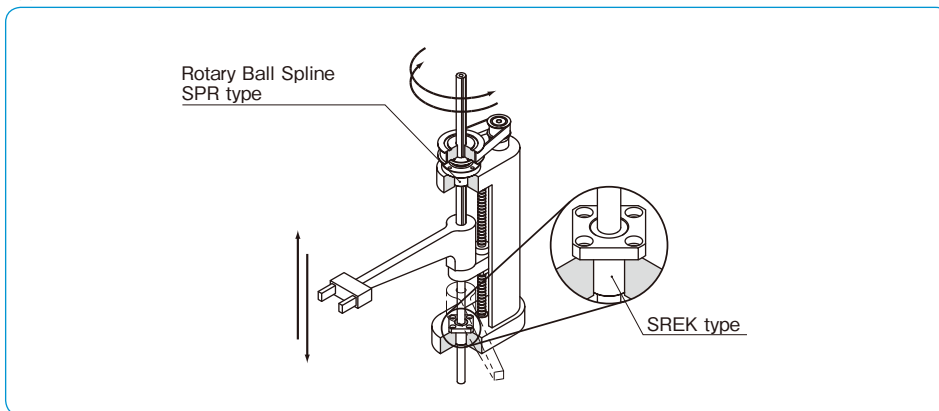

Application Example 2 Multiple Gearing Idler

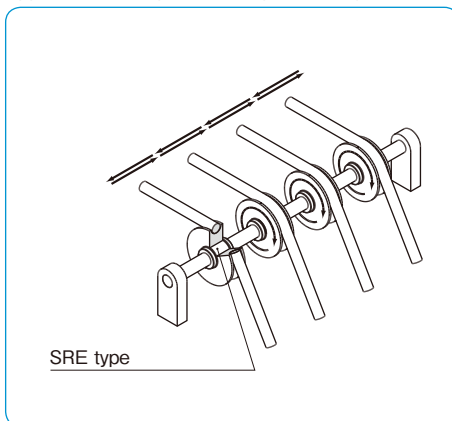

Application Example 4 Turntable

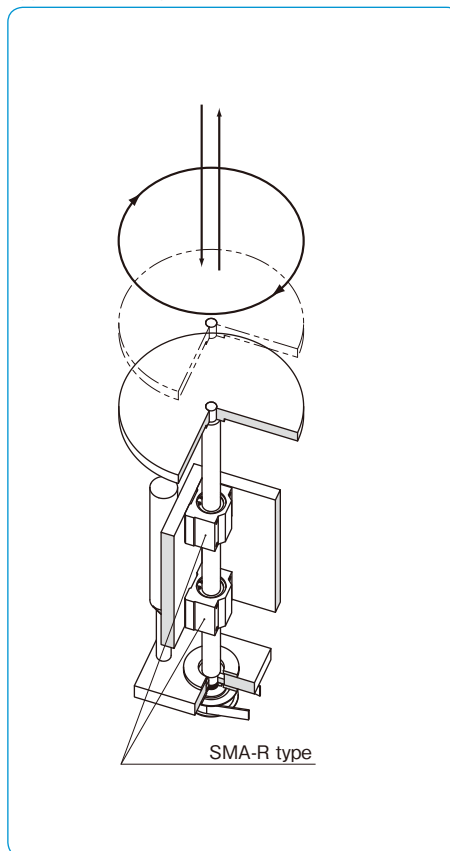

Application Example 3 Tool Changer

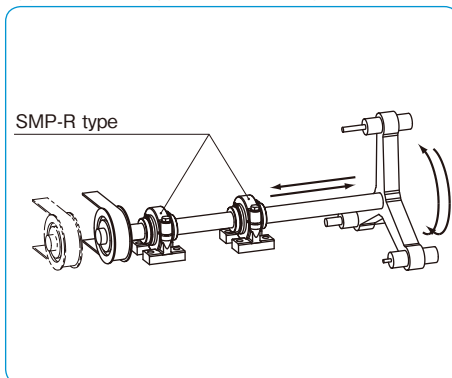

USE AND HANDLING PRECAUTIONS

● Shaft

Since the ball elements rotate on the shaft surface in the SRE type slide rotary bush, the accuracy and hardness of the shaft are important factors.

Outer Diameter: A tolerance of g6 is recommended for smooth operation.

Hardness: A hardness of greater than 58HRC is recommended for long life. If the hardness is less than 58 HRC, the life is calibrated using the hardness coefficient.

Surface Roughness: A roughness of less than 0.4Ra is recommended.

● Housing

An inner diameter tolerance of H7 is recommended for housing.

● Lubrication

Lubrication is needed (1) to prevent heat fusing by reducing friction between the rolling elements and the tracking surface, (2) to reduce wear of the structural elements, and (3) to prevent rusting.

Lubrication affects both the performance and life of the bush. A lubrication method and a lubrication agent appropriate to the operating conditions should be selected. For oil lubrication, turbine oil (ISO standard VG32-68) is recommended. For grease lubrication, lithium soap based grease No. 2 is recommended. The replenishment interval depends on the operating conditions.

● Dust Prevention

Dust and other contaminants affect the bush's lifetime and accuracy. Appropriate prevention methods are thus important.

● Operating Temperature Range

The operating temperature is ranging from -20°C to 110°C. In case of operation at a temperature outside this range, please contact NB.

● Retainer Material

The standard material of SRE Retainer is copper alloy. When requiring other material, please contact NB.

FELT SEAL

A felt seal FLM strengthens lubrication characteristics and extends relubrication period of the slide rotary bush.

Figure E-4 Felt Seal

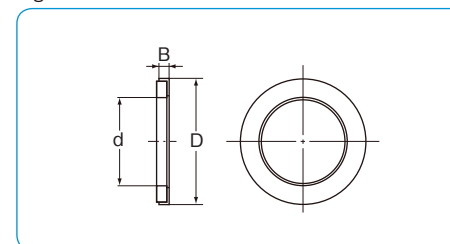

Installation

The felt seal does not work as a retaining ring. Figure E-5 shows how to install the felt seal.

Table E-3 Felt Seal Dimensions

| part number | major dimensions (mm) |    |   | applicable slide rotary bush |
|-------------|-----------------------|----|---|------------------------------|
|             | d                     | D  | B |                              |
| FLM 6       | 6                     | 12 | 2 | SRE 6                        |
| FLM 8       | 8                     | 15 | 2 | SRE 8                        |
| FLM 10      | 10                    | 19 | 3 | SRE 10                       |
| FLM 12      | 12                    | 21 | 3 | SRE 12                       |
| FLM 13      | 13                    | 23 | 3 | SRE 13                       |
| FLM 16      | 16                    | 28 | 4 | SRE 16                       |
| FLM 20      | 20                    | 32 | 4 | SRE 20                       |
| FLM 25      | 25                    | 40 | 5 | SRE 25                       |
| FLM 30      | 30                    | 45 | 5 | SRE 30                       |
| FLM 40      | 40                    | 60 | 5 | SRE 40                       |

Figure E-5 Example of Installation

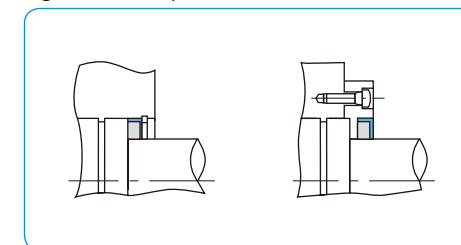

# SRE TYPE



## part number structure

example **SRE 25**

SRE type

inner contact diameter (dr)

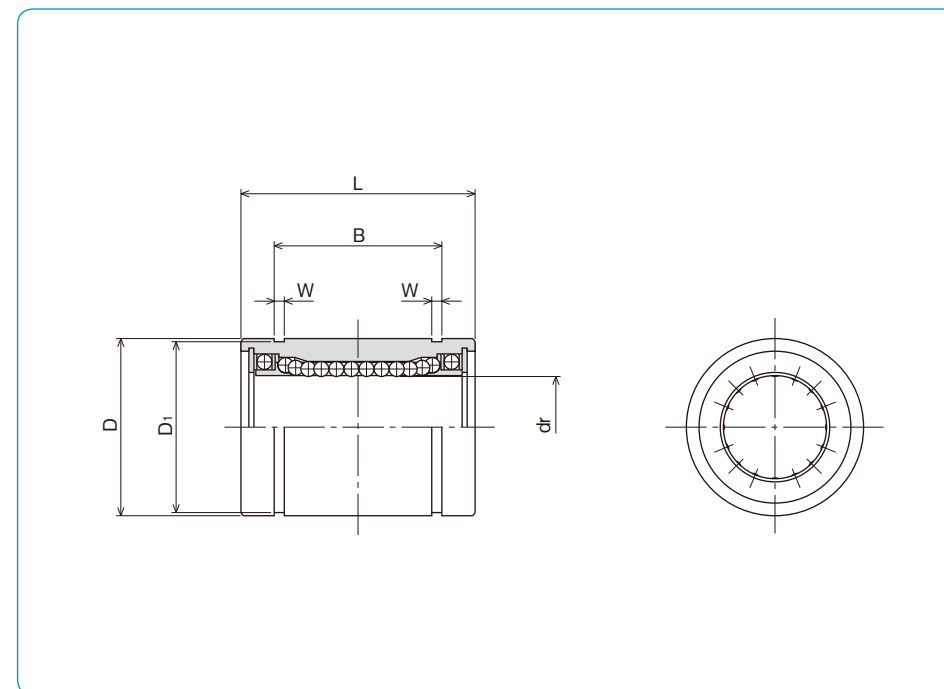

| part number  | dr |                         | D  |                         | major dimensions |      |              | B    | tolerance mm |
|--------------|----|-------------------------|----|-------------------------|------------------|------|--------------|------|--------------|
|              | mm | tolerance $\mu\text{m}$ | mm | tolerance $\mu\text{m}$ | L                | L    | tolerance mm |      |              |
| <b>SRE 6</b> | 6  |                         | 12 | 0                       | 19               | 0    | 13.5         | 0    |              |
| <b>SRE 8</b> | 8  | +4                      | 15 | -11                     | 24               |      | 17.5         |      |              |
| <b>SRE10</b> | 10 | -5                      | 19 |                         | 29               |      | 22           |      |              |
| <b>SRE12</b> | 12 |                         | 21 | 0                       | 30               |      | 23           |      |              |
| <b>SRE13</b> | 13 | +3                      | 23 | -13                     | 32               | -0.2 | 23           | -0.2 |              |
| <b>SRE16</b> | 16 | -6                      | 28 |                         | 37               |      | 26.5         |      |              |
| <b>SRE20</b> | 20 |                         | 32 |                         | 42               | 0    | 30.5         | 0    |              |
| <b>SRE25</b> | 25 | +3                      | 40 | 0                       | 59               |      | 41           |      |              |
| <b>SRE30</b> | 30 | -7                      | 45 | -16                     | 64               |      | 44.5         |      |              |
| <b>SRE40</b> | 40 | +3/-8                   | 60 | 0/-19                   | 80               |      | -0.3         |      | 60.5         |

※If the inner contact diameter exceeds 40 mm, please contact NB.

| W    | D1   | basic load rating |             | allowable revolutions per minute rpm | mass g | part number  |
|------|------|-------------------|-------------|--------------------------------------|--------|--------------|
|      |      | dynamic C N       | static Co N |                                      |        |              |
| 1.1  | 11.5 | 78                | 176         | 300                                  | 10     | <b>SRE 6</b> |
| 1.1  | 14.3 | 137               | 314         | 300                                  | 20     | <b>SRE 8</b> |
| 1.3  | 18   | 157               | 372         | 300                                  | 39     | <b>SRE10</b> |
| 1.3  | 20   | 274               | 588         | 300                                  | 42     | <b>SRE12</b> |
| 1.3  | 22   | 323               | 686         | 300                                  | 56     | <b>SRE13</b> |
| 1.6  | 27   | 451               | 882         | 250                                  | 97     | <b>SRE16</b> |
| 1.6  | 30.5 | 647               | 1,180       | 250                                  | 133    | <b>SRE20</b> |
| 1.85 | 38   | 882               | 1,860       | 250                                  | 293    | <b>SRE25</b> |
| 1.85 | 43   | 1,180             | 2,650       | 200                                  | 371    | <b>SRE30</b> |
| 2.1  | 57   | 1,960             | 4,020       | 200                                  | 778    | <b>SRE40</b> |

1N=0.102kgf

# SREK TYPE

– Square Flange type –

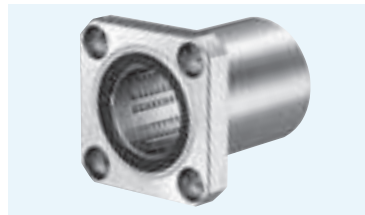

## part number structure

example **SREK 25**

SREK type

inner contact diameter (dr)

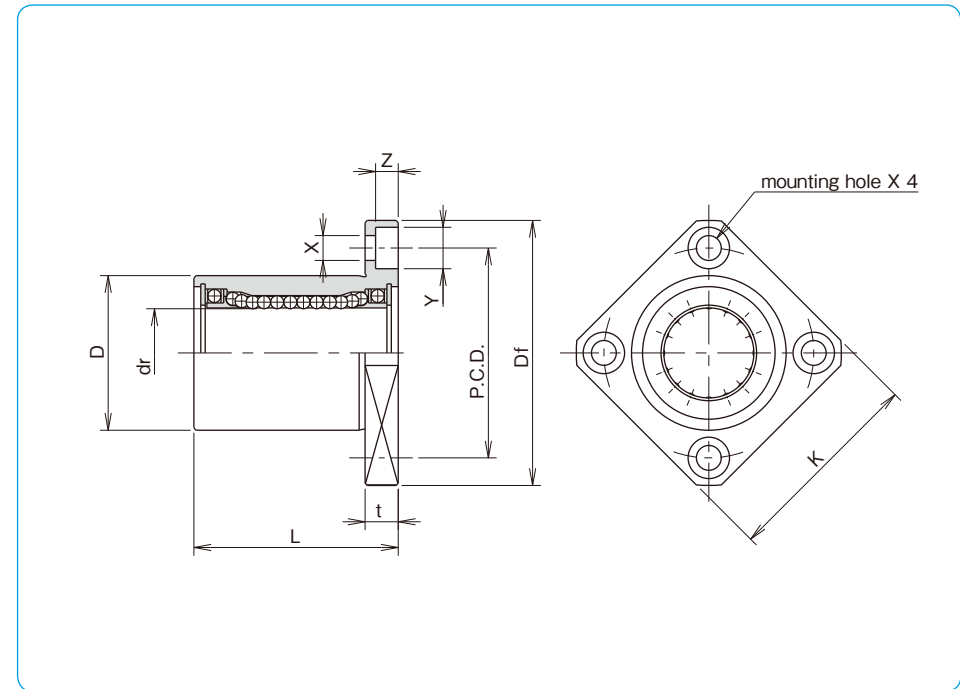

| part number   | dr |                 | D  |                 | major dimensions |          |         |                   |
|---------------|----|-----------------|----|-----------------|------------------|----------|---------|-------------------|
|               | mm | tolerance<br>μm | mm | tolerance<br>μm | L<br>±0.3<br>mm  | Df<br>mm | K<br>mm | flange<br>t<br>mm |
| <b>SREK 6</b> | 6  |                 | 12 | 0               | 19               | 28       | 22      | 5                 |
| <b>SREK 8</b> | 8  | +4              | 15 | -13             | 24               | 32       | 25      | 5                 |
| <b>SREK10</b> | 10 | -5              | 19 |                 | 29               | 40       | 30      | 6                 |
| <b>SREK12</b> | 12 |                 | 21 | 0               | 30               | 42       | 32      | 6                 |
| <b>SREK13</b> | 13 | +3              | 23 | -16             | 32               | 43       | 34      | 6                 |
| <b>SREK16</b> | 16 | -6              | 28 |                 | 37               | 48       | 37      | 6                 |
| <b>SREK20</b> | 20 |                 | 32 | 0               | 42               | 54       | 42      | 8                 |
| <b>SREK25</b> | 25 | +3              | 40 | -19             | 59               | 62       | 50      | 8                 |
| <b>SREK30</b> | 30 | -7              | 45 |                 | 64               | 74       | 58      | 10                |

| P.C.D.<br>mm | X×Y×Z<br>mm | perpendicularity<br>μm | basic load rating |                   | allowable<br>revolutions<br>per minute<br>rpm | mass<br>g | part number   |
|--------------|-------------|------------------------|-------------------|-------------------|---|-----------|---------------|
|              |             |                        | dynamic<br>C<br>N | static<br>Co<br>N |   |           |               |
| 20           | 3.5×6×3.1   | 12                     | 78                | 176               | 300   | 21        | <b>SREK 6</b> |
| 24           | 3.5×6×3.1   |                        | 137               | 314               | 300   | 33        | <b>SREK 8</b> |
| 29           | 4.5×7.5×4.1 |                        | 157               | 372               | 300   | 61        | <b>SREK10</b> |
| 32           | 4.5×7.5×4.1 |                        | 274               | 588               | 300   | 67        | <b>SREK12</b> |
| 33           | 4.5×7.5×4.1 |                        | 323               | 686               | 300   | 83        | <b>SREK13</b> |
| 38           | 4.5×7.5×4.1 |                        | 451               | 882               | 250   | 126       | <b>SREK16</b> |
| 43           | 5.5×9×5.1   | 15                     | 647               | 1,180             | 250   | 178       | <b>SREK20</b> |
| 51           | 5.5×9×5.1   |                        | 882               | 1,860             | 250   | 355       | <b>SREK25</b> |
| 60           | 6.6×11×6.1  |                        | 1,180             | 2,650             | 200   | 483       | <b>SREK30</b> |

1N≒0.102kgf

# SMA-R TYPE

—Block type—



## part number structure

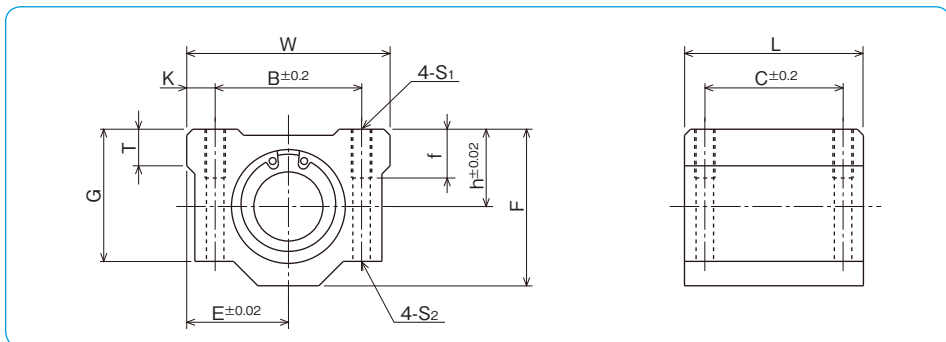
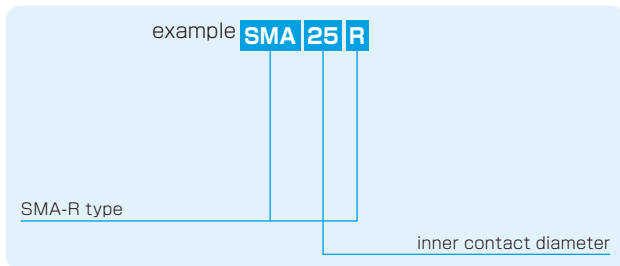

| part number | inner contact diameter |                 | major dimensions |    |     |    |                     |      |    |      |    |      |                |        |                |       | basic load rating |     | allowable revolutions per minute | mass |
|-------------|------------------------|-----------------|------------------|----|-----|----|---------------------|------|----|------|----|------|----------------|--------|----------------|-------|-------------------|-----|----------------------------------|------|
|             | mm                     | tolerance<br>μm | outer dimensions |    |     |    | mounting dimensions |      |    |      |    |      | dynamic        | static | rpm            | g     |                   |     |                                  |      |
|             |                        |                 | h                | E  | W   | L  | F                   | G    | T  | B    | C  | K    | S <sub>1</sub> | f      | S <sub>2</sub> | C     | Co                |     |                                  |      |
| SMA 6R      | 6                      |                 | 9                | 15 | 30  | 25 | 18                  | 15   | 6  | 20   | 15 | 5    | M4             | 8      | 3.4            | 78    | 176               | 300 | 33                               |      |
| SMA 8R      | 8                      | +4              | 11               | 17 | 34  | 30 | 22                  | 18   | 6  | 24   | 18 | 5    | M4             | 8      | 3.4            | 137   | 314               | 300 | 55                               |      |
| SMA 10R     | 10                     | -5              | 13               | 20 | 40  | 35 | 26                  | 21   | 8  | 28   | 21 | 6    | M5             | 12     | 4.3            | 157   | 372               | 300 | 93                               |      |
| SMA 12R     | 12                     |                 | 15               | 21 | 42  | 36 | 28                  | 24   | 8  | 30.5 | 26 | 5.75 | M5             | 12     | 4.3            | 274   | 588               | 300 | 104                              |      |
| SMA 13R     | 13                     | +3              | 15               | 22 | 44  | 39 | 30                  | 24.5 | 8  | 33   | 26 | 5.5  | M5             | 12     | 4.3            | 323   | 686               | 300 | 128                              |      |
| SMA 16R     | 16                     | -6              | 19               | 25 | 50  | 44 | 38.5                | 32.5 | 9  | 36   | 34 | 7    | M5             | 12     | 4.3            | 451   | 882               | 250 | 216                              |      |
| SMA 20R     | 20                     |                 | 21               | 27 | 54  | 50 | 41                  | 35   | 11 | 40   | 40 | 7    | M6             | 12     | 5.2            | 647   | 1,180             | 250 | 286                              |      |
| SMA 25R     | 25                     | +3              | 26               | 38 | 76  | 67 | 51.5                | 42   | 12 | 54   | 50 | 11   | M8             | 18     | 7              | 882   | 1,860             | 250 | 645                              |      |
| SMA 30R     | 30                     | -7              | 30               | 39 | 78  | 72 | 59.5                | 49   | 15 | 58   | 58 | 10   | M8             | 18     | 7              | 1,180 | 2,650             | 200 | 824                              |      |
| SMA 40R     | 40                     | +3/-8           | 40               | 51 | 102 | 90 | 78                  | 62   | 20 | 80   | 60 | 11   | M10            | 25     | 8.7            | 1,960 | 4,020             | 200 | 1,719                            |      |

1N=0.102kgf

# SMA-RW TYPE

—Double-Wide Block type—



## part number structure

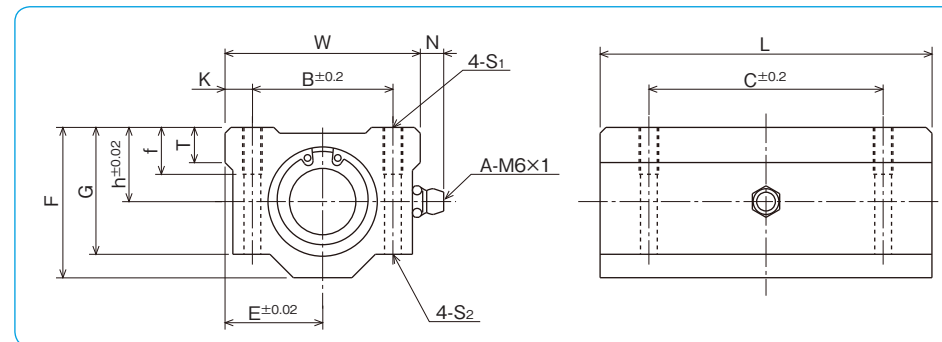
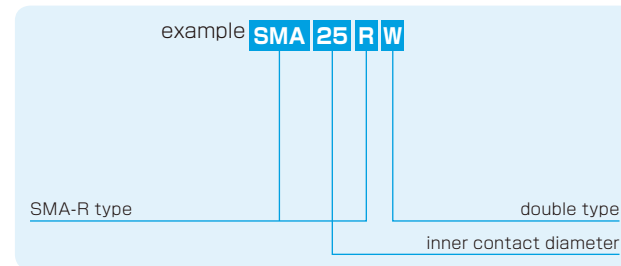

| part number | inner contact diameter |                 | major dimensions |    |     |     |                     |      |    |     |      |     |         |                |     |                | basic load rating |       | allowable revolutions per minute | mass  |
|-------------|------------------------|-----------------|------------------|----|-----|-----|---------------------|------|----|-----|------|-----|---------|----------------|-----|----------------|-------------------|-------|----------------------------------|-------|
|             | mm                     | tolerance<br>μm | outer dimensions |    |     |     | mounting dimensions |      |    |     |      |     | dynamic | static         | rpm | g              |                   |       |                                  |       |
|             |                        |                 | h                | E  | W   | L   | F                   | G    | T  | N   | B    | C   | K       | S <sub>1</sub> | f   | S <sub>2</sub> | C                 | Co    |                                  |       |
| SMA 6RW     | 6                      |                 | 9                | 15 | 30  | 48  | 18                  | 15   | 6  | 7   | 20   | 36  | 5       | M4             | 8   | 3.4            | 126               | 352   | 300                              | 68    |
| SMA 8RW     | 8                      | +4              | 11               | 17 | 34  | 58  | 22                  | 18   | 6  | 7   | 24   | 42  | 5       | M4             | 8   | 3.4            | 222               | 628   | 300                              | 113   |
| SMA 10RW    | 10                     | -5              | 13               | 20 | 40  | 68  | 26                  | 21   | 8  | 7   | 28   | 46  | 6       | M5             | 12  | 4.3            | 254               | 744   | 300                              | 188   |
| SMA 12RW    | 12                     |                 | 15               | 21 | 42  | 70  | 28                  | 24   | 8  | 6.5 | 30.5 | 50  | 5.75    | M5             | 12  | 4.3            | 444               | 1,180 | 300                              | 210   |
| SMA 13RW    | 13                     | +3              | 15               | 22 | 44  | 75  | 30                  | 24.5 | 8  | 6.5 | 33   | 50  | 5.5     | M5             | 12  | 4.3            | 523               | 1,370 | 300                              | 254   |
| SMA 16RW    | 16                     | -6              | 19               | 25 | 50  | 85  | 38.5                | 32.5 | 9  | 6   | 36   | 60  | 7       | M5             | 12  | 4.3            | 731               | 1,760 | 250                              | 431   |
| SMA 20RW    | 20                     |                 | 21               | 27 | 54  | 96  | 41                  | 35   | 11 | 7   | 40   | 70  | 7       | M6             | 12  | 5.2            | 1,050             | 2,360 | 250                              | 568   |
| SMA 25RW    | 25                     | +3              | 26               | 38 | 76  | 130 | 51.5                | 42   | 12 | 4   | 54   | 100 | 11      | M8             | 18  | 7              | 1,430             | 3,720 | 250                              | 1,282 |
| SMA 30RW    | 30                     | -7              | 30               | 39 | 78  | 140 | 59.5                | 49   | 15 | 5   | 58   | 110 | 10      | M8             | 18  | 7              | 1,910             | 5,300 | 200                              | 1,638 |
| SMA 40RW    | 40                     | +3/-8           | 40               | 51 | 102 | 175 | 78                  | 62   | 20 | 5   | 80   | 140 | 11      | M10            | 25  | 8.7            | 3,180             | 8,040 | 200                              | 3,419 |

1N=0.102kgf

# AK-R TYPE

-Compact Block type-



## part number structure

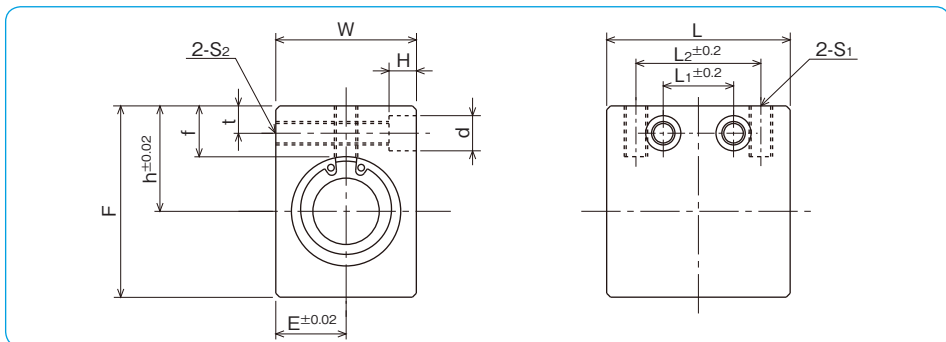
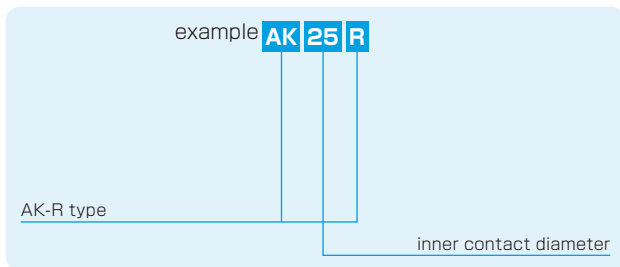

| part number | inner contact diameter |                 | major dimensions |    |    |                     |    |                |                |      |                |   |                |        |    | basic load rating |       | allowable revolutions per minute | mass |     |   |
|-------------|------------------------|-----------------|------------------|----|----|---------------------|----|----------------|----------------|------|----------------|---|----------------|--------|----|-------------------|-------|----------------------------------|------|-----|---|
|             | mm                     | tolerance<br>μm | outer dimensions |    |    | mounting dimensions |    |                |                |      |                |   | dynamic        | static |    |                   |       |                                  |      |     |   |
|             |                        |                 | h                | E  | W  | L                   | F  | L <sub>2</sub> | S <sub>1</sub> | f    | L <sub>1</sub> | t | S <sub>2</sub> | d      | H  | C                 | Co    | N                                | N    | rpm | g |
| AK 6R       | 6                      |                 | 14               | 8  | 16 | 27                  | 22 | 18             | M4             | 8    | 9              | 5 | M4             | 6      | 5  | 78                | 176   | 300                              | 27   |     |   |
| AK 8R       | 8                      | +4              | 16               | 10 | 20 | 32                  | 26 | 20             | M5             | 8.5  | 10             | 5 | M4             | 6      | 5  | 137               | 314   | 300                              | 48   |     |   |
| AK10R       | 10                     | -5              | 19               | 13 | 26 | 39                  | 32 | 27             | M6             | 9.5  | 15             | 6 | M5             | 8      | 6  | 157               | 372   | 300                              | 94   |     |   |
| AK12R       | 12                     |                 | 20               | 14 | 28 | 40                  | 34 | 27             | M6             | 9.5  | 15             | 6 | M5             | 8      | 6  | 274               | 588   | 300                              | 105  |     |   |
| AK13R       | 13                     | +3              | 25               | 15 | 30 | 42                  | 43 | 28             | M6             | 13.5 | 16             | 7 | M6             | 9      | 7  | 323               | 686   | 300                              | 151  |     |   |
| AK16R       | 16                     | -6              | 27               | 18 | 36 | 47                  | 49 | 32             | M6             | 13   | 18             | 7 | M6             | 9      | 7  | 451               | 882   | 250                              | 238  |     |   |
| AK20R       | 20                     |                 | 31               | 21 | 42 | 52                  | 54 | 36             | M8             | 15   | 18             | 8 | M8             | 11     | 8  | 647               | 1,180 | 250                              | 328  |     |   |
| AK25R       | 25                     | +3              | 37               | 26 | 52 | 69                  | 65 | 42             | M10            | 17   | 22             | 9 | M10            | 14     | 10 | 882               | 1,860 | 250                              | 669  |     |   |
| AK30R       | 30                     | -7              | 40               | 29 | 58 | 74                  | 71 | 44             | M10            | 17.5 | 22             | 9 | M10            | 14     | 10 | 1,180             | 2,650 | 200                              | 856  |     |   |

1N≒0.102kgf

# AK-RW TYPE

-Double-Wide Compact Block type-



## part number structure

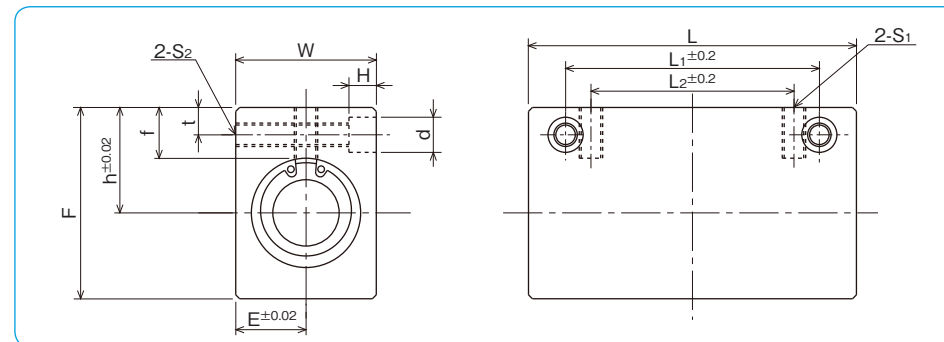
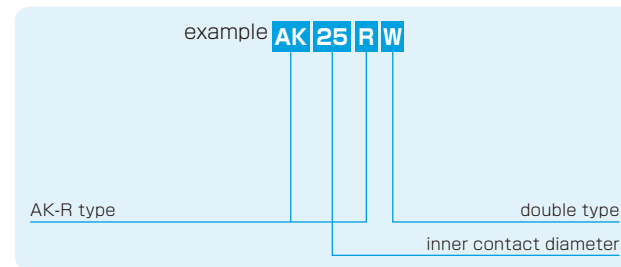

| part number | inner contact diameter |                 | major dimensions |    |    |                     |    |                |                |      |                |   |                |        |    | basic load rating |       | allowable revolutions per minute | mass  |     |   |
|-------------|------------------------|-----------------|------------------|----|----|---------------------|----|----------------|----------------|------|----------------|---|----------------|--------|----|-------------------|-------|----------------------------------|-------|-----|---|
|             | mm                     | tolerance<br>μm | outer dimensions |    |    | mounting dimensions |    |                |                |      |                |   | dynamic        | static |    |                   |       |                                  |       |     |   |
|             |                        |                 | h                | E  | W  | L                   | F  | L <sub>2</sub> | S <sub>1</sub> | f    | L <sub>1</sub> | t | S <sub>2</sub> | d      | H  | C                 | Co    | N                                | N     | rpm | g |
| AK 6RW      | 6                      |                 | 14               | 8  | 16 | 46                  | 22 | 20             | M4             | 8    | 30             | 5 | M4             | 6      | 5  | 126               | 352   | 300                              | 48    |     |   |
| AK 8RW      | 8                      | +4              | 16               | 10 | 20 | 56                  | 26 | 30             | M5             | 8.5  | 42             | 5 | M4             | 6      | 5  | 222               | 628   | 300                              | 89    |     |   |
| AK10RW      | 10                     | -5              | 19               | 13 | 26 | 68                  | 32 | 36             | M6             | 9.5  | 50             | 6 | M5             | 8      | 6  | 254               | 744   | 300                              | 175   |     |   |
| AK12RW      | 12                     |                 | 20               | 14 | 28 | 70                  | 34 | 36             | M6             | 9.5  | 50             | 6 | M5             | 8      | 6  | 444               | 1,180 | 300                              | 196   |     |   |
| AK13RW      | 13                     | +3              | 25               | 15 | 30 | 74                  | 43 | 42             | M6             | 13.5 | 55             | 7 | M6             | 9      | 7  | 523               | 1,370 | 300                              | 281   |     |   |
| AK16RW      | 16                     | -6              | 27               | 18 | 36 | 84                  | 49 | 52             | M6             | 13   | 65             | 7 | M6             | 9      | 7  | 731               | 1,760 | 250                              | 450   |     |   |
| AK20RW      | 20                     |                 | 31               | 21 | 42 | 94                  | 54 | 58             | M8             | 15   | 70             | 8 | M8             | 11     | 8  | 1,050             | 2,360 | 250                              | 626   |     |   |
| AK25RW      | 25                     | +3              | 37               | 26 | 52 | 128                 | 65 | 80             | M10            | 17   | 100            | 9 | M10            | 14     | 10 | 1,430             | 3,720 | 250                              | 1,299 |     |   |
| AK30RW      | 30                     | -7              | 40               | 29 | 58 | 138                 | 71 | 90             | M10            | 17.5 | 110            | 9 | M10            | 14     | 10 | 1,910             | 5,300 | 200                              | 1,662 |     |   |

1N≒0.102kgf

# SMP-R TYPE

—Pillow Block type—



## part number structure

example **SMP 25 R**

SMP-R type

inner contact diameter

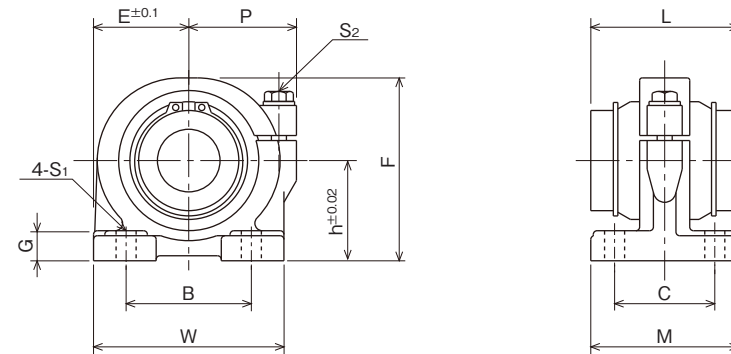

| part number   | inner contact diameter |                 | major dimensions |         |         |         |         |         |         |
|---------------|------------------------|-----------------|------------------|---------|---------|---------|---------|---------|---------|
|               | mm                     | tolerance<br>μm | outer dimensions |         |         |         |         |         |         |
|               |                        |                 | h<br>mm          | E<br>mm | W<br>mm | L<br>mm | F<br>mm | G<br>mm | M<br>mm |
| <b>SMP13R</b> | 13                     | +3              | 25               | 25      | 50      | 32      | 46      | 8       | 36      |
| <b>SMP16R</b> | 16                     | -6              | 29               | 27.5    | 55      | 37      | 53      | 10      | 40      |
| <b>SMP20R</b> | 20                     | +3<br>-7        | 34               | 32.5    | 65      | 42      | 62      | 12      | 48      |
| <b>SMP25R</b> | 25                     |                 | 40               | 38      | 76      | 59      | 73      | 12      | 59      |
| <b>SMP30R</b> | 30                     | +3/-8           | 45               | 42.5    | 85      | 64      | 84      | 15      | 69      |
| <b>SMP40R</b> | 40                     |                 | 60               | 62      | 124     | 80      | 112     | 18      | 86      |

| P<br>mm | mounting dimensions |         |          | adjustment<br>screw size<br>S2 | basic load rating |                   | allowable<br>revolutions<br>per minute<br>rpm | mass<br>g | part number   |
|---------|---------------------|---------|----------|--------------------------------|-------------------|-------------------|---|-----------|---------------|
|         | B<br>mm             | C<br>mm | S1<br>mm |                                | dynamic<br>C<br>N | static<br>Co<br>N |   |           |               |
| 30      | 30                  | 26      | 7 (M5)   | M5                             | 323               | 686               | 300   | 266       | <b>SMP13R</b> |
| 32      | 35                  | 29      | 7 (M5)   | M5                             | 451               | 882               | 250   | 369       | <b>SMP16R</b> |
| 37      | 40                  | 35      | 8 (M6)   | M6                             | 647               | 1,180             | 250   | 690       | <b>SMP20R</b> |
| 43      | 50                  | 40      | 8 (M6)   | M6                             | 882               | 1,860             | 250   | 970       | <b>SMP25R</b> |
| 49      | 58                  | 46      | 10 (M8)  | M8                             | 1,180             | 2,650             | 200   | 1,420     | <b>SMP30R</b> |
| 68      | 76                  | 64      | 12 (M10) | M10                            | 1,960             | 4,020             | 200   | 3,585     | <b>SMP40R</b> |

1N≐0.102kgf

# SLIDE ROTARY BUSH RK TYPE

NB's RK type slide rotary bush is a highly accurate and high load capacity bearing providing smooth continuous linear and rotational motions. Its structure imposes no constraints on linear and rotational motions. It is much more compact than a standard slide bush with separate rotational bearing.

## STRUCTURE AND ADVANTAGES

The RK type slide rotary bush uses a retainer similar to that used in the SR type stroke bush. This retainer gives a smooth motion in a high rotational application. SM type slide bush is incorporated, providing the stable and smooth linear motion. Relatively large ball elements are used for high load capacity.

1. A smooth unlimited linear and rotational motion is obtained.
2. There is no need to machine separate housing.
3. High accuracy is ensured for extended period of usage.
4. Its high compatibility eliminates replacement problems.
5. High rigidity enables it to withstand an unbalanced load and large load.

※For best performance, please select tolerance of h5 for the shaft.

### Calculation of Life:

$$L = \left( \frac{f_H \cdot f_T \cdot f_C \cdot C}{f_W \cdot P} \right)^3 \times 50$$

L: rated life (km) f<sub>H</sub>: hardness coefficient  
 f<sub>T</sub>: temperature coefficient f<sub>C</sub>: contact coefficient  
 f<sub>W</sub>: applied load coefficient  
 C: basic dynamic load rating (N) P: applied load (N)  
 ※Refer to page Eng-5 for the coefficients.

Figure E-6 Structure of RK Slide Rotary Bush

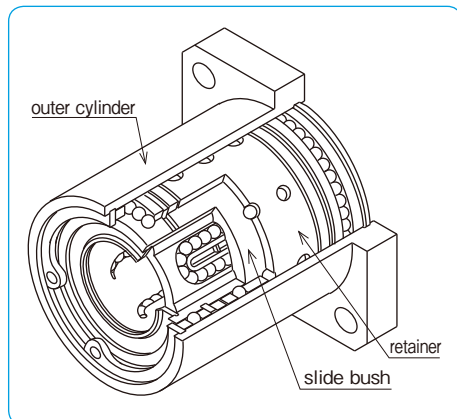

## RK TYPE



### part number structure

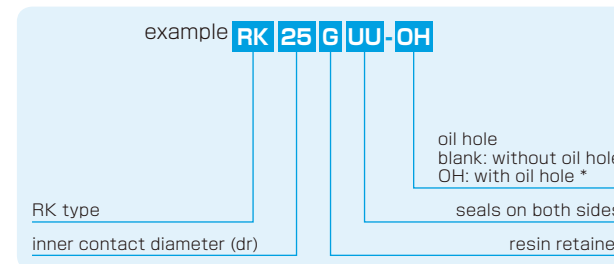

\*Oil hole is for rotary-portion lubrication.

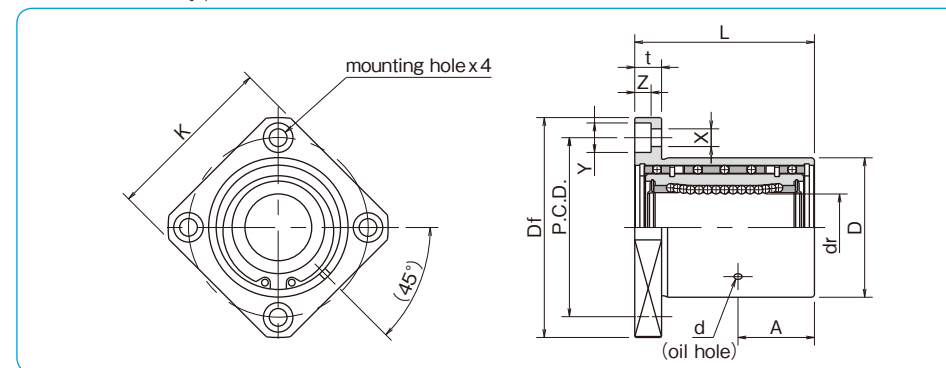

| part number    | dr |           | D  |           | L  |           | A    |    | d  |    | flange |    |            | basic load rating |       | allowable revolutions per minute | mass |
|----------------|----|-----------|----|-----------|----|-----------|------|----|----|----|--------|----|------------|-------------------|-------|----------------------------------|------|
|                | mm | tolerance | mm | tolerance | mm | tolerance | mm   | mm | mm | mm | Df     | K  | t          | P.C.D.            | X×Y×Z |                                  |      |
| <b>RK12GUU</b> | 12 | 0         | 32 | 0         | 36 |           | 15   | 2  | 54 | 42 | 8      | 43 | 5.5×9×5.1  | 510               | 784   | 500                              | 180  |
| <b>RK16GUU</b> | 16 | -9        | 40 | -25       | 45 |           | 19.5 | 2  | 62 | 50 | 8      | 51 | 5.5×9×5.1  | 774               | 1,180 | 500                              | 280  |
| <b>RK20GUU</b> | 20 | 0         | 45 | 0         | 50 | ±0.3      | 21.5 | 3  | 74 | 58 | 10     | 60 | 6.6×11×6.1 | 882               | 1,370 | 400                              | 420  |
| <b>RK25GUU</b> | 25 | 0         | 52 | 0         | 67 |           | 28.5 | 3  | 82 | 64 | 10     | 67 | 6.6×11×6.1 | 980               | 1,570 | 400                              | 680  |
| <b>RK30GUU</b> | 30 | -10       | 60 | -30       | 74 |           | 31   | 3  | 96 | 75 | 13     | 78 | 9×14×8.1   | 1,570             | 2,740 | 400                              | 990  |

1N≒0.102kgf

# SLIDE ROTARY BUSH FR/FRA TYPE

NB Slide Rotary Bush FR type provides combined functions of linear and rotary motion without stroke limitation. Unlike the traditional slide bush, ball elements are arranged around the shaft within the inner space of a bush maintaining compact dimensions while providing high load capacity and high rigidity.

## STRUCTURE AND ADVANTAGES

FR type is supplied as a set of a bush and shaft. Constructed with combination of a load carrying outer cylinder and a return cap, it is designed for smooth compound motions. For ease of mounting, the FRA type is also available, which has the FR bush preinstalled within a factory made housing.

### High Load Capacity, High Rigidity

High load capacity, high rigidity, and long life are achieved by ball elements placed all around the inner space between an outer cylinder and a linear shaft.

### Smooth Motion

Although it is an all-ball bearing construction, load carrying balls are designed to align along the linear direction to provide smooth motion in both linear and rotational directions.

### High Accuracy

Each set of a bush and shaft is matched and controlled to ensure smooth and highly accurate motion.

Figure E-7 Structure of FR type

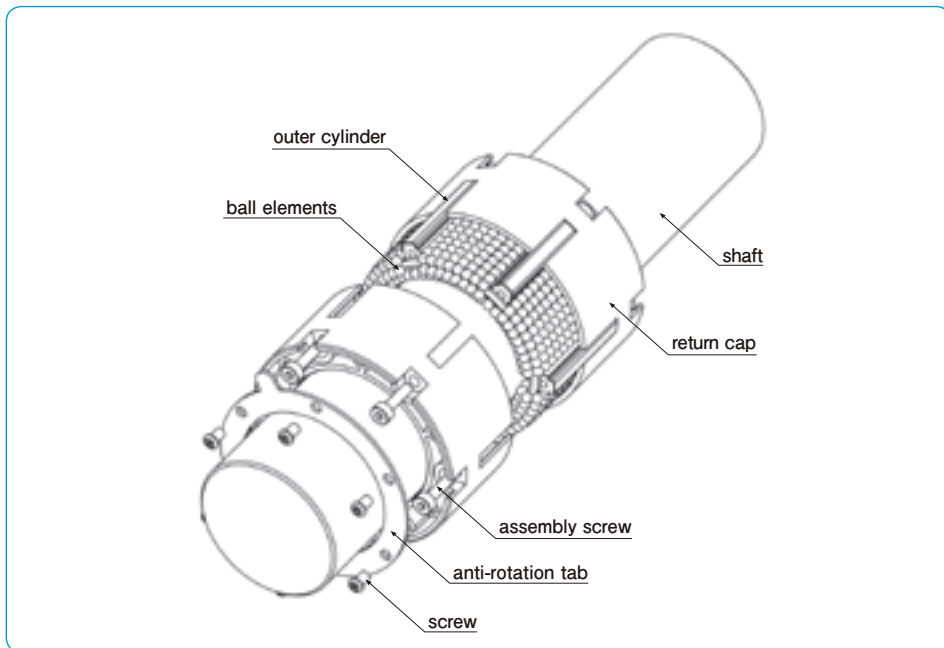

## RATED LIFE AND LOAD RATING

The rated life and load rating are defined as follows.

### Rated Life

When a group of slide rotary bushing of the same type are used under the same conditions, the rated life is the number of rotations achieved by 90% of the group without causing flaking.

### Basic Dynamic Load Rating

The basic dynamic load rating is the dynamic load with a constant direction and magnitude at which a rated life of 10<sup>6</sup> rotations can be achieved.

### Basic Static Load Rating

The basic static load rating is the static load with a constant direction that would result in a certain contact stress at the mid-point of the ball elements and tracking surface that are experiencing the maximum stress.

Equation (1) gives the relation between the applied load and the rated life of Slide Rotary Bush.

$$L = \left( \frac{f_c}{f_w} \cdot \frac{C}{P} \right)^3 \dots \dots \dots (1)$$

L: rated life (10<sup>6</sup> rotations) f<sub>c</sub>: contact coefficient (Table E-4) f<sub>w</sub>: applied load coefficient (Table E-5) C: basic dynamic load rating (N) P: applied load (N)

Table E-4 Contact Coefficient

| number of linear bearings in close contact on a shaft | contact coefficient f <sub>c</sub> |
|---|------------------------------------|
| 1   | 1.00                               |
| 2   | 0.81                               |
| 3   | 0.72                               |
| 4   | 0.66                               |
| 5   | 0.61                               |

Table E-5 Applied Load Coefficient

| operating conditions     |                 | applied load coefficient f <sub>w</sub> |
|--------------------------|-----------------|---|
| loading                  | velocity        |   |
| no shock and vibration   | 15m/min or less | 1.0~1.5                                 |
| low shock and vibration  | 40m/min or less | 1.5~2.0                                 |
| high shock and vibration | 40m/min or less | 2.0~3.5                                 |

Since the slide rotary bush is used in combined linear and rotary motion, the life time is obtained using Equations (2) and (3).

### When linear and rotary motions are combined

$$L_h = \frac{10^6 \cdot L}{60 \sqrt{(dm \cdot n)^2 + (10 \cdot S \cdot n_1)^2 / dm}} \dots \dots (2)$$

L<sub>h</sub>: life time (hr) S: stroke length (mm) n: revolutions per minute (rpm) n<sub>1</sub>: number of cycles per minute (cpm) dm: ball pitch diameter (mm) ≈ 1.07dr (dr is the inner contact diameter of FR type)

### When only linear motion is involved

$$L_h = \frac{10^6 \cdot L}{600 \cdot S \cdot n_1 / (\pi \cdot dm)} \dots \dots \dots (3)$$

## HOUSING

NB Slide Rotary Bush FR type is manufactured with a properly controlled clearance between the shaft and the bush. When designing a custom housing, the recommended tolerance for the housing bore is H7 or H6. When rotational motion is involved anti-rotation tab option (Z) is recommended to prevent the bush from rotating within the housing.

Please refer to Table E-6 for the recommended dimensions of housing when using the anti-rotation tab. FRA type is provided with anti-rotation tab as standard feature.

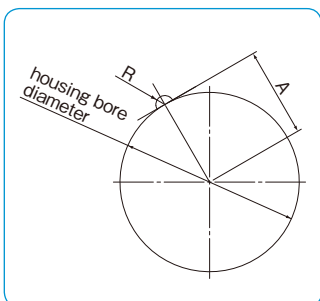

Table E-6

| part number | recommended dimensions |              |      |              |      |
|-------------|------------------------|--------------|------|--------------|------|
|             | housing bore diameter  |              | R    |              | A    |
|             | mm                     | tolerance mm | mm   | tolerance mm | mm   |
| FR20        | 32                     | +0.025       | 1.75 | +0.1<br>0    | 16   |
| FR25        | 40                     |              | 2.25 |              | 20   |
| FR30        | 45                     | 0            | 2.25 |              | 22.5 |
| FR40        | 60                     | +0.030       | 2.75 |              | 30   |
| FR50        | 80                     | 0            | 4    |              | 40   |

## USE AND HANDLING PRECAUTIONS

### Ball Drop

FR type is a set of a bush and shaft. Ball elements will drop out if the bush is removed from the shaft since the balls are not retained inside the cylinder. When FR bush must be removed from the shaft, please use a temporary shaft identical to the FR shaft diameter.

### Lubrication

The purpose of lubrication includes the reduction of friction among the rolling elements as well as between the rolling elements and the raceway, prevention of sintering, reduction of wear, and the prevention of rust. To maximize the performance of FR type, the lubricant type and lubrication method should be selected properly according to the operating conditions. The FR type is pre-lubricated with lithium soap based grease No. 0 for immediate use. Please relubricate with a similar type of grease depending on the operating conditions.

### Operating Temperature Range

FR type's allowable temperature range is from -20 to 80 degrees Celsius.

## APPLICATION EXAMPLES

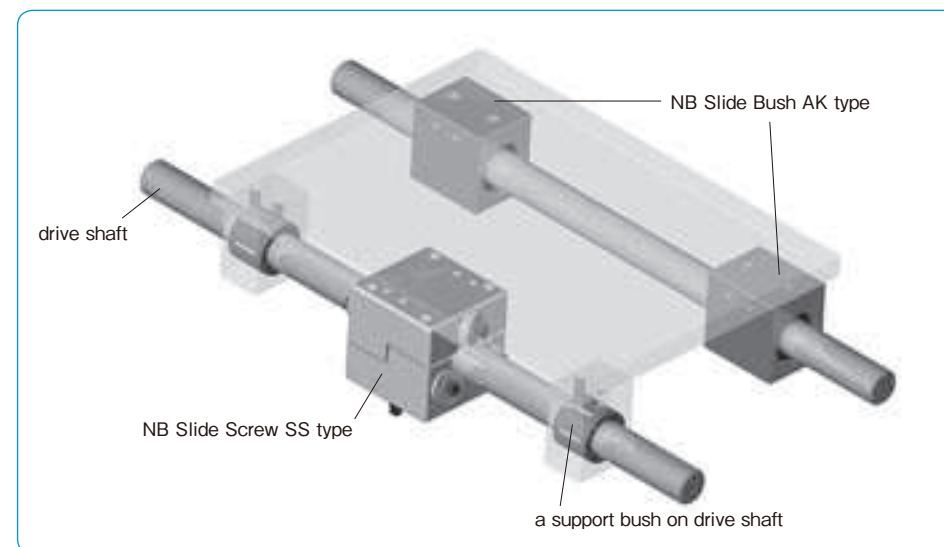
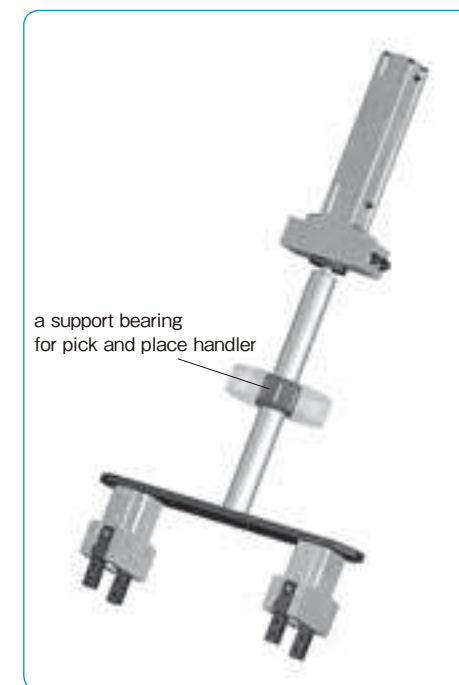
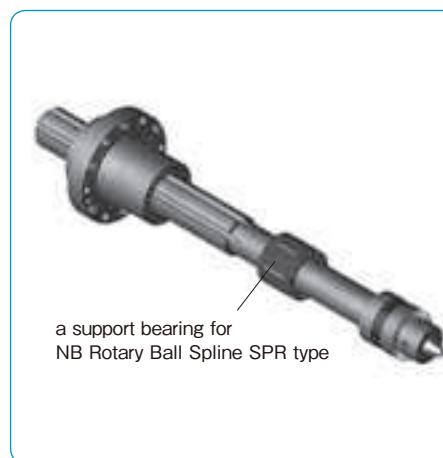

# FR TYPE

## part number structure

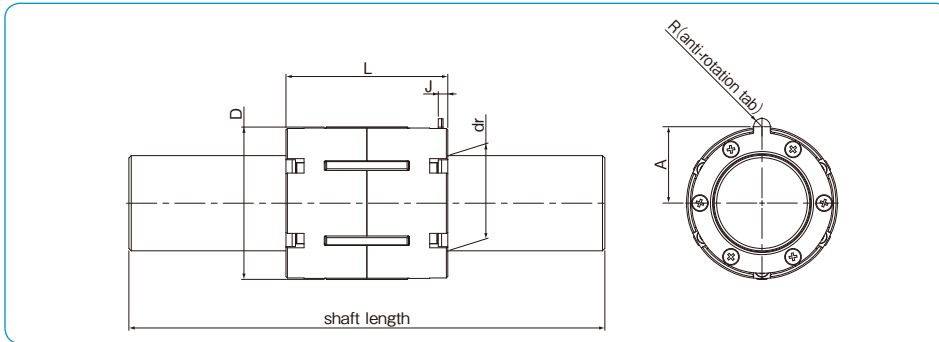
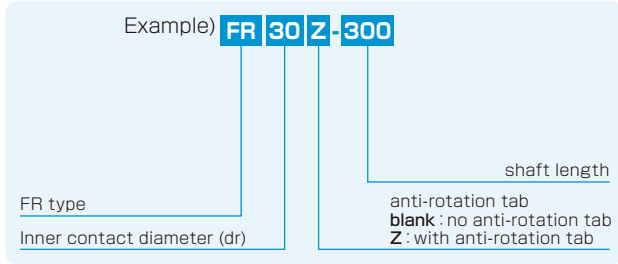

| part number | inner contact diameter<br>dr<br>mm | D <sup>*1</sup><br>mm | major dimensions |         |         |         |                   | basic load rating |       | allowable<br>revolutions<br>per minute | allowable<br>speed<br>m/min | mass <sup>*2</sup><br>g |
|-------------|------------------------------------|-----------------------|------------------|---------|---------|---------|-------------------|-------------------|-------|--|-----------------------------|-------------------------|
|             |                                    |                       | L<br>mm          | R<br>mm | A<br>mm | J<br>mm | dynamic<br>C<br>N | static<br>Co<br>N |       |  |                             |                         |
| FR20        | 20                                 | 32                    | 34               | 1.75    | 16      | 2       | 1,910             | 3,010             | 2,000 | 40                                     | 55                          |                         |
| FR25        | 25                                 | 40                    | 41               | 2.25    | 20      | 2.4     | 3,130             | 4,780             | 1,500 |  | 105                         |                         |
| FR30        | 30                                 | 45                    | 42               | 2.75    | 22.5    | 2.5     | 3,570             | 5,750             | 1,000 |  | 122                         |                         |
| FR40        | 40                                 | 60                    | 56               | 2.75    | 30      | 3       | 6,970             | 10,600            | 800   |  | 302                         |                         |
| FR50        | 50                                 | 80                    | 74               | 4       | 40      | 3       | 13,500            | 18,800            |       |  | 885                         |                         |

\*1 : excluding resin part  
\*2 : excluding shaft

# FRA TYPE

## part number structure

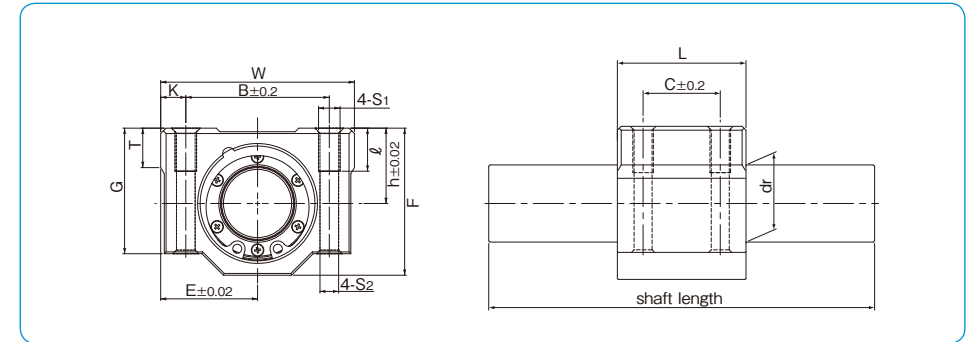
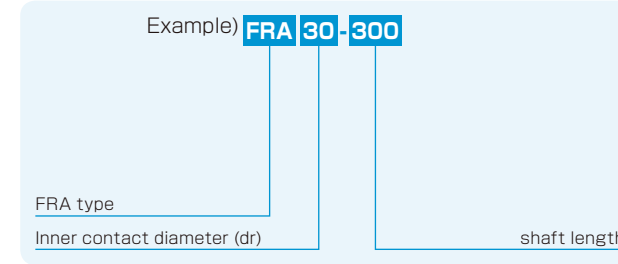

| part number | inner contact diameter<br>dr<br>mm | major dimensions |         |         |         |         |         |         |         |         |         |                      | basic load rating |                      |                   | allowable<br>revolutions<br>per minute | allowable<br>speed<br>m/min | mass <sup>*1</sup><br>g |                   |
|-------------|------------------------------------|------------------|---------|---------|---------|---------|---------|---------|---------|---------|---------|----------------------|-------------------|----------------------|-------------------|--|-----------------------------|-------------------------|-------------------|
|             |                                    | h<br>mm          | E<br>mm | W<br>mm | L<br>mm | F<br>mm | G<br>mm | T<br>mm | B<br>mm | C<br>mm | K<br>mm | S <sub>1</sub><br>mm | f<br>mm           | S <sub>2</sub><br>mm | dynamic<br>C<br>N |  |                             |                         | static<br>Co<br>N |
| FRA20       | 20                                 | 21               | 27      | 54      | 40      | 41      | 35      | 11      | 40      | 25      | 7       | M6                   | 12                | 5.2                  | 1,910             | 3,010                                  | 2,000                       | 40                      | 170               |
| FRA25       | 25                                 | 26               | 38      | 76      | 50      | 51.5    | 42      | 12      | 54      | 30      | 11      | M8                   | 18                | 7                    | 3,130             | 4,780                                  | 1,500                       |                         | 360               |
| FRA30       | 30                                 | 30               | 39      | 78      | 50      | 59.5    | 49      | 15      | 58      | 30      | 10      |                      |                   |                      | 3,570             | 5,750                                  | 1,000                       |                         | 420               |
| FRA40       | 40                                 | 40               | 51      | 102     | 65      | 78      | 62      | 20      | 80      | 40      | 11      | M10                  | 25                | 8.7                  | 6,970             | 10,600                                 | 800                         |                         | 950               |
| FRA50       | 50                                 | 52               | 61      | 122     | 84      | 102     | 80      | 25      | 100     | 50      | 11      |                      |                   |                      | 13,500            | 18,800                                 |                             |                         | 2,120             |

\*1 : excluding shaft