

SLIDE WAY
SLIDE TABLE
**MINIATURE
SLIDE**
GONIO WAY

SLIDE WAY

The NB slide way is a non-recirculating linear motion bearing utilizing precision rollers. It is used primarily in optical and measurement equipment where high precision movement is required.

STRUCTURE AND ADVANTAGES

The NB slide way NV type comprises precisely ground rails and R-retainers with built-in STUDROLLERS and precision rollers. The rails have been optimally designed so that the STUDROLLERS move smoothly, and the STUDROLLERS and precision rollers incorporated in the R-retainers enable slip-free operation between the raceway surface and the rollers resulting in motion with minimal frictional resistance. SV and SVW types consist of precision ground rails and precision caged-rollers. Since caged-rollers do not recirculate, there is only a minimum frictional resistance fluctuation. Also, there is a minimum difference between the static and dynamic frictional resistances.

Non-slip!

STUDROLLER System (Rivet Roller Structure)

The STUDROLLER system is based on a new concept to provide complete prevention of roller cage slippage during operation. This system permits usage in all orientations and positions.

Figure G-1 STUDROLLER System



Suitable for Minute Motion

Because the frictional resistance is extremely small and there is only little difference between the static and dynamic frictional resistances, the NB slide way is well suited for minute motion, resulting in highly accurate linear movement.

Low-Speed Stability

Since the frictional resistance fluctuation is small even under low-load conditions, stable motion is obtained at from low to high speeds.

High Rigidity and High Load Capacity

Compared to the ball elements, the rollers provide a larger contact area and less elastic deformation, thus the NB slide way has high rigidity and high load capacity. With new NV rail design, the roller contact area is increased by 30 to 58% (Figure G-2). The number of effective rollers is increased by narrowing the roller pitch. Thus, the NV type has the load rating that is 1.3 to 2.5 times that of the SV type.

Low Noise

The slide way never produces recirculation noise nor roller-contact noise due to a use of roller cage, resulting in quiet motion.

All Stainless Steel Type Available

The anti-corrosion SVS/SVWS slide ways have all stainless steel components, making them ideal for use in clean room applications.

Figure G-2 Roller Contact Profile

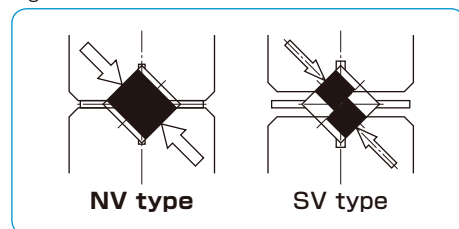

Figure G-3 Structure of NV type

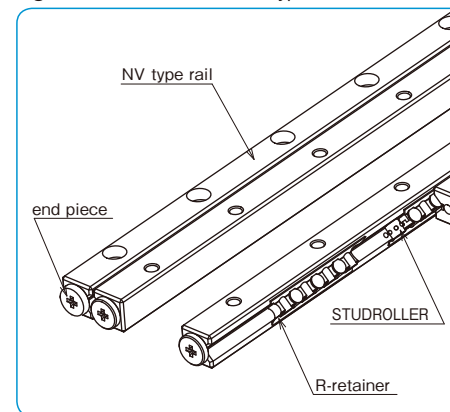
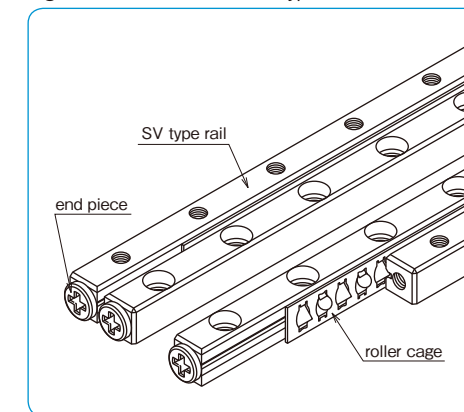

Figure G-4 Structure of SV type



※To the NV type, fastening plates are attached for the purpose of maintaining the center position of the R-retainer before assembly. Please see Installation Procedure on page G-7 and remove the fastening plates before use.

TYPES



The NV slide way consists of a set of four rails, two R-retainers, and eight end pieces. It permits flexible design of the table which will best suit your application.

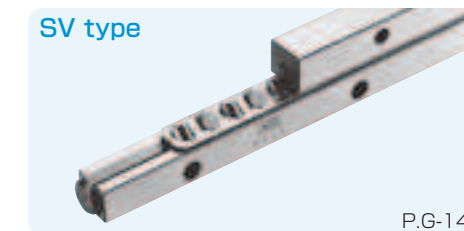

The SV slide way consists of a set of four rails, two R type roller cages, which have precision rollers in a cross arrangement, and eight end pieces. The all stainless steel option makes it suitable for use in corrosive environments.

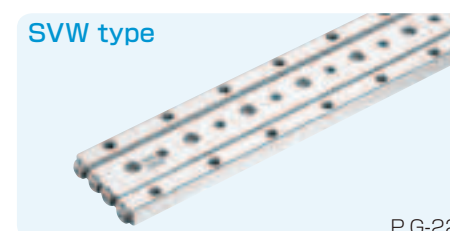

The SVW slide way consists of two SV-type rails, one W type rail, two R type roller cages, and eight end pieces. The use of a W-type rail serves for a compact design. The SVWS type is also available with all stainless steel components.

ACCURACY

The accuracy of the slide way is represented as parallelism measured across the full length with a method shown in Figure G-6. It is classified as high (blank), precision (P), or ultra precision (UP). Special accuracies can also be accommodated. Please contact NB for details.

Figure G-5 Parallelism

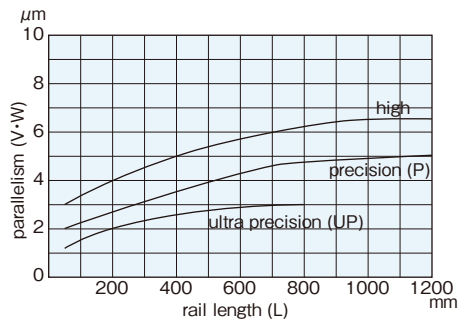
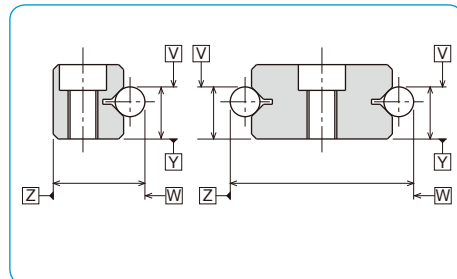

Figure G-6 Accuracy Measurement Method



Ultra precision grade is available from size 1 to size 9.

RATED LIFE

The life of the slide way and the slide table is calculated with the following equations:

Rated Life

$$L = \left(\frac{f_T \cdot C}{f_W \cdot P} \right)^{10} \cdot 50$$

L: rated life (km) f_T: temperature coefficient f_W: applied load coefficient
 C: basic dynamic load rating (N) P: applied load (N)
 ※ Please refer to page Eng-5 for the coefficients.

Life Time

$$L_h = \frac{L \cdot 10^3}{2 \cdot l_s \cdot n \cdot 60}$$

L_h: life time (hr) l_s: stroke length (m)
 n: number of cycles per minute (cpm)

LOAD RATING

The load rating for the slide way is obtained using the equations listed in Table G-1.

Table G-1 Load Rating

condition	single-rail usage	single-rail vertical usage	double-rail parallel usage
direction of load			
basic dynamic load rating C	$C = \left(2P \left(\frac{Z}{2} - 1 \right) \right)^{\frac{1}{36}} \cdot \left(\frac{Z}{2} \right)^{\frac{3}{4}} \cdot C_1$	$C = \left(2P \left(\frac{Z}{2} - 1 \right) \right)^{\frac{1}{36}} \cdot \left(\frac{Z}{2} \right)^{\frac{3}{4}} \cdot 2^{\frac{7}{9}} \cdot C_1$	
basic static load rating C ₀	$C_0 = \frac{Z}{2} \cdot C_{01}$	$C_0 = \frac{Z}{2} \cdot C_{01} \cdot 2$	
allowable load F	$F = \frac{Z}{2} \cdot F_1$	$F = \frac{Z}{2} \cdot F_1 \cdot 2$	

C: basic dynamic load rating (N) C₀: basic static load rating (N) F: allowable load (N) C₁: basic dynamic load rating per roller (N)
 C₀₁: basic static load rating per roller (N) F₁: allowable load per roller (N)
 Z: number of rollers per cage Z/2: number of effective rollers (round down to whole number) P: roller pitch (mm)

The load rating of the NV type differs depending on the direction of the load.

Table G-2 Change of Load Rating Corresponding to Load Direction

basic dynamic load rating	normal vertical direction	1.0×C
	horizontal direction	0.85×C
	reverse vertical direction	0.7×C
basic static load rating	normal vertical direction	1.0×C ₀
	horizontal direction	0.85×C ₀
	reverse vertical direction	0.7×C ₀

※ There may be a difference depending on the size. Please contact NB for details.
 Consideration has been given to holes for STUDROLLERS in the raceway surface in calculation of load ratings.

Figure G-7 Direction of Load

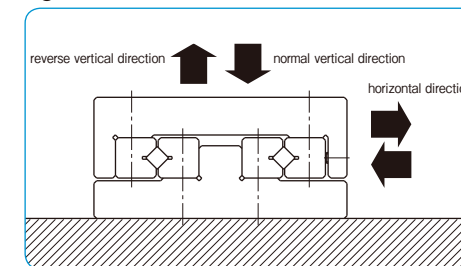

R·RS TYPE

— Standard Roller Cage —
 part number structure

example **RS 6 - 15Z**

specification
 R: standard roller
 RS: stainless steel roller

number of rollers
 size

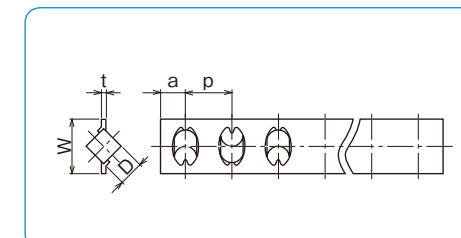

part number		D	t	W	p	a	C ₁	C ₀₁	F ₁
standard	anti-corrosion	mm	mm	mm	mm	mm	N	N	N
R 1	RS1	1.5	0.2	3.8	2.5	2	154	119	39.8
R 2	RS2	2	0.3	5.6	4	2.5	360	293	97.8
R 3	RS3	3	0.4	7.6	5	3	824	649	216
R 4	RS4	4	0.4	10.4	7	4.5	1,660	1,320	442
R 6	RS6	6	0.7	14	8.5	5.5	3,840	2,960	987
R 9	—	9	0.7	19	14	7.5	9,330	7,070	2,350
R12	—	12	1.0	25	20	10	18,900	14,500	4,840

cage material: stainless steel C₁: dynamic load rating per roller C₀₁: static load rating per roller
 F₁: allowable load per roller

RA·RAS TYPE

— Aluminum Roller Cage —
 part number structure

example **RAS 6 - 15Z**

specification
 RA: standard roller
 RAS: stainless steel roller

number of rollers
 size

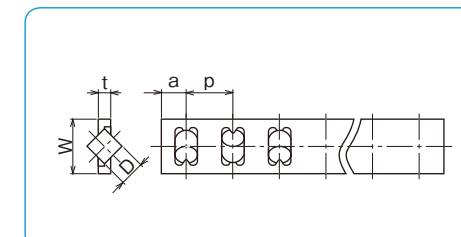

part number		D	t	W	p	a	C ₁	C ₀₁	F ₁
standard	anti-corrosion	mm	mm	mm	mm	mm	N	N	N
RA3	RAS3	3	1.2	7.6	5	3	824	649	216
RA4	RAS4	4	1.4	10.4	7	4.5	1,660	1,320	442
RA6	RAS6	6	2.1	14	8.5	5.5	3,840	2,960	987
RA9	—	9	3.0	20	14	7.5	9,330	7,070	2,350

cage material: aluminum alloy C₁: dynamic load rating per roller C₀₁: static load rating per roller
 F₁: allowable load per roller

STROKE

Please contact NB for a non-standard stroke length for the NV type. When the stroke of SV type or SVW type is changed, the stroke length must be determined and the load rating should be re-estimated as follows.

Stroke of SV type, SVW type

When the slide way moves along the rail, the cage moves half the distance traveled by the slide way in the same direction. Therefore, although the work may be fixed on the table, the distance between the load center and the cage center will change. To achieve stable accuracy, determine the stroke and the length of the rail as follows.

Figure G-8

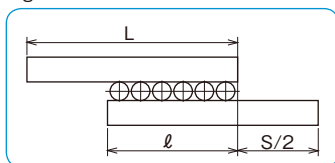

Rail Length (L)
When the stroke is 400mm or over
 $S \leq L/1.5$
When the stroke is less than 400 mm,
 $S \leq L$
l: cage length (mm) S: stroke (mm)
L: rail length (mm)

Cage length (l)
 $l \leq L - \frac{S}{2}$
Number of rollers (Z)
 $Z = \frac{l - 2a}{p} + 1$
a,p: Please refer to roller cage dimensions
(page G-5)

LUBRICATION AND DUST PREVENTION

Lubrication

The slide way is pre-lubricated with lithium soap-based grease prior to shipment for immediate use. Make sure to relubricate with a similar type of grease periodically according to the operating conditions. NB also provides low dust generation grease. Please refer to page Eng-39 for details.

Dust Prevention

Foreign particles or dust in the slide way affects the motion accuracy and shortens the life time. In a harsh environment please provide side covers for dust prevention. (refer to Figure G-9)

Figure G-9 Example of Dust Prevention Mechanism

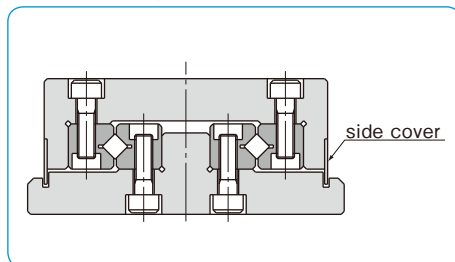

MOUNTING

Example

Figure G-10 NV type, SV type

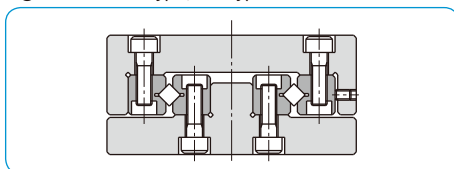
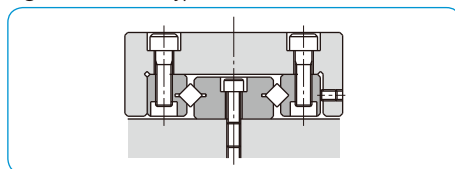

Figure G-11 SVW type



Accuracy of Mounting Surface

To maximize the performance of the NB slide way, it is recommended that the accuracy of the mounting surface to be equal to or greater than the degree of parallelism of the slide way.

- Parallelism of surface 1 against surface A
- Perpendicularity of surface 2 against surface A
- Parallelism of surface 3 against surface B
- Perpendicularity of surface 4 against surface B
- Parallelism of surface 2 against surface C
- Parallelism of surface 4 against surface C

Figure G-12 Accuracy of Mounting Surface

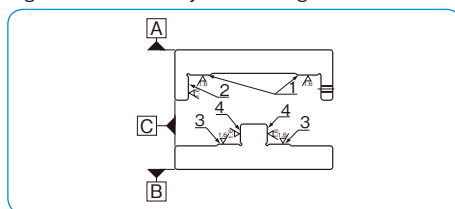

INSTALLATION PROCEDURE OF NV TYPE

Installation Procedure

※Please read "Use and Handling Precautions" before installation.

- (1) Remove burrs, scratches, and dust from the rail-mounting surface of the bed and the table, be careful to prevent contamination during assembly.
- (2) Apply low-viscosity oil to the contact surfaces, and align the bed and the table. (Figure G-13a)
- (3) Set the reference surface onto the mounting surface with the rails fastened. Set the table in the center position, and tighten the adjustment screws lightly so that almost no gap remains. (Figure G-13b)
- (4) Keep the table in the center, tighten the rail mounting bolts lightly, loosen the end pieces of both ends, and remove the fastening plates. Following this, lightly retighten the end pieces.
- (5) While maintaining the conditions of (4), gently move the assembly through its stroke to check if the maximum stroke is secured, and if there is no irregularity.
- (6) Move the table to the center and tighten only the adjustment screws on the R-retainer with the recommended torque shown in Table G-3. (Figure G-13c)
- (7) Gently move the table to one stroke end, and check that the table has surely come into contact with the external mechanical stopper. Following this, tighten the adjustment screws in the same manner as (6). (Figure G-13d)
- (8) Move the table to the opposite stroke end, and tighten in the same manner as (6). (Figure G-13e)
- (9) Fasten the mounting screws on rails 1, 2, and 3 by tightening with the recommended torque shown in Table G-4. (Figure G-13f)
- (10) Set the dial indicators to the center of the table and to the side (reference surface) of the table. (Figure G-13g)
- (11) Perform the final preload adjustment. While moving the table back and forth, repeat steps (6) to (8) until the dial indicators show a minimum deviation.
- (12) Fasten rail 4 securely with the recommended torque. As for the adjustment screws, successively tighten the mounting screws on the R-retainer by moving the table.
- (13) Recheck the motion accuracy while moving the table.
- (14) Tighten the end pieces finally.

Figure G-13 Installation Method

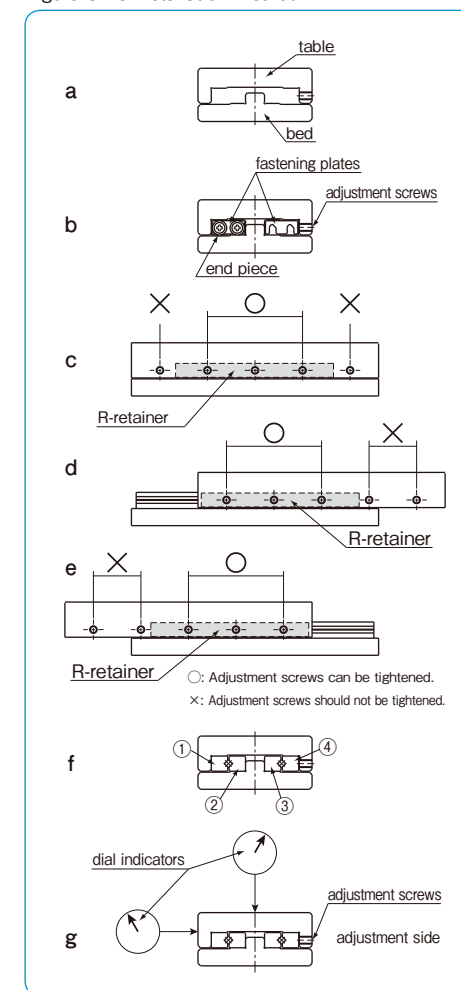

INSTALLATION PROCEDURE OF SV TYPE

Installation Procedure

- Remove burrs, scratches, and dust from the rail-mounting surface of the bed and the table, be careful to prevent contamination during assembly.
- Apply low-viscosity oil to contact surfaces. Attach rails ①-③ by tightening screws with the recommended torque (Table G-4). (Figure G-14a)
- Temporarily attach rail ④ on the adjustment side. (Figure G-14b)
- Remove end pieces on one end. Carefully insert roller cages between rails. (Figure G-14c)
- Re-attach end pieces.
- Move the table slowly to each stroke end to position roller cages at the center of the rails.
- Set the dial indicators to the center of the table and to the side (reference surface) of the table. (Figure G-14d)
- Move the table to one stroke end. Lightly tighten adjustment screws on the roller cage. (Figure G-14e)
- Move the table to the opposite stroke end. Similarly lightly tighten adjustment screws on the roller cage. (Figure G-14f)
- Move table to the center and lightly tighten center adjustment screws. (Figure G-14g)
- Repeat steps (8) ~ (10) until the indicators show a minimum deviation. Please do not apply an excessive preload.
- Make final adjustment of preload. Repeat steps (8) ~ (10) and tighten the adjustment screws with the recommended torque listed in Table G-3.
- Fasten the rail ④ securely with the recommended torque. As with the adjustment screws, successively tighten the mounting screws by moving the table.

Figure G-14 Installation Method

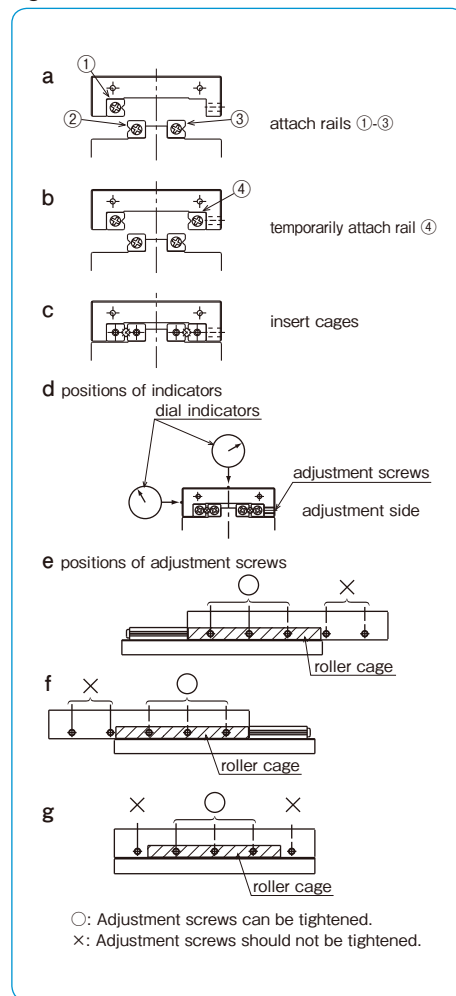

Table G-3 Recommended Torque for Adjustment Screw Unit/N · m

part number	size	torque
SV1	M2	0.008
NV2, SV2	M3	0.012
NV3, SV3	M4	0.05
NV4, SV4	M4	0.08
NV6, SV6	M5	0.20
NV9, SV9	M6	0.40

Table G-4 Recommended Torque for Mounting screw Unit/N · m

size	torque
M2	0.4
M3	1.4
M4	3.2
M5	6.6
M6	11.2
M8	27.6

(for steel alloy screw)

SPECIAL MOUNTING SCREW BT TYPE

To install the slide way using its counterbore, use of the BT type special mounting screw is recommended.

Figure G-15 Special Mounting Screw

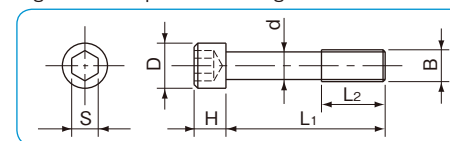

Table G-5 Special Mounting Screw

part number	B	d	D	H	L1	L2	S	applicable size
BT 3	M3	2.3	5	3	12	5	2.5	NV 3, SV 3
BT 4	M4	3.1	5.8	4	15	7	3	NV 4, SV 4
BT 6	M5	3.9	8	5	20	8	4	NV 6, SV 6
BT 9	M6	4.6	8.5	6	30	12	5	NV 9, SV 9
BT12	M8	6.25	11.3	8	40	17	6	NV12, SV12

USE AND HANDLING PRECAUTIONS

Careful Handling

Dropping the slide way causes the rolling elements to make dents in the raceway surface. This will prevent smooth motion and will also affect accuracy. Be sure to handle the product with care. The NV type is packaged as a set of rails and R-retainers. Do not separate or disassemble until assembly/installation is completed. Precision is not guaranteed if disassembled.

Fastening Plates

For the NV type, fastening plates are attached at both end faces of the rails to maintain the R-retainer center position prior to assembly. The fastening plates are not required after the NV type is mounted to a table and bed, however, when removal of the NV type is necessary such as when it will be reassembled, be sure to return the R-retainer to the proper center position, secure the fastening plates with the end pieces, and then remove the NV type.

Specified Allowable Stroke

For the NV type, exceeding the specified stroke (over-stroke) shall cause the raceway surface of the rail to be damaged and the performance of the STUDROLLER to drastically deteriorate. Be sure to provide external mechanical stoppers and use the product within 80% of the specified allowable stroke.

Adjustment

Using the product with insufficient accuracy of the mounting surface or before adjusting the preload will cause the motion accuracy of the product to drop and will have a negative influence upon product life and accuracy. Make sure to assemble, install, and adjust the product with care.

Caution against Excess Preload

It is essential to give preload on the Slide Way products in order to assure rigidity and accuracy. However, excess preload causes damage on the raceways and roller cages/R-retainers.

On installation, please follow the installation procedure and recommended torque on page G-8.

Operating Temperature

The NV type uses resin parts. Please use the product in environments that are lower than 80°C.

Use as a Set

The accuracy of the rails has been matched within each set. Note that the accuracy will be affected when the rails of different sets are combined.

Allowable Load

The allowable load is a load under which the sum of elastic deformations of the rolling element and the raceway in the contact area subject to the maximum contact stress is small enough to guarantee smooth rolling movement. When very smooth and highly accurate linear motion is required, make sure to use the product within the allowable load.

Cage Slippage

In the SV/SVW type, when used under high-speed, unbalanced-load, or vibrational conditions, cage slippage may occur. The stroke length should be determined with sufficient margin, and an excessive preload should be avoided.

End Pieces

End pieces are attached to each end of the slide way to prevent removal of the cage. Do not use them as a mechanical stopper.

Knock Pin Hole

When using SVW type knock pin holes to attach a slide way, please do the hole-machining on the mounting surface after attaching the W type rail. After machining, remove the chips completely and wash as required.

NV TYPE

-NV2/NV3/NV4-

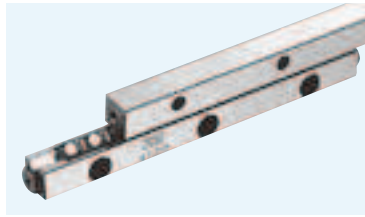

part number structure

example **NV 2 150 41Z UP**

NV type

size

rail length

accuracy grade
blank: high
P: precision
UP: ultra precision

number of rollers

part number	stroke ST mm	roller diameter D mm	number of rollers Z	major dimensions												
				L mm	A mm	B mm	C mm	M×P mm	N mm	E mm						
NV2030- 5Z	18	2	5	30	12	6	5.7	1×15	7.5	2.5						
2045- 9Z	25		9	45				2×15								
2060- 15Z	30		15	60				3×15								
2075- 19Z	40		19	75				4×15								
2090- 23Z	50		23	90				5×15								
2105- 27Z	65		27	105				6×15								
2120- 33Z	70		33	120				7×15								
2135- 37Z	80		37	135				8×15								
2150- 41Z	90		41	150				9×15								
2165- 47Z	95		47	165				10×15								
2180- 51Z	100		51	180				11×15								
NV3050- 9Z	25	3	9	50	18	8	8.65	1×25	12.5	3.5						
3075- 13Z	48		13	75				2×25								
3100- 19Z	60		19	100				3×25								
3125- 23Z	83		23	125				4×25								
3150- 29Z	90		29	150				5×25								
3175- 35Z	103		35	175				6×25								
3200- 41Z	113		41	200				7×25								
3225- 43Z	150		43	225				8×25								
NV4080- 9Z	60		4	9				80			22	11	10.65	1×40	20	4.5
4120- 17Z	75			17				120						2×40		
4160- 23Z	105			23				160						3×40		
4200- 29Z	130	29		200	4×40											
4240- 37Z	143	37		240	5×40											
4280- 43Z	170	43		280	6×40											

The basic static load rating is the value at the center of the stroke.

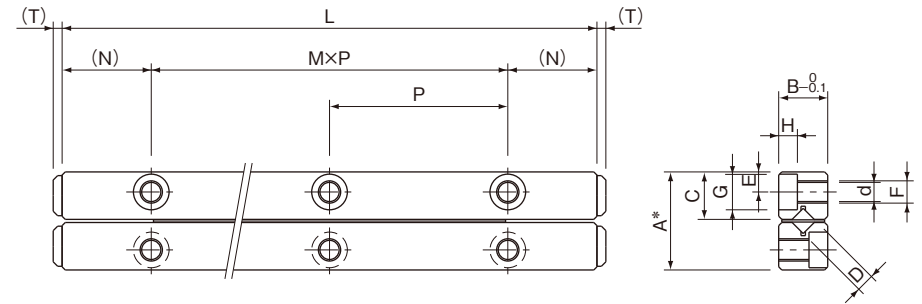

High grade: A-0.2 Precision grade (P): A-0.1 Ultra Precision grade (UP): A-0.0
One set consists of 4 rails, 2 R-retainers, and 8 end pieces.

F	d mm	G mm	H mm	T mm	basic load rating		allowable load F N	mass (one set) g	size
					dynamic C N	static Co N			
M3	2.55	4.4	2	2	1,360	1,520	500	33	2030
					2,330	3,050	1,010	49	2045
					3,990	6,110	2,030	62	2060
					4,740	7,630	2,540	74	2075
					5,460	9,160	3,050	91	2090
					6,160	10,600	3,560	103	2105
					6,830	12,200	4,070	120	2120
					7,490	13,700	4,580	132	2135
					8,130	15,200	5,090	149	2150
					9,370	18,300	6,110	161	2165
					9,970	19,800	6,620	174	2180
M4	3.3	6	3.1	2	6,150	8,060	2,680	97	3050
					8,440	12,100	4,030	140	3075
					12,500	20,100	6,720	192	3100
					14,400	24,200	8,060	245	3125
					16,300	28,200	9,410	290	3150
					19,800	36,300	12,100	337	3175
					21,500	40,300	13,400	385	3200
					23,200	44,300	14,700	434	3225
					12,100	15,700	5,250	265	4080
					20,700	31,500	10,500	400	4120
					28,500	47,200	15,700	530	4160
M5	4.3	8	4.2	2	32,100	55,100	18,300	660	4200
					39,000	70,900	23,600	800	4240
					45,600	86,600	28,800	930	4280

1N=0.102kgf

NV TYPE

-NV6/NV9/NV12-

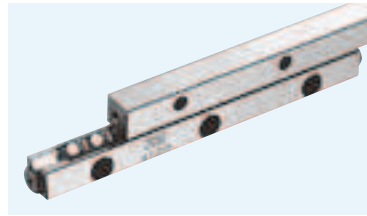

part number structure

example **NV 6 200 19Z UP**

NV type

size

rail length

accuracy grade
blank: high
P: precision
UP: ultra precision
 The UP grade is not available for NV 12

number of rollers

part number	stroke ST mm	roller diameter D mm	number of rollers Z	major dimensions						
				L mm	A mm	B mm	C mm	M×P mm	N mm	E mm
NV6100- 9Z	63	6	9	100	31	15	15.15	1×50	25	6
6150- 15Z	85		15	150				2×50		
6200- 19Z	135		19	200				3×50		
6250- 25Z	158		25	250				4×50		
6300- 31Z	180		31	300				5×50		
6350- 35Z	230		35	350				6×50		
6400- 39Z	275		39	400				7×50		
NV9200- 13Z	120	9	13	200	44	22	21.5	1×100	50	9
9300- 21Z	170		21	300				2×100		
9400- 29Z	220		29	400				3×100		
9500- 35Z	300		35	500				4×100		
NV12300- 15Z	180	12	15	300	58	28	28.5	2×100	50	12
12400- 21Z	230		21	400				3×100		
12500- 27Z	280		27	500				4×100		
12600- 31Z	380		31	600				5×100		

The basic static load rating is the value at the center of the stroke.

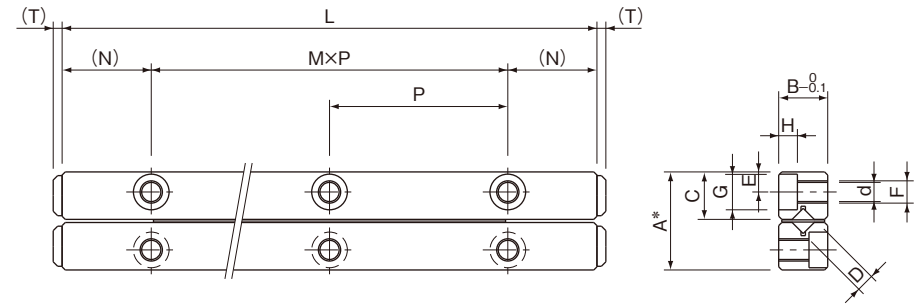

High grade: A-0.2 Precision grade (P): A-0.1 Ultra Precision grade (UP): A-0.0
 One set consists of 4 rails, 2 R-retainers, and 8 end pieces.

F	d	G	H	T	basic load rating		allowable load F N	mass (one set) g	size
					dynamic C N	static Co N			
M6	5.2	9.5	5.2	3	29,600	37,500	12,500	650	6100
					50,900	75,100	25,000	970	6150
					60,600	93,900	31,300	1,300	6200
					69,800	112,000	37,500	1,620	6250
					87,400	150,000	50,100	1,940	6300
					95,800	169,000	56,300	2,360	6350
					104,000	187,000	62,600	2,780	6400
M8	6.8	10.5	6.2	4	96,000	128,000	42,600	2,720	9200
					143,000	213,000	71,100	4,080	9300
					186,000	298,000	99,500	5,440	9400
					226,000	384,000	128,000	6,790	9500
					228,000	317,000	105,000	6,770	12300
M10	8.5	13.5	8.2	4	271,000	396,000	132,000	9,040	12400
					352,000	555,000	185,000	11,300	12500
					391,000	635,000	211,000	13,560	12600

1N=0.102kgf

SV TYPE

-SV1/SV2-

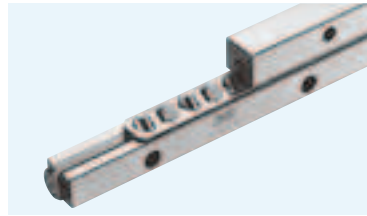

part number structure

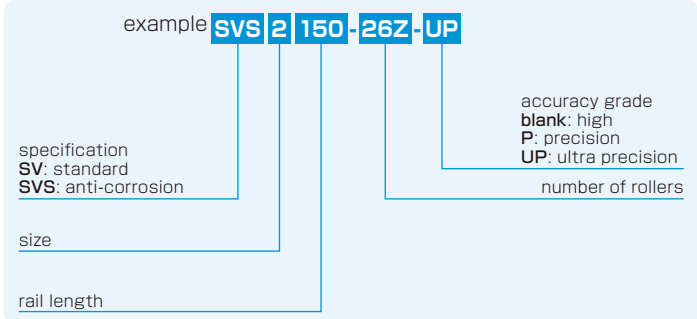

※Stainless steel rollers are used for anti-corrosion type. (refer to page G-5)

part number		stroke	roller diameter D mm	number of rollers Z	L mm	A mm	B mm	C mm				
standard	anti-corrosion	ST mm										
SV 1020-5Z	SVS 1020-5Z	12	1.5	5	20	8.5	4	3.8				
1030-7Z	1030-7Z	20		7	30							
1040-10Z	1040-10Z	27		10	40							
1050-13Z	1050-13Z	32		13	50							
1060-16Z	1060-16Z	37		16	60							
1070-19Z	1070-19Z	42		19	70							
1080-21Z	1080-21Z	50		21	80							
SV 2030-5Z	SVS 2030-5Z	18		2	5				30	12	6	5.5
2045-8Z	2045-8Z	24			8				45			
2060-11Z	2060-11Z	30	11		60							
2075-13Z	2075-13Z	44	13		75							
2090-16Z	2090-16Z	50	16		90							
2105-18Z	2105-18Z	64	18		105							
2120-21Z	2120-21Z	70	21		120							
2135-23Z	2135-23Z	84	23		135							
2150-26Z	2150-26Z	90	26		150							
2165-29Z	2165-29Z	95	29		165							
2180-32Z	2180-32Z	100	32		180							

※Maximum Rail Length (standard type only)

part number	Max. length
SV1	200mm
SV2	450mm

※Please contact NB for details.

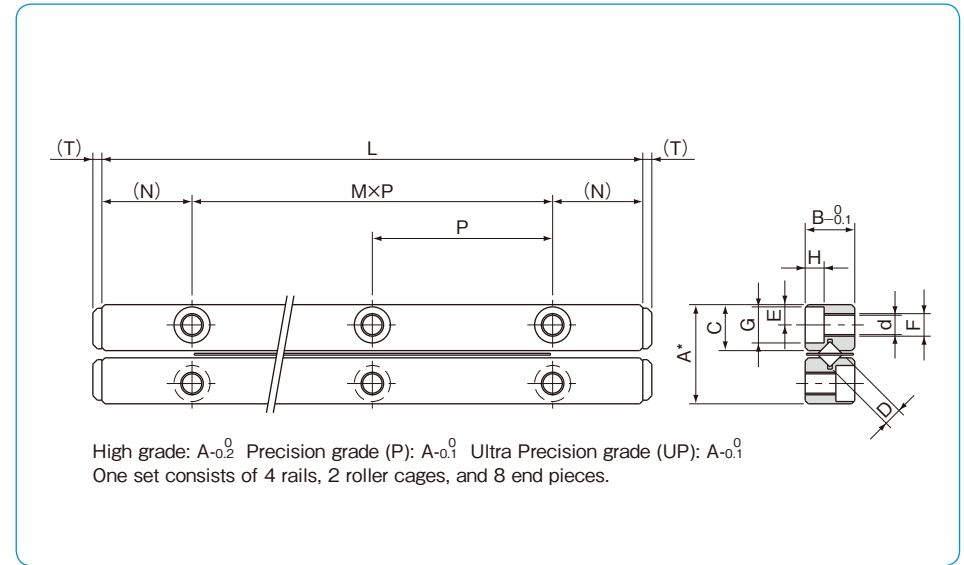

major dimensions								basic load rating			allowable load F N	mass (one set) g	size
M × P mm	N mm	E mm	F	d mm	G mm	H mm	T mm	dynamic C N	static Co N				
1 × 10	5	1.8	M2	1.65	3	1.4	0.8	464	476	158	11	1020	
2 × 10								641	714	237	14	1030	
3 × 10								959	1,190	396	18	1040	
4 × 10								1,100	1,420	475	22	1050	
5 × 10								1,380	1,900	633	26	1060	
6 × 10								1,510	2,140	712	30	1070	
7 × 10								1,650	2,380	792	34	1080	
1 × 15	7.5	2.5	M3	2.55	4.4	2	2	1,090	1,170	390	28	2030	
2 × 15								1,900	2,340	780	42	2045	
3 × 15								2,270	2,930	976	55	2060	
4 × 15								2,620	3,510	1,170	69	2075	
5 × 15								3,280	4,680	1,560	83	2090	
6 × 15								3,590	5,270	1,750	96	2105	
7 × 15								3,900	5,860	1,950	110	2120	
8 × 15								4,210	6,440	2,140	123	2135	
9 × 15								4,790	7,610	2,530	137	2150	
10 × 15								5,080	8,200	2,730	151	2165	
11 × 15								5,640	9,370	3,120	165	2180	

1N=0.102kgf

SV TYPE

-SV3/SV4-

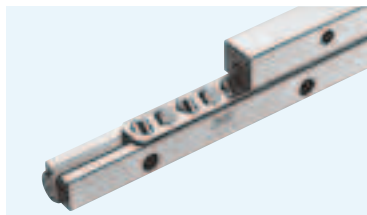

part number structure

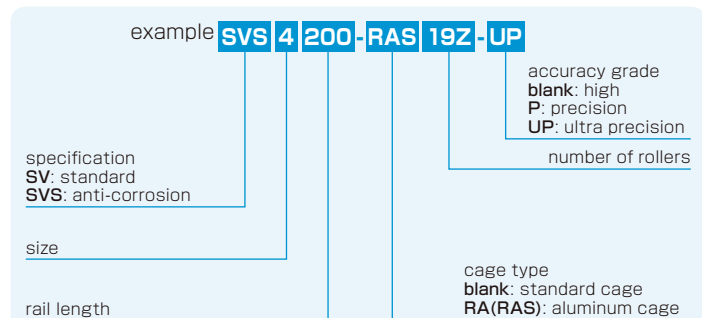

※Stainless steel rollers are used for anti-corrosion type. (refer to page G-5)

part number		stroke	roller diameter D mm	number of rollers Z	L mm	A mm	B mm	C mm
standard	anti-corrosion	ST mm						
SV 3050-7Z	SVS 3050-7Z	28	3	7	50	18	8	8.3
3075-10Z	3075-10Z	48		10	75			
3100-14Z	3100-14Z	58		14	100			
3125-17Z	3125-17Z	78		17	125			
3150-21Z	3150-21Z	88		21	150			
3175-24Z	3175-24Z	105		24	175			
3200-28Z	3200-28Z	115		28	200			
3225-31Z	3225-31Z	135		31	225			
3250-35Z	3250-35Z	145		35	250			
3275-38Z	3275-38Z	165		38	275			
3300-42Z	3300-42Z	175		42	300			
3325-45Z	3325-45Z	195		45	325			
3350-49Z	3350-49Z	205		49	350			
SV 4080-7Z	SVS 4080-7Z	58	4	7	80	22	11	10.2
4120-11Z	4120-11Z	82		11	120			
4160-15Z	4160-15Z	105		15	160			
4200-19Z	4200-19Z	130		19	200			
4240-23Z	4240-23Z	150		23	240			
4280-27Z	4280-27Z	175		27	280			
4320-31Z	4320-31Z	200		31	320			
4360-35Z	4360-35Z	225		35	360			
4400-39Z	4400-39Z	250		39	400			
4440-43Z	4440-43Z	270		43	440			
4480-47Z	4480-47Z	295		47	480			

※Maximum Rail Length (standard type only)

part number	Max. length
SV3	700mm
SV4	700mm

※Please contact NB for details.

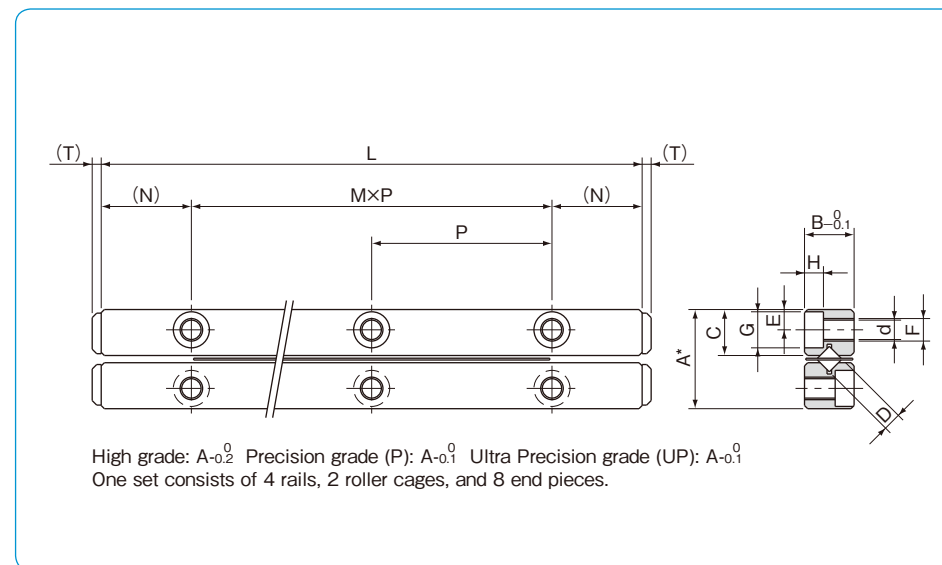

major dimensions								basic load rating		allowable load F N	mass (one set) g	size
M×P mm	N mm	E mm	F	d mm	G mm	H mm	T mm	dynamic C N	static Co N			
1×25	12.5	3.5	M4	3.3	6	3.1	2	3,490	3,890	1,290	94	3050
2×25								5,230	6,490	2,160	135	3075
3×25								6,810	9,080	3,020	187	3100
4×25								7,560	10,300	3,450	234	3125
5×25								9,000	12,900	4,320	281	3150
6×25								10,300	15,500	5,180	327	3175
7×25								11,700	18,100	6,040	374	3200
8×25								12,300	19,400	6,480	421	3225
9×25								13,600	22,000	7,340	468	3250
10×25								14,800	24,600	8,200	514	3275
11×25								16,000	27,200	9,070	561	3300
12×25								16,600	28,500	9,500	608	3325
13×25								17,800	31,100	10,300	655	3350
1×40	20	4.5	M5	4.3	8	4.2	2	7,110	7,920	2,640	255	4080
2×40								10,600	13,200	4,400	385	4120
3×40								13,800	18,400	6,160	510	4160
4×40								16,800	23,700	7,920	635	4200
5×40								19,700	29,000	9,680	770	4240
6×40								22,400	34,300	11,400	905	4280
7×40								25,100	39,600	13,200	1,020	4320
8×40								27,600	44,800	14,900	1,160	4360
9×40								30,200	50,100	16,700	1,280	4400
10×40								32,600	55,400	18,400	1,410	4440
11×40								35,000	60,700	20,200	1,540	4480

1N≒0.102kgf

SV TYPE

-SV6/SV9-

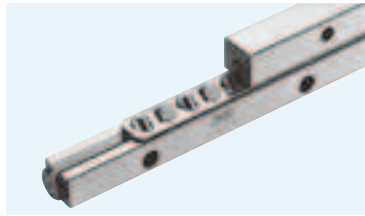

part number structure

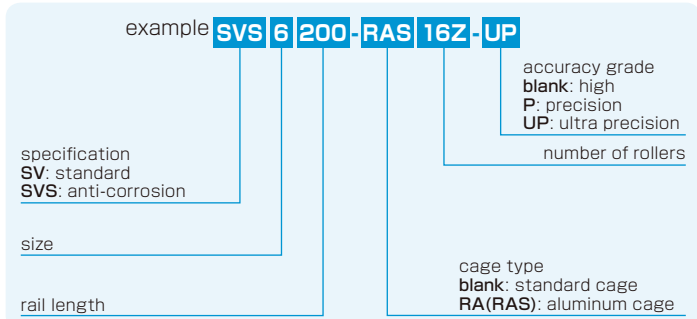

※Stainless steel rollers are used for anti-corrosion type. (refer to page G-5)

part number		stroke	roller diameter D mm	number of rollers Z	L mm	A mm	B mm	C mm
standard	anti-corrosion	ST mm						
SV 6100-8Z	SVS 6100-8Z	55	6	8	100	31	15	14.2
6150-12Z	6150-12Z	85		12	150			
6200-16Z	6200-16Z	120		16	200			
6250-20Z	6250-20Z	150		20	250			
6300-24Z	6300-24Z	185		24	300			
6350-28Z	6350-28Z	215		28	350			
6400-32Z	6400-32Z	245		32	400			
6450-36Z	6450-36Z	280		36	450			
6500-40Z	6500-40Z	310		40	500			
6600-49Z	6600-49Z	360		49	600			
SV 9200-10Z	—	115	9	10	200	44	22	20.2
9300-15Z	—	175		15	300			
9400-20Z	—	235		20	400			
9500-25Z	—	295		25	500			
9600-30Z	—	355		30	600			
9700-35Z	—	415		35	700			
9800-40Z	—	475		40	800			
9900-45Z	—	535		45	900			
91000-50Z	—	595		50	1,000			

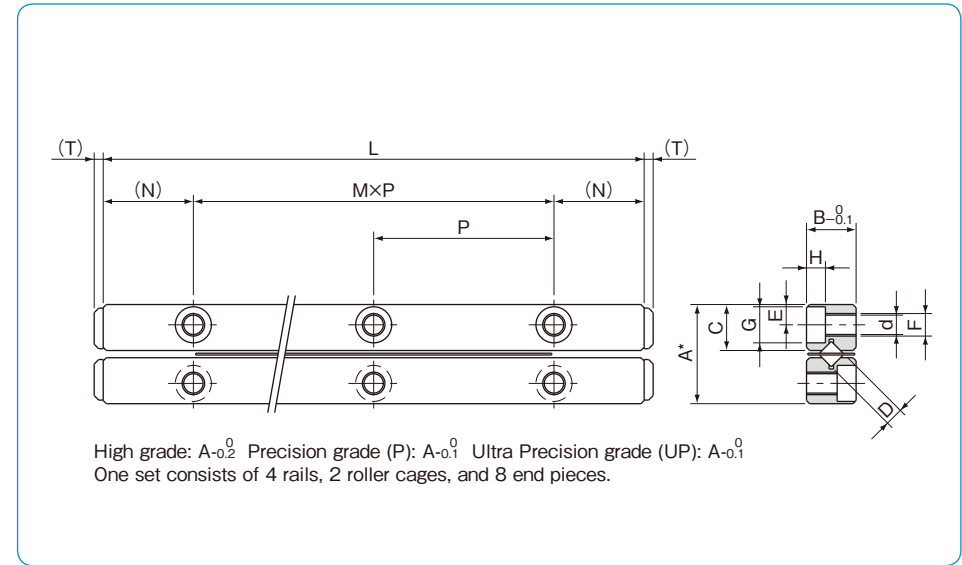

major dimensions								basic load rating		allowable load F N	mass (one set) g	size
M × P mm	N mm	E mm	F mm	d mm	G mm	H mm	T mm	dynamic C N	static Co N			
1 × 50	25	6	M6	5.2	9.5	5.2	3	20,700	23,600	7,880	628	6100
2 × 50								28,500	35,500	11,800	942	6150
3 × 50								35,700	47,300	15,700	1,260	6200
4 × 50								42,500	59,200	19,700	1,570	6250
5 × 50								49,000	71,000	23,600	1,880	6300
6 × 50								55,300	82,800	27,600	2,200	6350
7 × 50								61,400	94,700	31,500	2,510	6400
8 × 50								67,300	106,000	35,400	2,830	6450
9 × 50								73,100	118,000	39,400	3,140	6500
11 × 50								84,200	142,000	47,300	3,770	6600
1 × 100	50	9	M8	6.8	10.5	6.2	4	60,900	70,700	23,500	2,720	9200
2 × 100								79,300	98,900	32,900	4,030	9300
3 × 100								104,000	141,000	47,000	5,380	9400
4 × 100								120,000	169,000	56,400	6,700	9500
5 × 100								143,000	212,000	70,500	8,050	9600
6 × 100								158,000	240,000	79,900	9,230	9700
7 × 100								180,000	282,000	94,000	10,500	9800
8 × 100								193,000	311,000	103,000	11,900	9900
9 × 100								214,000	353,000	117,000	13,000	91000

1N=0.102kgf

※Maximum Rail Length (standard type only)

part number	Max. length
SV6	700mm

※Please contact NB for details.

SV TYPE

-SV12-

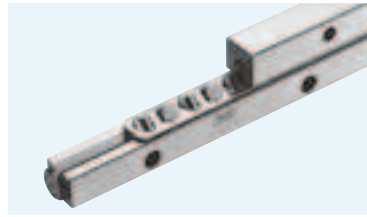

part number structure

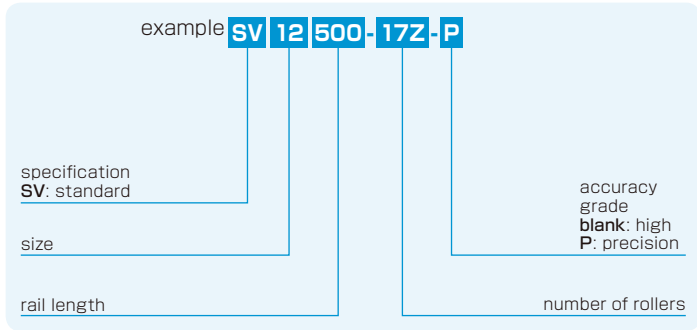

part number		stroke	roller diameter	number of rollers	L	A	B	C
standard	anti-corrosion	ST mm	D mm	Z	mm	mm	mm	mm
SV 12300-10Z	—	200	12	10	300	58	28	27
12400-14Z	—	240		14	400			
12500-17Z	—	320		17	500			
12600-21Z	—	360		21	600			
12700-24Z	—	440		24	700			
12800-28Z	—	480		28	800			
12900-31Z	—	560		31	900			
121000-34Z	—	640		34	1,000			
121100-38Z	—	680		38	1,100			
121200-42Z	—	720		42	1,200			

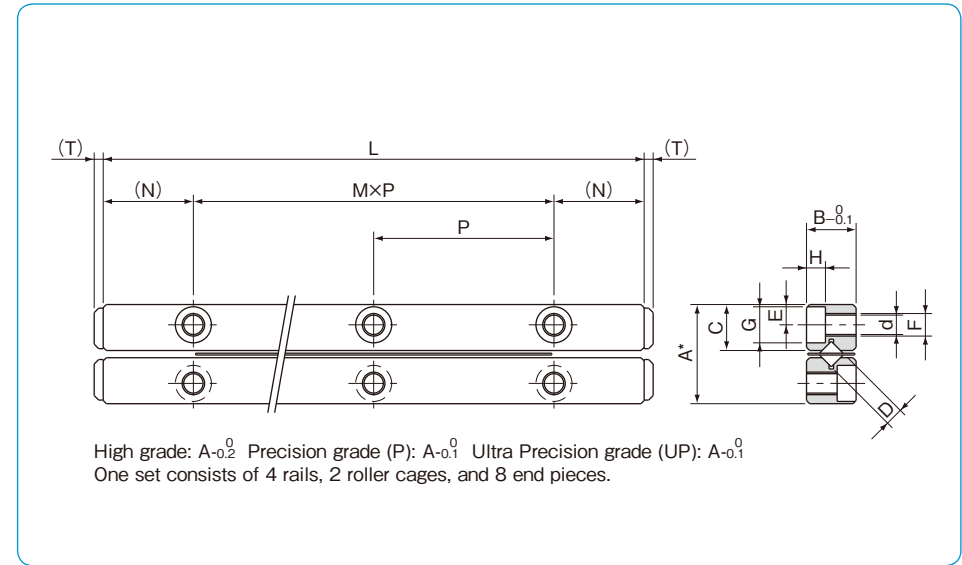

major dimensions								basic load rating				allowable load		mass	
M × P	N	E	F	d	G	H	T	dynamic C	static Co	load F	load F	mass (one set)	size		
mm	mm	mm	mm	mm	mm	mm	mm	N	N	N	N	g			
2 × 100	50	12	M10	8.5	13.5	8.2	4	124,000	145,000	48,300	6,880	12300			
3 × 100								162,000	203,000	67,600	9,090	12400			
4 × 100								180,000	232,000	77,200	11,400	12500			
5 × 100								214,000	290,000	96,600	13,700	12600			
6 × 100								247,000	348,000	115,000	15,800	12700			
7 × 100								279,000	406,000	135,000	18,200	12800			
8 × 100								294,000	435,000	144,000	20,500	12900			
9 × 100								324,000	493,000	164,000	22,800	121000			
10 × 100								354,000	551,000	183,000	25,000	121100			
11 × 100								382,000	609,000	202,000	27,300	121200			

1N=0.102kgf

SVW TYPE

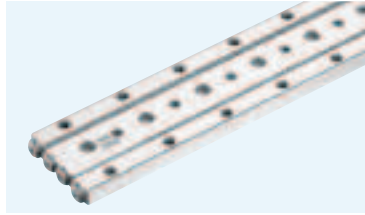

part number structure

example **SVWS 4 200-RAS 19Z-UP**

specification
SVW: standard
SVWS: anti-corrosion

size

rail length

accuracy grade
blank: high
P: precision
UP: ultra precision

number of rollers

cage type
blank: standard cage
RA: aluminum cage
 standard roller
RAS: aluminum cage
 stainless steel roller

*Refer to page G-5 for information on cage types.

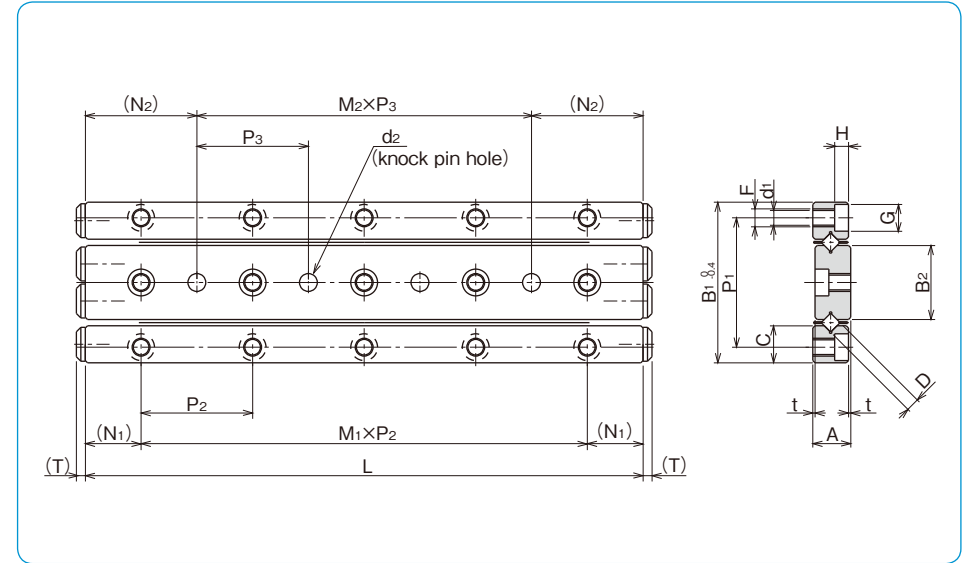

part number		stroke	roller diameter	number of rollers	L	A	t	B ₁	B ₂	C	P ₁	M ₁ × P ₂
standard	anti-corrosion	ST mm	D mm	Z	mm	mm	mm	mm	mm	mm	mm	mm
SVW 1020- 5Z	SVWS 1020- 5Z	12	1.5	5	20	4.5	0.5	17	7.6	3.8	13.4	1 × 10
1030- 7Z	1030- 7Z	20		7	30							2 × 10
1040-10Z	1040-10Z	27		10	40							3 × 10
1050-13Z	1050-13Z	32		13	50							4 × 10
1060-16Z	1060-16Z	37		16	60							5 × 10
1070-19Z	1070-19Z	42		19	70							6 × 10
1080-21Z	1080-21Z	50		21	80							7 × 10
SVW 2030- 5Z	SVWS 2030- 5Z	18		2	5							30
2045- 8Z	2045- 8Z	24	8		45	2 × 15						
2060-11Z	2060-11Z	30	11		60	3 × 15						
2075-13Z	2075-13Z	44	13		75	4 × 15						
2090-16Z	2090-16Z	50	16		90	5 × 15						
2105-18Z	2105-18Z	64	18		105	6 × 15						
2120-21Z	2120-21Z	70	21		120	7 × 15						
SVW 3050- 7Z	SVWS 3050- 7Z	28	3		7	50	8.5	0.5	36	16.6	8.3	29
3075-10Z	3075-10Z	48		10	75	2 × 25						
3100-14Z	3100-14Z	58		14	100	3 × 25						
3125-17Z	3125-17Z	78		17	125	4 × 25						
3150-21Z	3150-21Z	88		21	150	5 × 25						
3175-24Z	3175-24Z	105		24	175	6 × 25						
3200-28Z	3200-28Z	115		28	200	7 × 25						
SVW 4080- 7Z	SVWS 4080- 7Z	58		4	7	80						
4120-11Z	4120-11Z	82	11		120	2 × 40						
4160-15Z	4160-15Z	105	15		160	3 × 40						
4200-19Z	4200-19Z	130	19		200	4 × 40						
4240-23Z	4240-23Z	150	23		240	5 × 40						
4280-27Z	4280-27Z	175	27		280	6 × 40						

major dimensions									basic load rating		allowable	mass	size
N ₁	F	d ₁	G	H	M ₂ × P ₃	N ₂	d ₂	T	dynamic C	static Co	load F	(one set) g	
mm		mm	mm	mm	mm	mm	mm	mm	N	N	N		
5	M2	1.65	3	1.4	—	10	2 ^{+0.010} ₀	0.8	464	476	158	11	1020
					1 × 10				641	714	237	14	1030
					2 × 10				959	1,190	396	18	1040
					3 × 10				1,100	1,420	475	22	1050
					4 × 10				1,380	1,900	633	26	1060
					5 × 10				1,510	2,140	712	30	1070
					6 × 10				1,650	2,380	792	34	1080
					7 × 10				1,800	2,630	872	38	1090
7.5	M3	2.55	4.4	2	—	15	3 ^{+0.010} ₀	2	1,090	1,170	390	28	2030
					1 × 15				1,900	2,340	780	42	2045
					2 × 15				2,270	2,930	976	55	2060
					3 × 15				2,620	3,510	1,170	69	2075
					4 × 15				3,280	4,680	1,560	83	2090
					5 × 15				3,590	5,270	1,750	96	2105
					6 × 15				3,900	5,860	1,950	110	2120
					7 × 15				4,210	6,450	2,150	124	2135
12.5	M4	3.3	6	3.1	—	25	4 ^{+0.012} ₀	2	3,490	3,890	1,290	94	3050
					1 × 25				5,230	6,490	2,160	135	3075
					2 × 25				6,810	9,080	3,020	187	3100
					3 × 25				7,560	10,300	3,450	234	3125
					4 × 25				9,000	12,900	4,320	281	3150
					5 × 25				10,300	15,500	5,180	327	3175
					6 × 25				11,700	18,100	6,040	374	3200
					7 × 25				13,100	20,700	6,900	421	3225
20	M5	4.3	8	4.2	—	40	5 ^{+0.012} ₀	2	7,110	7,920	2,640	255	4080
					1 × 40				10,600	13,200	4,400	385	4120
					2 × 40				13,800	18,400	6,160	510	4160
					3 × 40				16,800	23,700	7,920	635	4200
					4 × 40				19,700	29,000	9,680	770	4240
					5 × 40				22,400	34,300	11,400	905	4280

1N=0.102kgf

SLIDE TABLE

The NB slide table is a precision table equipped with a slide way. Its high-precision and low-friction characteristics make it well suited for use in electronics automatic-assembly machines, optical measurement devices, etc.

STRUCTURE AND ADVANTAGES

The NB slide table consists of a slide way sandwiched between an accurately machined table and a bed. Stoppers are provided inside the table.

High Accuracy

The mounting surfaces of the table and bed are precision finished to ensure high precision linear motion, resulting in a high performance slide way.

Low Friction

Its non-recirculating mechanism provides stable motion at from low to high speeds.

Compact and High Rigidity

Being designed compactly, the NB slide table holds the high load capacity and high rigidity characteristics.

No Need for Adjustment

The table is carefully assembled so that the accuracy and preload are optimized, it can be used immediately without any further adjustment.

Ease of Mounting

Standardized mounting holes are provided in the table and bed. High precision linear motion can be achieved simply by mounting.

Figure G-16 Structure of NVT type

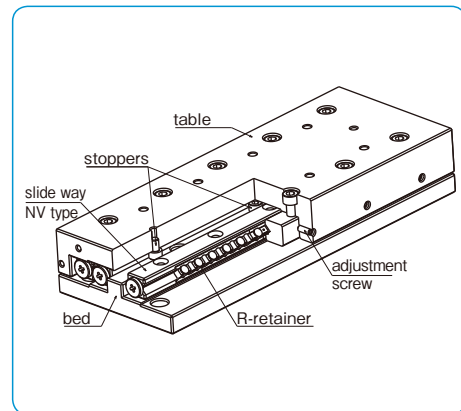
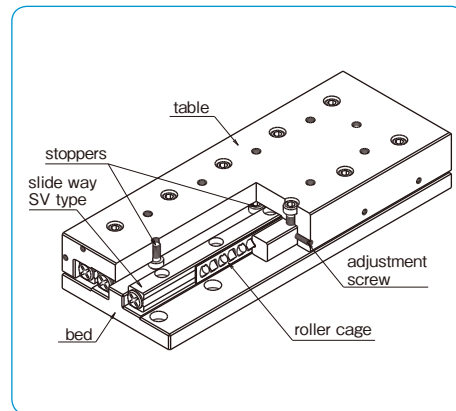
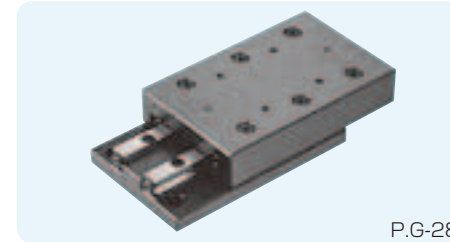

Figure G-17 Structure of SVT type



TYPES

NVT type



P.G-28

The NVT type slide table incorporates the NV type slide way. The table and bed have been precision machined to provide a high degree of accuracy and the product can be used, without any need for troublesome accuracy or preload adjustments.

SVT·SVTS type

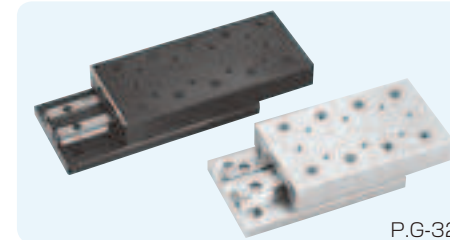

P.G-32

In the SVT type slide table, the SV type slide way is sandwiched between an accurately machined steel table and bed.

In the SVTS type, the anti-corrosion SVS type slide way is sandwiched between an accurately machined aluminum table and bed.

SYT·SYTS type

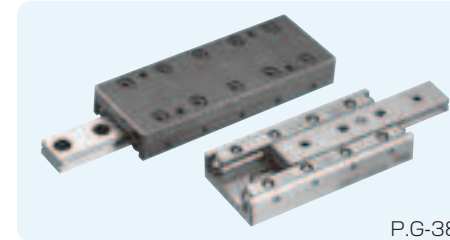

P.G-38

The SYT/SYTS type is a thin, compact slide table. Either tapped or counterbore type (D type) is available for the mounting hole.

The anti-corrosion SYTS type slide table is made of all stainless steel components, making it suitable for use in clean rooms.

ACCURACY

The motion accuracy of a slide table is measured by placing indicators at the center of the top and side surface of the table, as illustrated in Figure G-18. It is expressed in terms of the indicator deviation when the table is moved the full stroke without any load.

Figure G-18 Accuracy Measurement Method

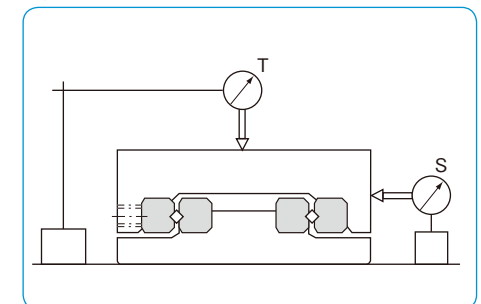

RATED LIFE

The life of an NB slide table is calculated using the following equations.

Rated Life

$$L = \left(\frac{f_T \cdot C}{f_w \cdot P} \right)^{10/3} \cdot 50$$

L: rated life(km) f_T: temperature coefficient f_w: applied load coefficient
C: basic dynamic load rating(N) P: applied load(N)
※Please refer to page Eng-5 for the coefficients.

Life Time

$$L_h = \frac{L \cdot 10^3}{2 \cdot l_s \cdot n \cdot 60}$$

L_h: life time (hr) l_s: stroke length (m)
n: number of cycles per minute (cpm)

LOAD RATING

The load rating of the slide table NVT type differs depending on the direction of the load.

Table G-6 Change of Load Rating Corresponding to Load Direction

basic dynamic load rating	normal vertical direction	1.0×C
	horizontal direction	0.85×C
	reverse vertical direction	0.7×C
basic static load rating	normal vertical direction	1.0×C ₀
	horizontal direction	0.85×C ₀
	reverse vertical direction	0.7×C ₀

※There may be a difference depending on the size. Please contact NB for details.
Consideration has been given to holes for STUDROLLERS in the raceway surface in calculation of load ratings.

Figure G-19 Direction of Load

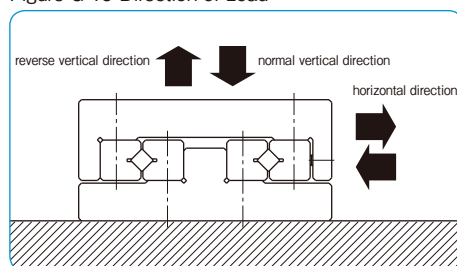

USE AND HANDLING PRECAUTIONS

Careful Handling

Dropping the slide table causes the rolling elements to make dents in the raceway surface. This will prevent smooth motion and will also affect accuracy. Be sure to handle the product with care.

Dust Prevention

Dust and foreign particles affect the accuracy and lifetime of a slide table. A slide table used in a harsh environment should be protected with a cover.

Lubrication

The slide table is prelubricated with lithium soap based grease prior to shipment for immediate use. Make sure to relubricate with a similar type of grease periodically depending on the operating conditions.

Cage Slippage

The cage can slip under high-speed motion, unbalanced-loading, and vibrating conditions. It is suggested that the motion speed of a slide table

be kept under 30 m/min under general operating conditions.

It is recommended that the table be cycled to perform maximum full stroke several times during operation. This will allow the roller cage to be returned to its normal central position.

Adjustment/Installation Screw

The NB slide table is adjusted to achieve optimum accuracy and preload. The adjustment screw and rail installation screws should be kept untouched.

Allowable Load

The allowable load is a load under which the sum of elastic deformations of the rolling element and the raceway in the contact area subject to the maximum contact stress is small enough to guarantee smooth rolling movement. When very smooth and highly accurate linear motion is required, make sure to use the product within the allowable load.

SPECIAL REQUIREMENTS

NB can machine tables to meet special requirements, including tables with a micrometer head and tables for projectors. Please contact NB for details.

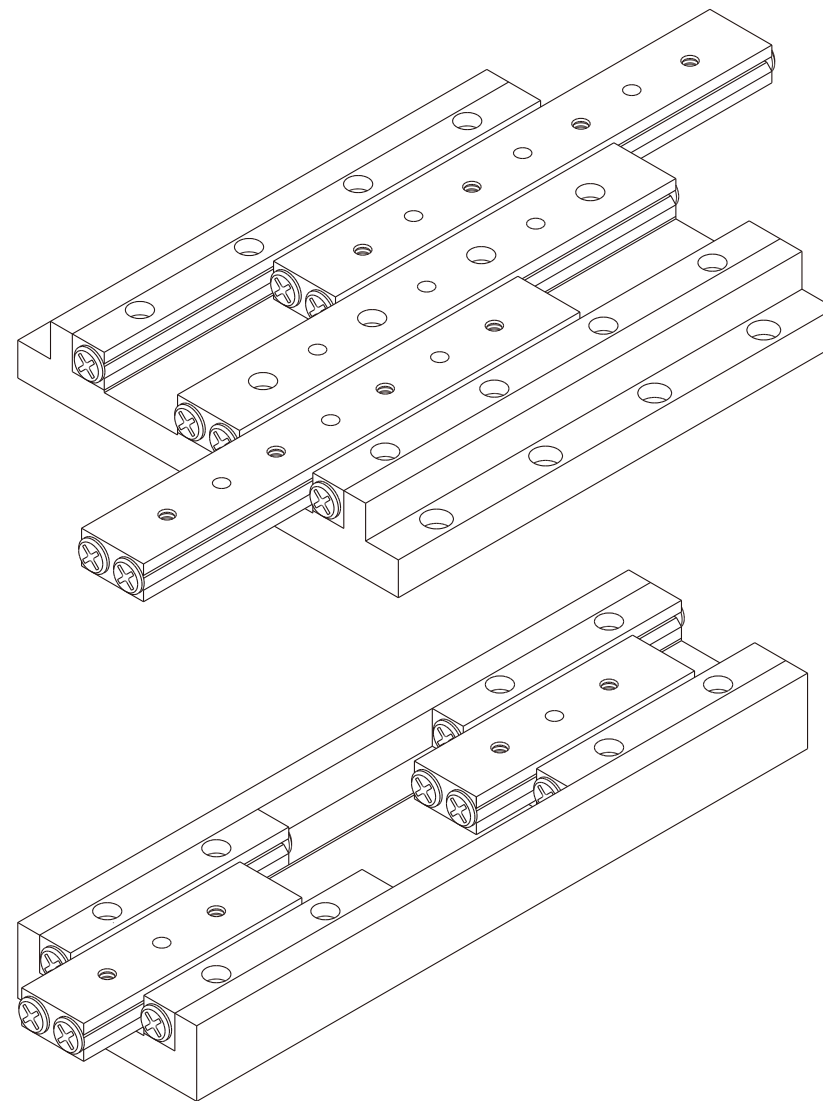

NVT TYPE

-NVT2/NVT3/NVT4-

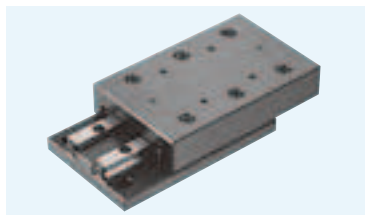

part number structure

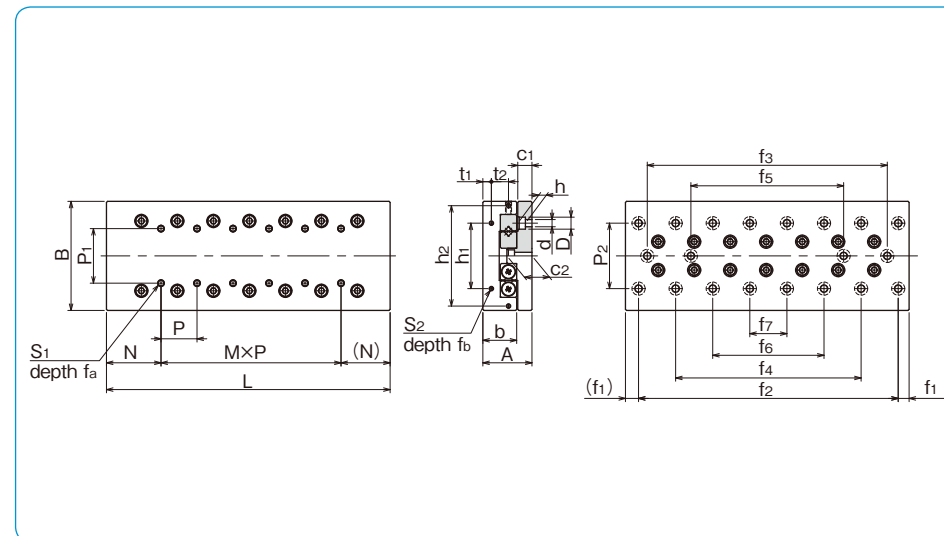
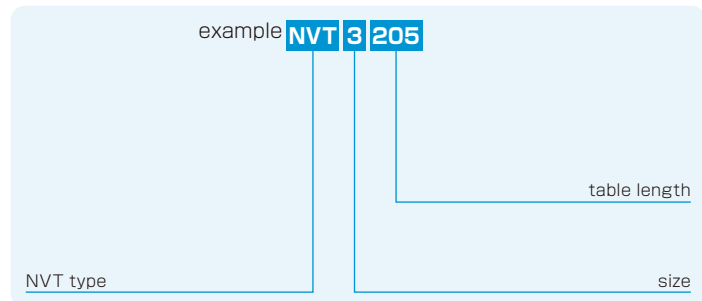

part number	stroke ST mm	major dimensions					table-top mounting hole dimensions					table-end mounting hole dimensions					d×D×h mm	
		A mm	B mm	L mm	b mm	P ₁ mm	S ₁ mm	f _a mm	N mm	M×P mm	h ₁ mm	h ₂ mm	t ₁ mm	t ₂ mm	S ₂ mm	f _b mm		P ₂ mm
NVT2035	18			35					—									
2050	30			50				1×15										
2065	40			65				2×15										
2080	50			80				3×15										
2095	60			95				4×15										
2110	70	21±0.1	40 ^{-0.2}	110	14	15	M3	6	17.5	5×15	16	—	3.4	—	M2	6	30	3.5×6.5×3.5
2125	80			125				6×15										
2140	90			140				7×15										
2155	100			155				8×15										
2170	110			170				9×15										
2185	120			185				10×15										
NVT3055	30			55				—										
3080	45			80				1×25										
3105	60			105				2×25										
3130	75	28±0.1	60±0.1	130	18.5	25	M4	8	27.5	3×25	40	—	5.5	—	M3	6	40	4.5×8×4.5
3155	90			155				4×25										
3180	105			180				5×25										
3205	130			205				6×25										
3230	155			230				7×25										
NVT4085	50			85				—										
4125	75			125				1×40										
4165	105	35±0.1	80±0.1	165	24	40	M5	10	42.5	2×40	55	—	6.5	—	M3	6	55	5.5×10×5.4
4205	130			205				3×40										
4245	155			245				4×40										
4285	185			285				5×40										

The basic static load rating is the value at the center of the stroke.

bed-surface mounting hole dimensions								accuracy ※(deviation)		basic load rating dynamic		allowable load	allowable static moment			mass	size			
C ₁ mm	C ₂ mm	f ₁ mm	f ₂ mm	f ₃ mm	f ₄ mm	f ₅ mm	f ₆ mm	f ₇ mm	T μm	S μm	C N	Co N	F N	M _P N·m	M _Y N·m	M _R N·m	g			
6.5	10.9	5	25	—	—	—	—	—	2	4	1,360	1,520	509	10.1	8.8	13.7	200	2035		
			40	—	—	—	—	—	—	2	4	2,330	3,050	1,010	18.9	18.7	21.1	287	2050	
			55	—	—	—	—	—	—	2	5	3,190	4,580	1,520	36.9	35.7	34.8	377	2065	
			70	—	40	—	—	—	—	2	5	3,990	6,110	2,030	53.2	53.8	39.8	455	2080	
			85	—	55	—	—	—	—	2	5	4,740	7,630	2,540	80.3	79.9	53.5	550	2095	
			100	—	70	—	—	—	—	3	6	5,460	9,160	3,050	104	106	58.4	640	2110	
			115	—	85	—	—	—	—	3	6	6,160	10,600	3,560	130	135	63.4	730	2125	
			130	—	100	—	70	—	—	—	3	6	6,830	12,200	4,070	171	176	77.1	810	2140
			145	—	115	—	85	—	—	—	3	6	8,130	15,200	5,090	235	244	90.9	890	2155
			160	—	130	—	100	—	—	—	3	7	8,750	16,800	5,600	275	289	95.8	980	2170
9	15	10	175	—	145	—	115	85	3	7	9,370	18,300	6,110	317	338	100	1,070	2185		
			35	—	—	—	—	—	—	2	5	6,150	8,060	2,680	13.3	34	21.2	643	3055	
			60	—	—	—	—	—	—	2	5	8,440	12,100	4,030	122	117	134	960	3080	
			85	—	—	—	—	—	—	3	6	10,500	16,100	5,370	178	181	148	1,260	3105	
			110	—	—	—	—	—	—	3	6	14,400	24,200	8,060	275	310	162	1,580	3130	
			135	85	—	—	—	—	—	3	6	16,300	28,200	9,410	492	497	275	1,860	3155	
			160	110	—	—	—	—	—	3	7	18,100	32,200	10,700	602	622	289	2,160	3180	
			185	135	85	—	—	—	—	—	3	7	19,800	36,300	12,100	719	758	303	2,460	3205
			210	160	110	—	—	—	—	—	3	7	21,500	40,300	13,400	906	941	360	2,780	3230
			10.5	18	10	65	—	—	—	—	—	2	5	12,100	15,700	5,250	150	144	250	1,710
105	—	—				—	—	—	—	3	6	20,700	31,500	10,500	311	350	312	2,520	4125	
145	—	—				—	—	—	—	3	7	24,700	39,300	13,100	631	647	532	3,320	4165	
185	105	—				—	—	—	—	3	7	32,100	55,100	18,300	1,250	1,240	847	4,130	4205	
225	145	—				—	—	—	—	3	7	39,000	70,900	23,600	1,700	1,770	909	4,930	4245	
265	185	—				—	—	—	—	3	7	42,400	78,700	26,200	2,330	2,380	1,120	5,730	4285	

※For accuracy (T, S), refer to Figure G-18 (page G-25).

1N≒0.102kgf 1N·m≒0.102kgf·m

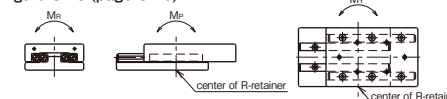

NVT TYPE

-NVT6/NVT9-

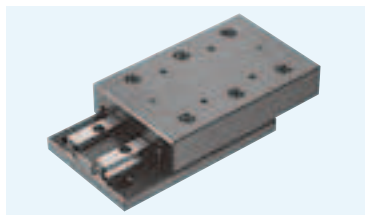

part number structure

example **NVT 6 210**

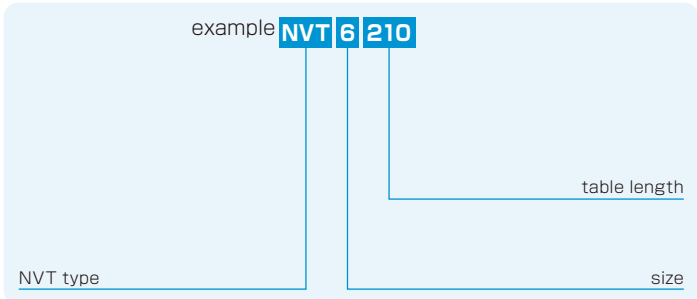

part number	stroke ST mm	major dimensions				table-top mounting hole dimensions					table-end mounting hole dimensions						d×D×h mm	
		A mm	B mm	L mm	b mm	P ₁ mm	S ₁ mm	f _a mm	N mm	M×P mm	h ₁ mm	h ₂ mm	t ₁ mm	t ₂ mm	S ₂ mm	f _b mm		P ₂ mm
NVT6110	60			110					—									
6160	95			160					1×50									
6210	130			210					2×50									
6260	165	45±0.1	100±0.1	260	31	50	M6	12	55	3×50	60	92	8	15	M4	8	60	7×11.5×7
6310	200			310						4×50								
6360	235			360						5×50								
6410	265			410						6×50								
NVT9210	130			210					—									
9310	180	60±0.1	145±0.1	310	43	85	M8	16	105	1×100	90	135	11	20	M4	8	90	9×14×9
9410	220			410						2×100								
9510	300			510						3×100								

The basic static load rating is the value at the center of the stroke.

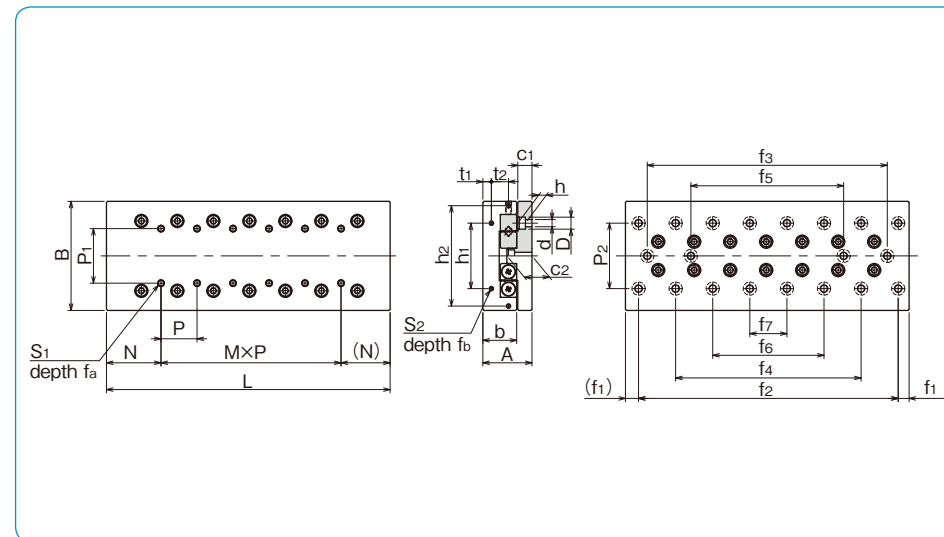

bed-surface mounting hole dimensions										accuracy ※(deviation)		basic load rating		allowable load	allowable static moment			mass	size
c ₁ mm	c ₂ mm	f ₁ mm	f ₂ mm	f ₃ mm	f ₄ mm	f ₅ mm	f ₆ mm	f ₇ mm	T μm	S μm	C N	Co N	F N	M _P N·m	M _Y N·m	M _R N·m	g		
13	23	10	90	—	—	—	—	—	3	6	29,600	37,500	12,500	216	303	343	3,300	6110	
			140	—	—	—	—	—	3	6	40,700	56,300	18,700	937	927	995	4,850	6160	
			190	90	—	—	—	—	—	3	7	60,600	93,900	31,300	1,950	1,980	1,410	6,310	6210
			240	140	—	—	—	—	—	3	7	69,800	112,000	37,500	2,670	2,770	1,640	7,790	6260
			290	190	—	—	—	—	—	3	7	78,800	131,000	43,800	4,460	4,410	2,490	9,260	6310
			340	240	140	—	—	—	—	—	4	8	87,400	150,000	50,100	5,570	5,580	2,720	10,900
16	29	55	390	290	190	—	—	—	4	8	104,000	187,000	62,600	7,440	7,660	2,950	12,460	6410	
			100	—	—	—	—	—	—	3	6	96,000	128,000	42,600	1,700	2,110	2,260	12,550	9210
			200	—	—	—	—	—	—	3	6	143,000	213,000	71,100	6,560	6,580	5,330	18,000	9310
			300	100	—	—	—	—	—	3	7	186,000	298,000	99,500	12,600	12,700	7,770	24,010	9410
			400	200	—	—	—	—	—	3	7	206,000	341,000	113,000	18,700	18,600	10,200	30,100	9510

※For accuracy (T, S), refer to Figure G-18 (page G-25).

1N≒0.102kgf 1N·m≒0.102kgf·m

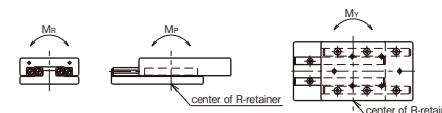

SVT TYPE

-SVT1/SVT2-

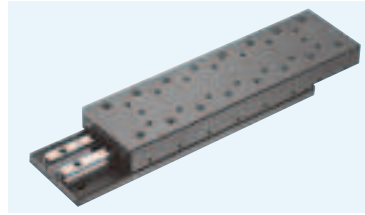

part number structure

example **SVTS 2 170**

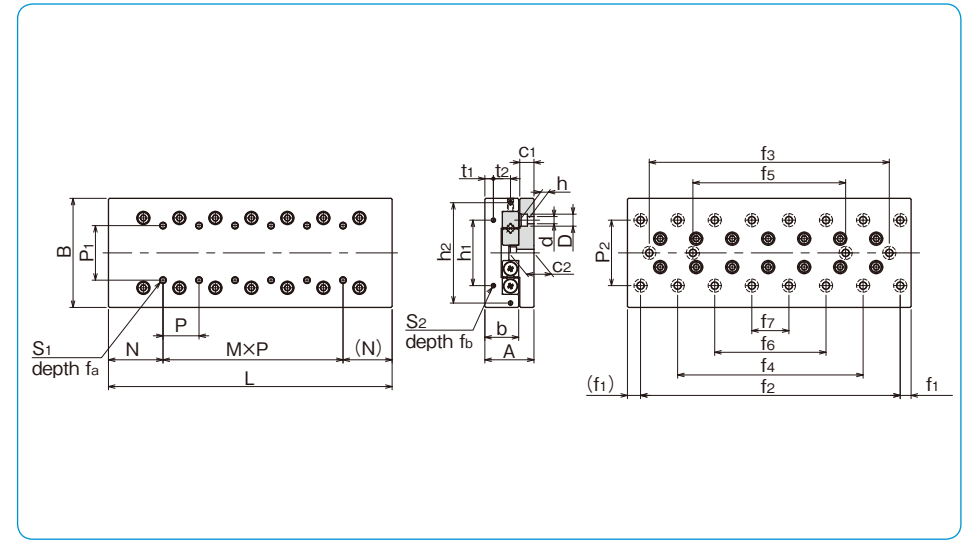
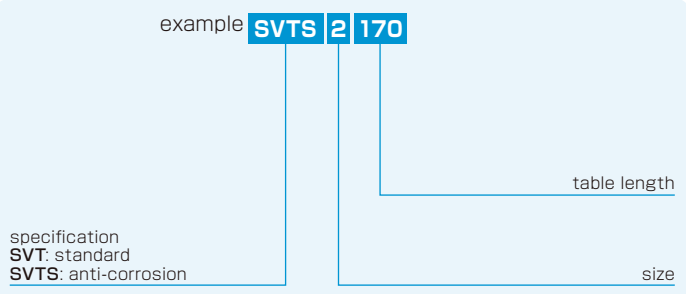

part number		stroke ST mm	major dimensions				table-top mounting hole dimensions				table-end mounting hole dimensions					
standard	anti-corrosion		A mm	B mm	L mm	b mm	P ₁ mm	S ₁ mm	f _a mm	N mm	M×P mm	h ₁ mm	h ₂ mm	t ₁ mm	t ₂ mm	S ₂ mm
SVT 1025	SVTS 1025	12	17±0.1	30 ^{-0.2}	25	10	M2	4	12.5	—	12	—	2.5	—	M2	6
1035	1035	18			35					1×10						
1045	1045	25			45					2×10						
1055	1055	32			55					3×10						
1065	1065	40			65					4×10						
1075	1075	45			75					5×10						
1085	1085	50			85					6×10						
SVT 2035	SVTS 2035	18	21±0.1	40 ^{-0.2}	35	14	15	M3	6	—	16	—	3.4	—	M2	6
2050	2050	30			50					1×15						
2065	2065	40			65					2×15						
2080	2080	50			80					3×15						
2095	2095	60			95					4×15						
2110	2110	70			110					5×15						
2125	2125	80			125					6×15						
2140	2140	90			140					7×15						
2155	2155	100			155					8×15						
2170	2170	110			170					9×15						
2185	2185	120			185					10×15						

bed-surface mounting hole dimensions												accuracy ※(deviation)		basic load rating dynamic static		allowable load		allowable static moment			mass		size
P ₂ mm	d×D×h mm	c ₁ mm	c ₂ mm	f ₁ mm	f ₂ mm	f ₃ mm	f ₄ mm	f ₅ mm	f ₆ mm	f ₇ mm	T μm	S μm	C N	Co N	F N	M _P N·m	M _V N·m	M _R N·m	SVT g	SVTS g			
22	2.5×4.5×2.5	5.5	9	3.5	18	—	—	—	—	—	2	4	464	476	158	1.79	1.47	3.22	82	36	1025		
					28	—	—	—	—	—	2	4	805	952	316	3.08	3.5	6.45	120	50	1035		
					38	—	—	—	—	—	—	2	4	959	1,190	396	6.98	6.4	8.06	158	69	1045	
					48	—	28	—	—	—	—	2	5	1,100	1,420	475	9.53	8.81	9.68	190	83	1055	
					58	—	38	—	—	—	—	2	5	1,240	1,660	554	12.4	11.6	11.2	225	98	1065	
					68	—	48	—	—	—	—	2	5	1,510	2,140	712	19.3	18.3	14.5	260	113	1075	
					78	—	58	—	—	—	—	2	5	1,650	2,380	792	23.4	22.3	16.1	295	128	1085	
					25	—	—	—	—	—	—	—	2	4	1,090	1,170	390	7.04	5.78	10.5	195	90	2035
30	3.5×6.5×3.5	6.5	10.9	5	40	—	—	—	—	—	2	4	1,510	1,750	585	12.1	10.7	15.8	280	133	2050		
					55	—	—	—	—	—	2	5	1,900	2,340	780	19.1	17.1	21.1	370	175	2065		
					70	—	40	—	—	—	—	2	5	2,620	3,510	1,170	27.4	29.6	31.6	450	220	2080	
					85	—	55	—	—	—	—	2	5	2,950	4,100	1,360	37.4	39.9	36.9	540	250	2095	
					100	—	70	—	—	—	—	3	6	3,280	4,680	1,560	61.7	58.1	42.2	630	285	2110	
					115	—	85	—	—	—	—	3	6	3,590	5,270	1,750	76.1	72.1	47.5	720	330	2125	
					130	—	100	—	70	—	—	3	6	4,210	6,440	2,140	92	95.9	58.1	800	360	2140	
					145	—	115	—	85	—	—	3	6	4,500	7,030	2,340	109	113	63.3	880	400	2155	
					160	—	130	—	100	—	—	3	7	4,790	7,610	2,530	148	143	68.6	970	440	2170	
					175	—	145	—	115	85	—	3	7	5,080	8,200	2,730	170	164	73.9	1,060	480	2185	

※For accuracy (T, S), refer to Figure G-18 (page G-25).

1N≒0.102kgf 1N·m≒0.102kgf·m

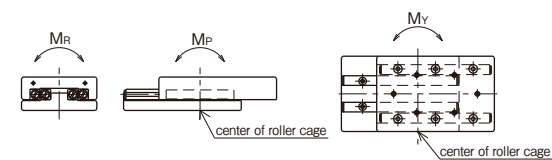

SVT TYPE

-SVT3/SVT4-

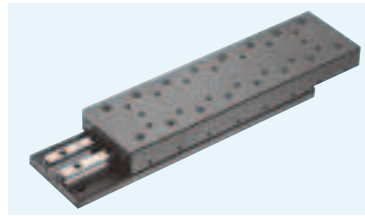

part number structure

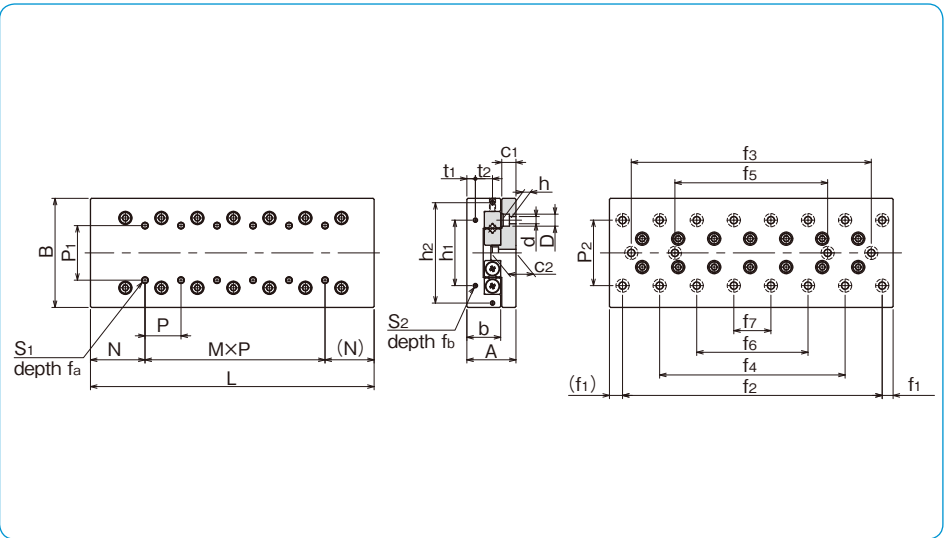
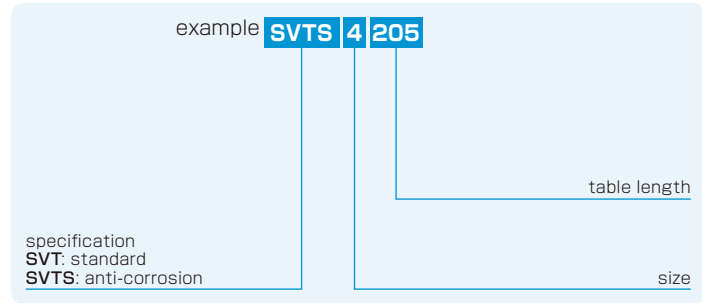

part number		stroke ST mm	major dimensions				table-top mounting hole dimensions				table-end mounting hole dimensions						
standard	anti-corrosion		A mm	B mm	L mm	b mm	P ₁ mm	S ₁ mm	f _a mm	N mm	M×P mm	h ₁ mm	h ₂ mm	t ₁ mm	t ₂ mm	S ₂ mm	f _b mm
SVT 3055	SVTS 3055	30	28±0.1	60±0.1	55	18.5	25	M4	8	27.5	40	-	5.5	-	M3	6	-
3080	3080	45			1×25												
3105	3105	60			2×25												
3130	3130	75			3×25												
3155	3155	90			4×25												
3180	3180	105			5×25												
3205	3205	130			6×25												
3230	3230	155			7×25												
3255	3255	180			8×25												
3280	3280	205			9×25												
3305	3305	230	10×25														
SVT 4085	SVTS 4085	50	35±0.1	80±0.1	85	24	40	M5	10	42.5	55	-	6.5	-	M3	6	-
4125	4125	75			1×40												
4165	4165	105			2×40												
4205	4205	130			3×40												
4245	4245	155			4×40												
4285	4285	185			5×40												
4325	4325	210			6×40												
4365	4365	235			7×40												
4405	4405	265			8×40												

P ₂ mm	bed-surface mounting hole dimensions							accuracy ※(deviation)		basic load rating		allowable load		allowable static moment			mass		size		
	d×D×h mm	c ₁ mm	c ₂ mm	f ₁ mm	f ₂ mm	f ₃ mm	f ₄ mm	f ₅ mm	f ₆ mm	f ₇ mm	T μm	S μm	C N	Co N	F N	M _P N·m	M _Y N·m	M _R N·m		SVT g	SVTS g
40	4.5×8×4.5	9	15	10	35	-	-	-	-	-	2	5	3,490	3,890	1,290	19.4	222	54.5	640	300	3055
					60	-	-	-	-	-	2	5	5,230	6,490	2,160	53.0	58.0	90.9	955	440	3080
					85	-	-	-	-	-	3	6	6,030	7,780	2,590	103	95.7	109	1,250	580	3105
					110	-	-	-	-	-	3	6	7,560	10,300	3,450	170	160	145	1,570	715	3130
					135	85	-	-	-	-	3	6	9,000	12,900	4,320	210	220	181	1,850	850	3155
					160	110	-	-	-	-	3	7	10,300	15,500	5,180	302	314	218	2,150	990	3180
					185	135	85	-	-	-	3	7	11,000	16,800	5,610	355	367	236	2,450	1,130	3205
					210	160	110	-	-	-	3	7	11,700	18,100	6,040	472	455	254	2,740	1,270	3230
					235	185	135	-	-	-	3	7	12,900	20,700	6,910	537	552	290	3,040	1,410	3255
					260	210	160	110	-	-	3	7	13,600	22,000	7,340	606	622	309	3,360	1,540	3280
55	5.5×10×5.4	10.5	18	10	285	235	185	135	-	-	3	7	14,200	23,300	7,770	757	735	372	3,660	1,680	3305
					65	-	-	-	-	-	2	5	7,110	7,920	2,640	96.0	84.9	159	1,700	780	4085
					105	-	-	-	-	-	3	6	10,600	13,200	4,400	217	199	265	2,500	1,140	4125
					145	-	-	-	-	-	3	7	13,800	18,400	6,160	296	316	371	3,300	1,510	4165
					185	105	-	-	-	-	3	7	16,800	23,700	7,920	488	513	477	4,100	1,870	4205
					225	145	-	-	-	-	3	7	19,700	29,000	9,680	729	759	584	4,900	2,240	4245
					265	185	-	-	-	-	3	7	22,400	34,300	11,400	1,010	1,050	690	5,700	2,600	4285
					305	225	145	-	-	-	4	8	25,100	39,600	13,200	1,350	1,390	796	6,500	3,000	4325
					345	265	185	-	-	-	4	8	27,600	44,800	14,900	1,730	1,780	902	7,300	3,300	4365
					385	305	225	-	-	-	4	8	28,900	47,500	15,800	2,160	2,100	955	8,100	3,700	4405

※For accuracy (T, S), refer to Figure G-18 (page G-25). 1N≒0.102kgf 1N·m≒0.102kgf·m

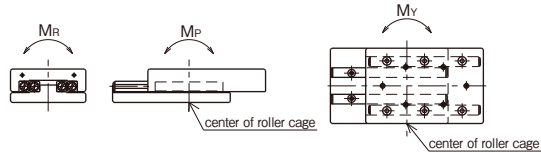

SVT TYPE

-SVT6/SVT9-

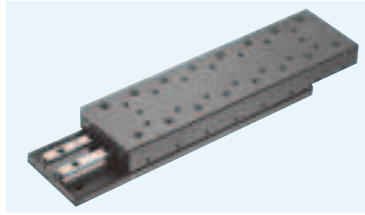

part number structure

example **SVTS 6 210**

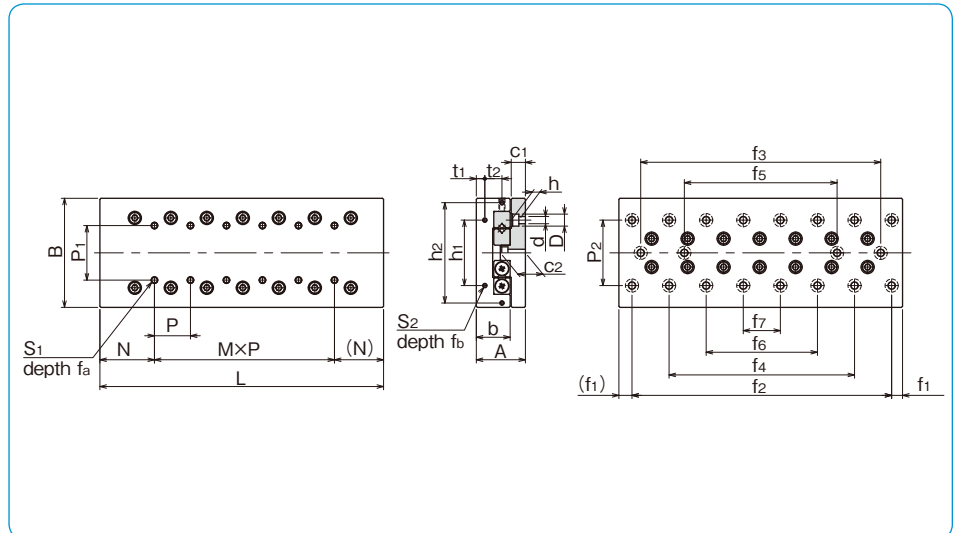
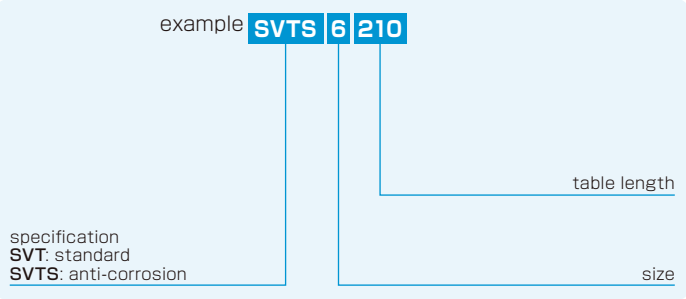

part number		stroke ST mm	major dimensions				table-top mounting hole dimensions				table-end mounting hole dimensions						
standard	anti-corrosion		A mm	B mm	L mm	b mm	P ₁ mm	S ₁ mm	f _a mm	N mm	M×P mm	h ₁ mm	h ₂ mm	t ₁ mm	t ₂ mm	S ₂ mm	f _b mm
SVT 6110	SVTS 6110	60			110					—							
6160	6160	95			160					1×50							
6210	6210	130			210					2×50							
6260	6260	165			260					3×50							
6310	6310	200	45±0.1	100±0.1	310	31	50	M6	12	55	4×50	60	92	8	15	M4	8
6360	6360	235			360						5×50						
6410	6410	265			410						6×50						
6460	6460	300			460						7×50						
6510	6510	335			510						8×50						
SVT 9210	—	130			210					—							
9310	—	180			310					1×100							
9410	—	350			410					2×100							
9510	—	450			510					3×100							
9610	—	550	60±0.1	145±0.1	610	43	85	M8	16	105	4×100	90	135	11	20	M4	8
9710	—	650			710						5×100						
9810	—	750			810						6×100						
9910	—	850			910						7×100						
91010	—	950			1,010						8×100						

bed-surface mounting hole dimensions											accuracy ※(deviation)		basic load rating dynamic static		allowable load		allowable static moment			mass		size			
P ₂ mm	d×D×h mm	c ₁ mm	c ₂ mm	f ₁ mm	f ₂ mm	f ₃ mm	f ₄ mm	f ₅ mm	f ₆ mm	f ₇ mm	T μm	S μm	C N	Co N	F N	M _P N·m	M _V N·m	M _R N·m	SVT g	SVTS g					
60	7×11.5×7	13	23	10	90	—	—	—	—	—	3	6	16,500	17,700	5,910	260	230	400	3,280	1,705	6110				
					140	—	—	—	—	—	—	—	—	3	6	24,700	29,600	9,860	588	539	666	4,820	2,480	6160	
					190	90	—	—	—	—	—	—	—	—	3	7	32,200	41,400	13,800	1,040	978	933	6,270	3,255	6210
					240	140	—	—	—	—	—	—	—	—	3	7	39,200	53,200	17,700	1,630	1,540	1,200	7,740	4,030	6260
					290	190	—	—	—	—	—	—	—	—	3	7	45,800	65,100	21,600	2,340	2,240	1,460	9,200	4,805	6310
					340	240	140	—	—	—	—	—	—	—	4	8	52,200	76,900	25,600	2,750	2,850	1,730	10,740	5,580	6360
					390	290	190	—	—	—	—	—	—	—	4	8	58,400	88,800	29,500	3,660	3,770	2,000	12,190	6,355	6410
					440	340	240	—	—	—	—	—	—	—	4	8	64,400	100,000	33,500	4,700	4,830	2,260	13,800	7,130	6460
					490	390	290	190	—	—	—	—	—	—	4	8	70,200	112,000	37,400	5,870	6,010	2,530	15,300	7,905	6510
					100	—	—	—	—	—	—	—	—	—	3	7	51,100	56,500	18,800	1,610	1,440	2,030	12,520	—	9210
					200	—	—	—	—	—	—	—	—	—	3	7	79,300	98,900	32,900	3,150	3,360	3,560	17,950	—	9310
					300	100	—	—	—	—	—	—	—	—	4	8	79,300	98,900	32,900	4,110	3,840	3,560	23,950	—	9410
400	200	—	—	—	—	—	—	—	—	4	8	96,600	127,000	42,300	6,420	6,080	4,580	30,090	—	9510					
500	300	100	—	—	—	—	—	—	—	4	9	112,000	155,000	51,700	7,760	8,090	5,600	35,990	—	9610					
600	400	200	—	—	—	—	—	—	—	4	9	128,000	183,000	61,100	10,800	11,200	6,620	41,890	—	9710					
700	500	300	100	—	—	—	—	—	—	5	10	136,000	197,000	65,800	14,400	13,900	7,130	47,790	—	9810					
800	600	400	200	—	—	—	—	—	—	5	10	151,000	226,000	75,200	18,500	17,900	8,140	53,690	—	9910					
900	700	500	300	100	—	—	—	—	—	5	10	165,000	254,000	84,600	23,100	22,400	9,160	59,590	—	91010					

※For accuracy (T, S), refer to Figure G-18 (page G-25).

1N≒0.102kgf 1N·m≒0.102kgf·m

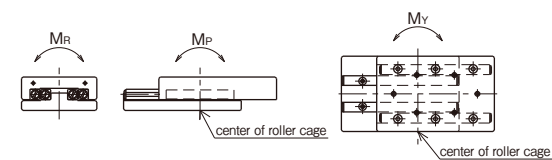

SYT TYPE

-SYT1/SYT2-

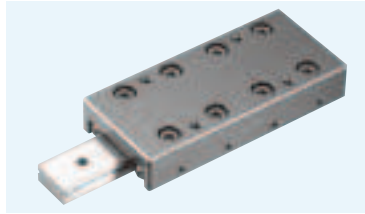

part number structure

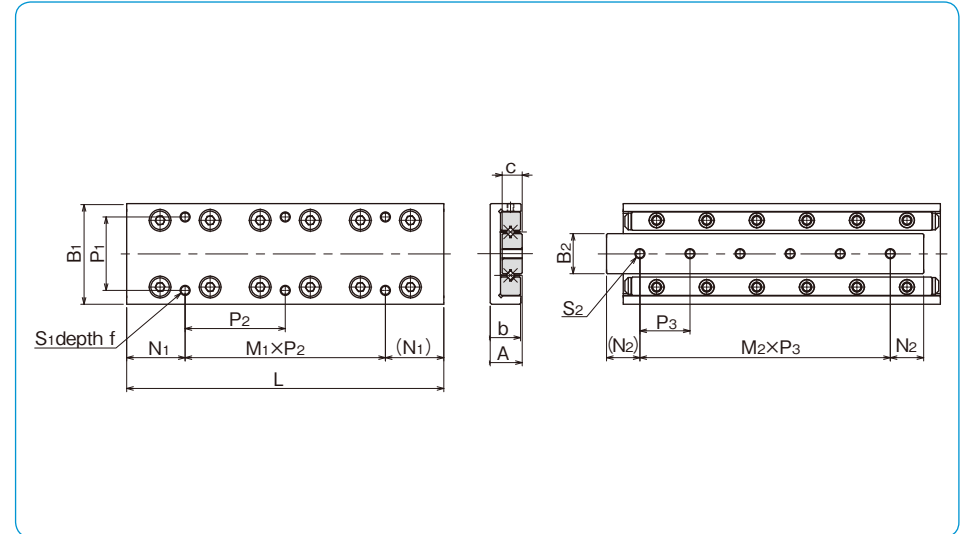
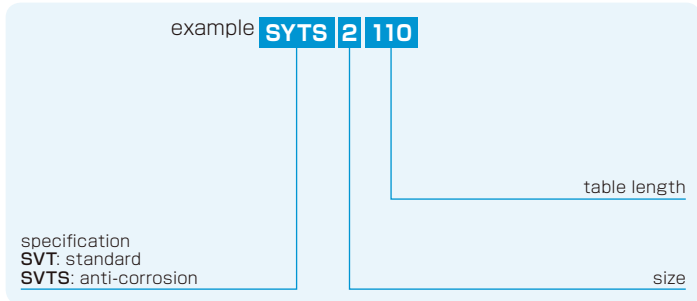

part number		stroke ST mm	major dimensions						table-top mounting hole dimensions		
standard	anti-corrosion		A mm	B ₁ mm	L mm	b mm	B ₂ mm	c mm	P ₁ mm	S ₁	f mm
SYT 1025	SYTS 1025	12	8±0.1	20±0.1	25	7.5	6.6	4	14	M2.6	3
1035	1035	18			35						
1045	1045	25			45						
1055	1055	32			55						
1065	1065	40			65						
1075	1075	45			75						
1085	1085	50			85						
SYT 2035	SYTS 2035	18	12±0.1	30±0.1	35	11.5	12	6	22	M3	5
2050	2050	30			50						
2065	2065	40			65						
2080	2080	50			80						
2095	2095	60			95						
2110	2110	70			110						
2125	2125	80			125						

N ₁ mm	M ₁ × P ₂ mm	bed-surface mounting hole dimensions		accuracy ※(deviation)		basic load rating		allowable load F N	allowable static moment			mass g	size	
		S ₂	N ₂ mm	M ₂ × P ₃ mm	T μm	S μm	C N		Co N	M _P N·m	M _V N·m			M _R N·m
3.5	1 × 18	M2.6	5	2 × 7.5	2	4	464	476	158	1.79	1.47	1.79	22	1025
3.5	1 × 28		7.5	2 × 10	2	4	805	952	316	3.08	3.50	3.58	33	1035
12.5	1 × 20		7.5	3 × 10	2	5	959	1,190	396	6.98	6.40	4.48	42	1045
12.5	1 × 30		7.5	4 × 10	2	5	1,100	1,420	475	9.53	8.81	5.37	52	1055
12.5	2 × 20		7.5	5 × 10	2	5	1,240	1,660	554	12.4	11.6	6.27	63	1065
22.5	1 × 30		7.5	6 × 10	2	5	1,510	2,140	712	19.3	18.3	8.06	72	1075
12.5	2 × 30		7.5	7 × 10	2	5	1,650	2,380	792	23.4	22.3	8.96	83	1085
3.5	1 × 28	M3	7.5	1 × 20	2	4	1,090	1,170	390	7.04	5.78	7.63	79	2035
3.5	1 × 43		10	2 × 15	2	4	1,510	1,750	585	12.1	10.7	11.4	113	2050
17.5	1 × 30		10	3 × 15	2	5	1,900	2,340	780	19.1	17.1	15.2	150	2065
17.5	1 × 45		10	4 × 15	2	5	2,620	3,510	1,170	27.4	29.6	22.8	185	2080
17.5	2 × 30		10	5 × 15	2	5	2,950	4,100	1,360	37.4	39.9	26.7	215	2095
32.5	1 × 45		10	6 × 15	2	5	3,280	4,680	1,560	61.7	58.1	30.5	255	2110
17.5	2 × 45		10	7 × 15	2	5	3,590	5,270	1,750	76.1	72.1	34.3	295	2125

※For accuracy (T, S), refer to Figure G-18 (page G-25).

1N≒0.102kgf 1N · m≒0.102kgf · m

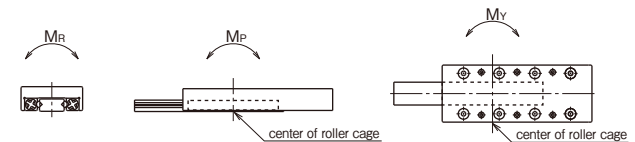

SYT TYPE

-SYT3-

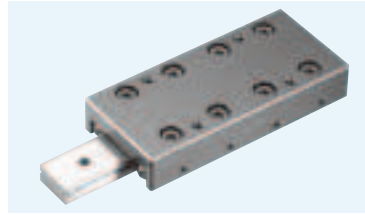

part number structure

example **SYTS 3 155**

specification
SYT: standard
SYTS: anti-corrosion

table length

size

part number		stroke ST mm	major dimensions						table-top mounting hole dimensions		
standard	anti-corrosion		A mm	B ₁ mm	L mm	b mm	B ₂ mm	c mm	P ₁ mm	S ₁	f mm
SYT 3055	SYTS 3055	30	16±0.1	40±0.1	55	15.5	16	8	30	M4	7
3080	3080	45			80						
3105	3105	60			105						
3130	3130	75			130						
3155	3155	90			155						
3180	3180	105			180						
3205	3205	130			205						

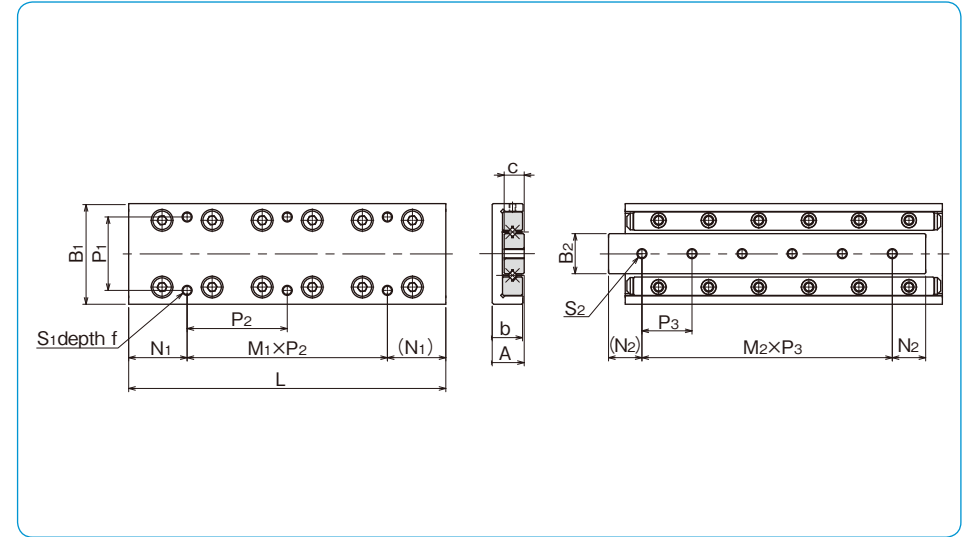

N ₁ mm	M ₁ ×P ₂ mm	bed-surface mounting hole dimensions			accuracy ※(deviation)		basic load rating		allowable load F N	allowable static moment			mass g	size
		S ₂	N ₂ mm	M ₂ ×P ₃ mm	T μm	S μm	dynamic C N	static Co N		M _P N·m	M _V N·m	M _R N·m		
7.5	1×40	M4	10	1×35	2	5	3,490	3,890	1,290	19.4	22.2	33.8	225	3055
7.5	1×65		15	2×25	2	5	5,230	6,490	2,160	53.0	58.0	56.4	340	3080
27.5	1×50		15	3×25	3	5	6,030	7,790	2,590	103	95.7	67.7	440	3105
27.5	1×75		15	4×25	3	5	7,560	10,300	3,450	170	160	90.3	560	3130
27.5	2×50		15	5×25	3	5	9,000	12,900	4,320	210	220	112	655	3155
52.5	1×75		15	6×25	3	5	10,300	15,500	5,180	302	314	135	770	3180
27.5	2×75		15	7×25	3	5	11,000	16,800	5,610	355	367	146	880	3205

※For accuracy (T, S), refer to Figure G-18 (page G-25).

1N≐0.102kgf 1N·m≐0.102kgf·m

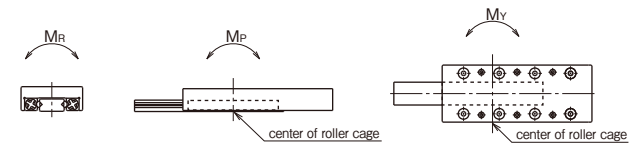

SYT-D TYPE

-SYT1/SYT2-

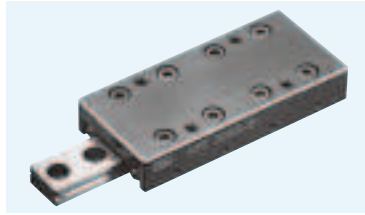

part number structure

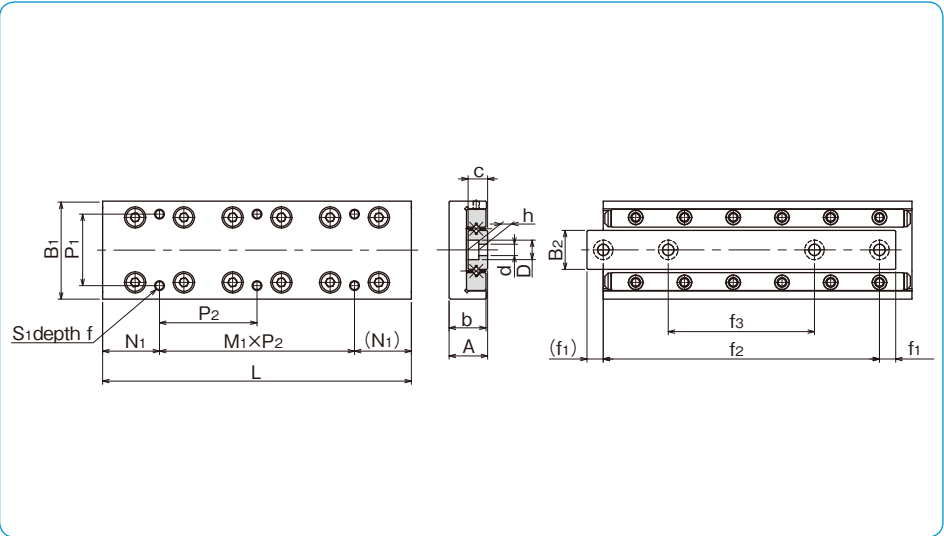
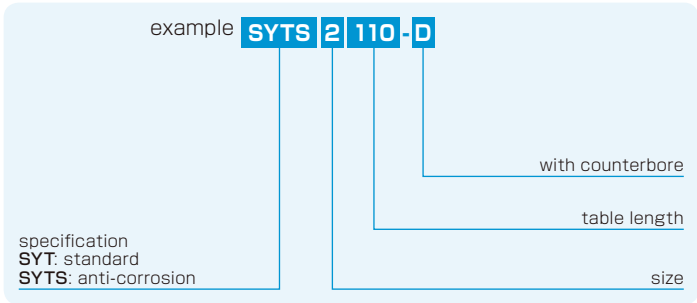

part number		stroke ST mm	major dimensions							table-top mounting hole dimensions			
standard	anti-corrosion		A mm	B1 mm	L mm	b mm	B2 mm	c mm	P1 mm	S1	f mm	N1 mm	
SYT 1025-D	SYTS1025-D	12	8±0.1	20±0.1	25	7.5	6.6	4	14	M2.6	3	3.5	
1035-D	1035-D	18			35							3.5	
1045-D	1045-D	25			45							12.5	
1055-D	1055-D	32			55							12.5	
1065-D	1065-D	40			65							12.5	
1075-D	1075-D	45			75							22.5	
1085-D	1085-D	50			85							12.5	
SYT2035-D	SYTS2035-D	18			12±0.1							30±0.1	35
2050-D	2050-D	30	50	3.5									
2065-D	2065-D	40	65	17.5									
2080-D	2080-D	50	80	17.5									
2095-D	2095-D	60	95	17.5									
2110-D	2110-D	70	110	32.5									
2125-D	2125-D	80	125	17.5									

M1xP2 mm	bed-surface mounting hole dimensions			accuracy ※(deviation)		basic load rating		allowable load F N	allowable static moment			mass g	size	
	dxDxh mm	f1 mm	f2 mm	f3 mm	T μm	S μm	C N		Co N	Mp N·m	Mv N·m			Mr N·m
1x18	2.5x4.1x2.2	3.5	18	—	2	4	464	476	158	1.79	1.47	1.79	22	1025
1x28		5	25	—	2	4	805	952	316	3.08	3.50	3.58	33	1035
1x20		3.5	38	25	2	5	959	1,190	396	6.98	6.40	4.48	42	1045
1x30		3.5	48	29	2	5	1,100	1,420	475	9.53	8.81	5.37	52	1055
2x20		5	55	31	2	5	1,240	1,660	554	12.4	11.6	6.27	63	1065
1x30		5	65	35	2	5	1,510	2,140	712	19.3	18.3	8.06	72	1075
2x30		5	75	40	2	5	1,650	2,380	792	23.4	22.3	8.96	83	1085
1x28		3.5x6x3.3	5	25	—	2	4	1,090	1,170	390	7.04	5.78	7.63	79
1x43	7.5		35	—	2	4	1,510	1,750	585	12.1	10.7	11.4	113	2050
1x30	5		55	33	2	5	1,900	2,340	780	19.1	17.1	15.2	150	2065
1x45	5		70	40	2	5	2,620	3,510	1,170	27.4	29.6	22.8	185	2080
2x30	5		85	45	2	5	2,950	4,100	1,360	37.4	39.9	26.7	215	2095
1x45	7.5		95	50	2	5	3,280	4,680	1,560	61.7	58.1	30.5	255	2110
2x45	7.5		110	55	2	5	3,590	5,270	1,750	76.1	72.1	34.3	295	2125

※For accuracy (T, S), refer to Figure G-18 (page G-25). 1N≐0.102kgf 1N · m≐0.102kgf · m

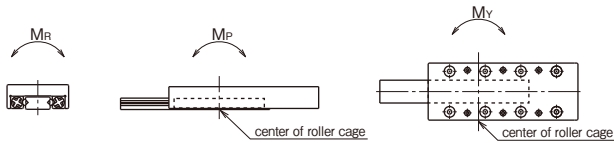

SYT-D TYPE

-SYT3-

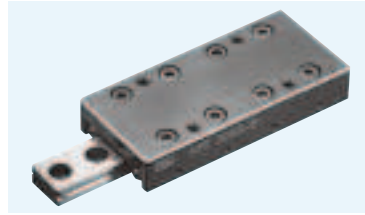

part number structure

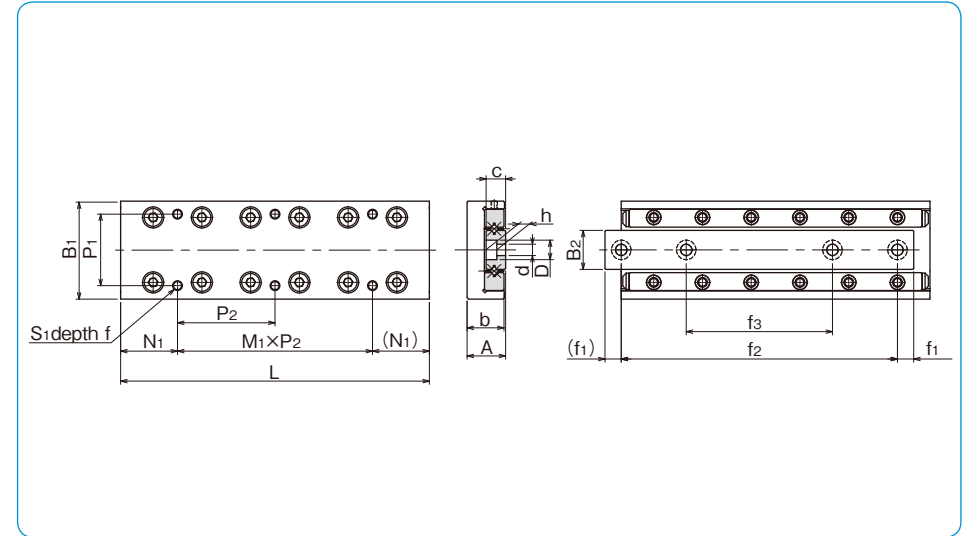
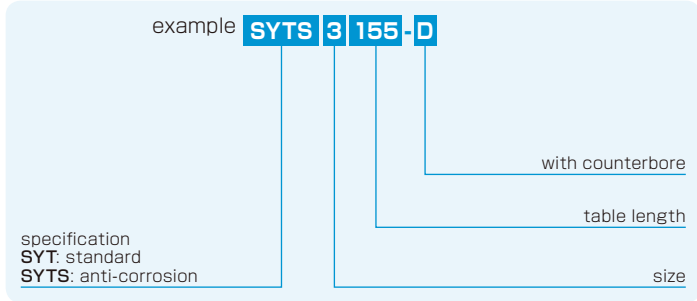

part number		stroke ST mm	major dimensions						table-top mounting hole dimensions			
standard	anti-corrosion		A mm	B ₁ mm	L mm	b mm	B ₂ mm	c mm	P ₁ mm	S ₁	f mm	N ₁ mm
SYT3055-D	SYTS3055-D	30	16±0.1	40±0.1	55	15.5	16	8	30	M4	7	7.5
3080-D	3080-D	45			80							7.5
3105-D	3105-D	60			105							27.5
3130-D	3130-D	75			130							27.5
3155-D	3155-D	90			155							27.5
3180-D	3180-D	105			180							52.5
3205-D	3205-D	130			205							27.5

M ₁ ×P ₂ mm	bed-surface mounting hole dimensions			accuracy ※(deviation)		basic load rating		allowable load F N	allowable static moment			mass g	size	
	d×D×h mm	f ₁ mm	f ₂ mm	f ₃ mm	T μm	S μm	C N		Co N	M _P N·m	M _V N·m			M _R N·m
1×40	4.5×7.5×4.3	7.5	40	—	2	5	3,490	3,890	1,290	19.4	22.2	33.8	225	3055
1×65		6	68	43	2	5	5,230	6,490	2,160	53.0	58.0	56.4	340	3080
1×50		7.5	90	55	3	5	6,030	7,780	2,590	103	95.7	67.7	440	3105
1×75		7.5	115	65	3	5	7,560	10,300	3,450	170	160	90.3	560	3130
2×50		7.5	140	95	3	5	9,000	12,900	4,320	210	220	112	655	3155
1×75		7.5	165	85	3	5	10,300	15,500	5,180	302	314	135	770	3180
2×75		7.5	190	90	3	5	11,000	16,800	5,610	355	367	146	880	3205

※For accuracy (T, S), refer to Figure G-18 (page G-25).

1N≐0.102kgf 1N·m≐0.102kgf·m

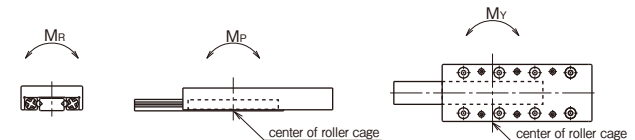

MINIATURE SLIDE

The NB miniature slide table SYBS type is a limited stroke table with the most compact envelope dimensions, featuring two ball raceway grooves. The SYBS type utilizes balls as the rolling elements. The ultra compact design contributes greatly to the creation of smaller and lighter industrial machinery and equipment of all types.

STRUCTURE AND ADVANTAGES

The NB miniature slide table incorporates a unique integrated ball cage between the table and bed. All components have been produced with high precision machining.

Ultra Compact Design

The table height of the SYBS type is 3.2~4.5mm and the width is 6~12mm. This compact size when compared with conventional slide tables helps to realize the miniaturization of machinery and equipment.

Low Friction · Low Noise

Since the rolling ball elements do not recirculate, the frictional resistance will not vary significantly resulting in smooth, high precision operation. Additionally, the

ball cage greatly reduces the contact noise of the rolling elements bringing about a low-noise operation.

High Accuracy

The ball raceway grooves of each of the bed and table are processed through simultaneous precision machining resulting in minimal processing errors, and bringing about extremely smooth, precision linear movement.

Stainless Steel Structure

The SYBS type is made of all stainless steel components. This allows for use in corrosive or high temperature applications. The SYBS is a perfect component for vacuum or clean room environments.

Figure G-20 Structure of SYBS type

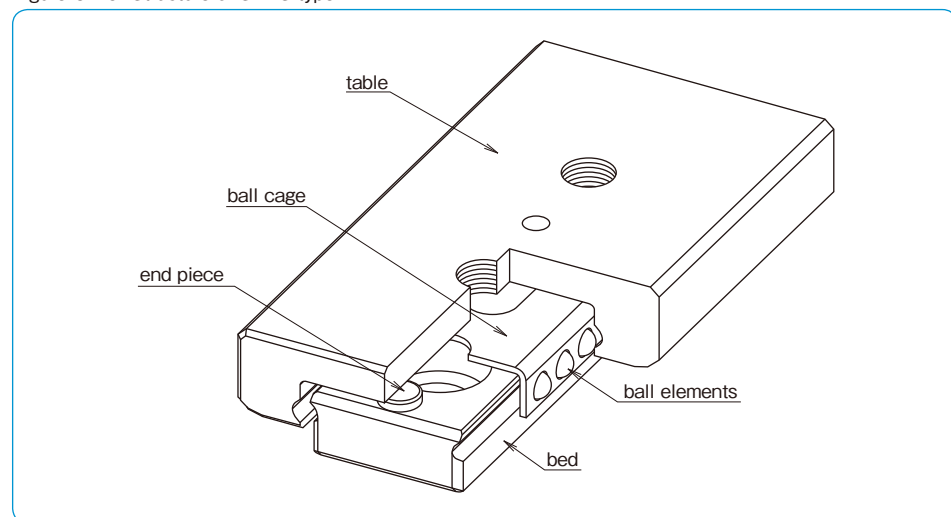

ACCURACY

Table G-7 shows the accuracy of the SYBS miniature slide table.

The deviation is measured as Figure G-21 illustrates. Dial indicators are placed to the center of the table's top and the reference surface side (opposite from the NB mark) and then the table is moved the full stroke without any load.

Table G-7 Accuracy unit/mm

item	tolerance
height H	±0.020
width W	±0.025
deviation from center of surface C	0.004
deviation from center of surface D	0.006

Figure G-21 Accuracy Measurement Method

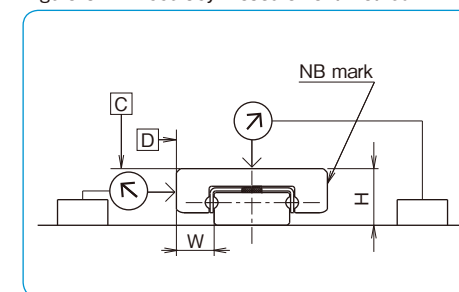

LOAD RATING

The load rating of the miniature slide table varies depending on the direction of the applied load.

Table G-8 Change of Load Rating Corresponding to Load Direction

basic dynamic load rating	vertical direction	1.00×C
	horizontal direction	1.13×C
basic static load rating	vertical direction	1.00×Co
	horizontal direction	1.19×Co

Figure G-22 Direction of Load

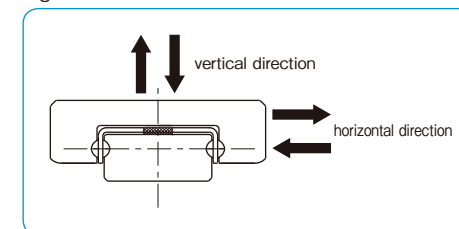

RATED LIFE

The life of an NB miniature slide table is calculated using the following equations:

Rated Life

$$L = \left(\frac{f_r}{f_w} \cdot \frac{C}{P} \right)^3 \cdot 50$$

L: rated life (km) f_r: temperature coefficient
 f_w: applied load coefficient C: basic dynamic load rating (N)
 P: applied load (N)
 * Refer to page Eng-5 for the coefficients.

Life Time

$$L_h = \frac{L \cdot 10^3}{2 \cdot \ell_s \cdot n_i \cdot 60}$$

L_h: life time (hr) ℓ_s: stroke length (m)
 n_i: number of cycles per minute (cpm)

MOUNTING

Mounting Surface Profile

In most general installations, the miniature slide table is mounted by pushing the reference surface of the bed and table against a shoulder that is set up on the mounting surface. Machined escape grooves should be used in the corners of the shoulder (as illustrated in Figure G-23) so that the corners will not interfere with the reference surfaces of the bed and table. Table G-9 lists the recommended shoulder heights of the mounting reference surfaces.

When installing the miniature slide table without providing machined escape grooves, the corner radius should be realigned as illustrated in Figure G-24. Table G-10 lists the values of the corner radius of the mounting surface.

Figure G-23 Mounting Surface Profile-1

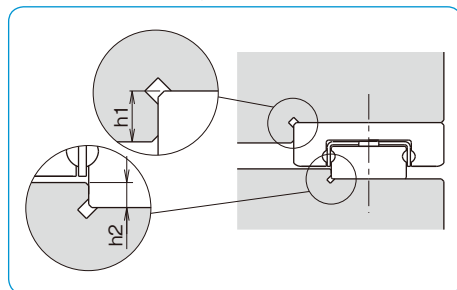
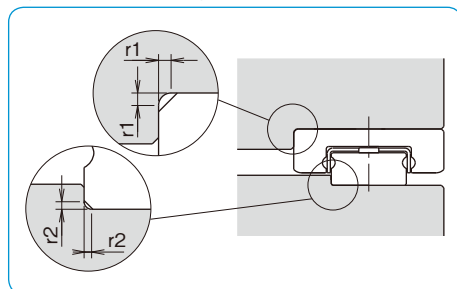

Figure G-24 Mounting Surface Profile-2



Recommended Torque Value

The bed should be tightened with a consistent torque by using a torque wrench. Table G-11 lists the recommended torque.

size	torque
M1	0.03
M1.6	0.15
M2	0.3

(for stainless steel screw A2-70)

Table G-9 Shoulder Height on Mounting Reference Surface unit/mm

part number	shoulder height for table h1	shoulder height for bed h2
SYBS 6	1.0	0.5
SYBS 8	1.2	0.8
SYBS12	1.5	0.8

Table G-10 Maximum Corner Radius unit/mm

part number	mounting surface for table	mounting surface for bed
	r1	r2
SYBS 6	0.1	0.05
SYBS 8	0.15	0.1
SYBS12	0.15	0.1

Figure G-25 Profile of SYBS Bed

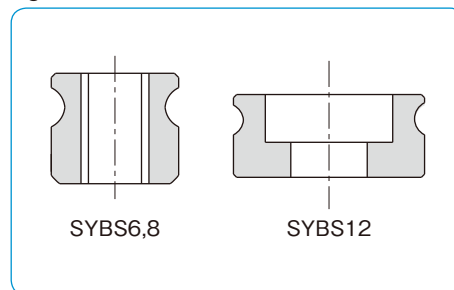

Mounting Example and Mounting Screw

All the mounting holes are fully through-hole. Mount the SYBS type as illustrated in Figure G-26 after considering the size of mounting screw, the maximum penetration depth, and the height of the bed. Make certain that the mounting screws do not interfere with the ball cage; otherwise, the accuracy and travel life will be affected adversely. Special screws for SYBS type are available from NB. Please refer to Table G-12 for dimensions of mounting screws.

Figure G-26 Mounting Example

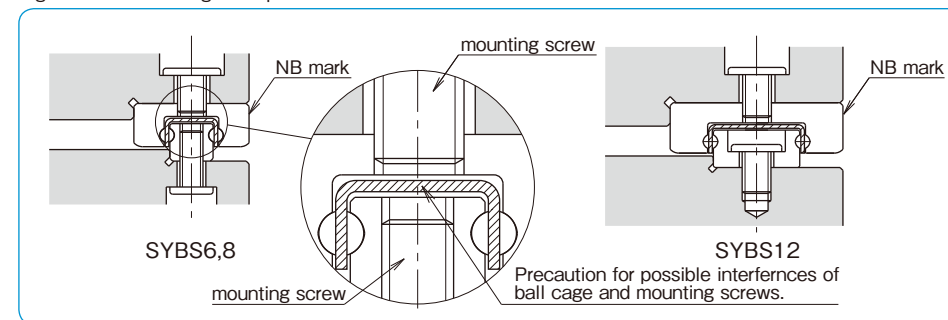
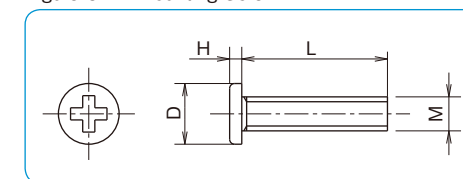

Table G-12 Mounting Screw (stainless steel)

M (size)	D mm	H mm	pitch mm	L mm
M1	1.8	0.45	0.25	5
M1.4	2.5	0.5	0.3	6
M1.6	2.3	0.5	0.35	4, 5, 6
M2	3	0.6	0.4	6

Figure G-27 Mounting Screw



USE AND HANDLING PRECAUTIONS

Preload

The SYBS miniature slide table is provided with a slightly positive clearance type only.

End Piece

On both ends of the SYBS miniature slide table bed section, screws are attached to prevent the ball cage from escaping. Please note that the screws are designed only to prevent the ball cage from escaping and are not intended for the use as a mechanical stopper. The ball cage may become deformed on contact with the stopper and this will result in a negative affect of the accuracy and travel life.

Lubrication

NB miniature slide table SYBS type is supplied with an initial application of lithium soap grease and therefore is ready for immediate use. Make sure to relubricate with a similar type of grease periodically according to the operating conditions. For use in clean rooms or vacuum environments, miniature slide tables without grease or with customer specified grease are available. NB also provides low

dust generation grease. Please refer to page Eng-39 for details.

Ball Cage Slippage

When a miniature slide table is operated at high speed; when offset loads or vibrations are present, the ball cage may deviate from the normal position. Under general operating conditions it is suggested that the motion speed be kept under 30m/min. It is recommended that the table be cycled to perform maximum full stroke several times during operation. This will allow the ball cage to be returned to its normal central position.

Allowable Load

The allowable load is a load under which the sum of elastic deformation of the rolling element and the raceway in the contact area subject to the maximum contact stress is small enough to guarantee smooth rolling movement. When very smooth and highly accurate liner motion is required, make sure to use the product within the allowable load values.

SYBS TYPE

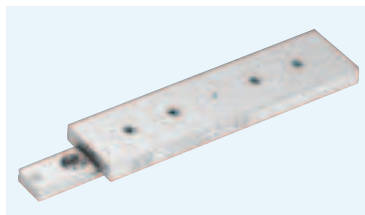

part number structure

example SYBS 8-31

SYBS type

size

table length

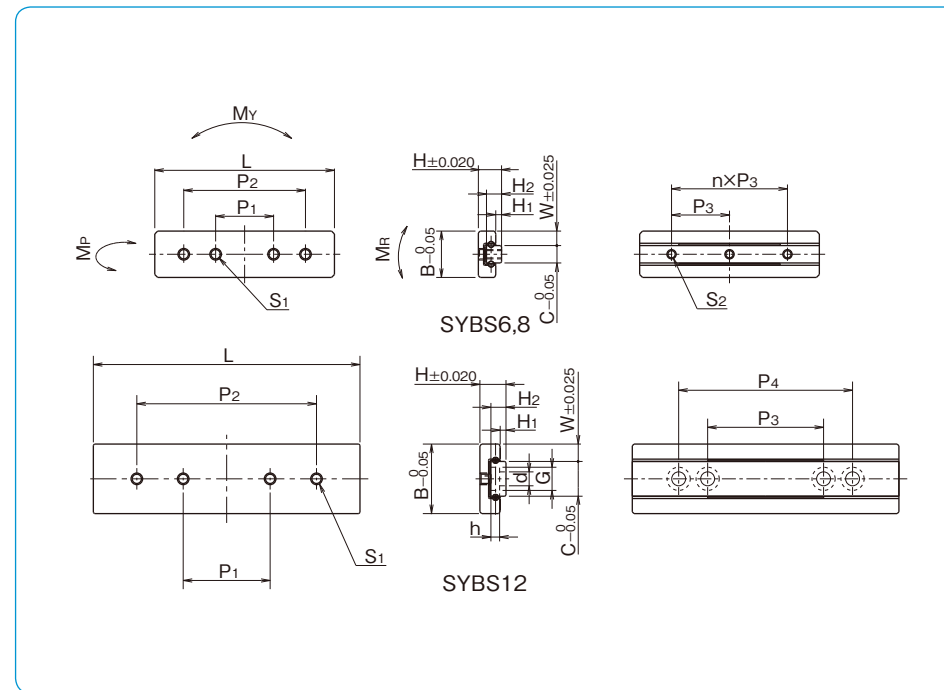

part number	major dimensions				tabel-top dimensions						
	H	W	H ₁	stroke	B	L	P ₁	P ₂	S ₁	maximum screw penetration depth mm	
mm	mm	mm	mm	mm	mm	mm	mm	mm	mm		
SYBS 6-13	3.2	2	0.7	5	6	13	6.0	—	M1.4	0.5	
SYBS 6-21				12		21	10.0	—			
SYBS 8-11	4	2.5	1	4	8	11	5.5	—	M2	0.7	
SYBS 8-21				12		21	10.0	—			
SYBS 8-31				18		31	10.0	21			
SYBS12-23	4.5	3	1	12	12	23	8.0	—	M2	1.2	
SYBS12-31				18		31	15.0	—			
SYBS12-46				28		46	15.0	31			

※1: Custom mounting screws are provided with the SYBS-12 type only. Other screw sizes are also available. (Please refer to page G-49)

H ₂	C	bed-surface dimensions					basic load rating		allowable load	allowable static moment			mass g	size
		d×G×h	S ₂	P ₃	n	P ₄	C dynamic	C ₀ static		F N	M _P N·m	M _Y N·m		
mm	mm	mm	mm	mm	mm	mm	N	N	N	N·m	N·m	N·m	g	
2.0	2	—	M1	7	1	—	154	180	60.1	0.21	0.25	0.21	1.4	6-13
				7	2	—	229	315	105	0.57	0.69	0.37	2.2	6-21
2.6	3	—	M1.6	5	1	—	201	211	70.4	0.23	0.28	0.35	2.0	8-11
				10	1	—	368	493	164	1.02	1.22	0.83	3.7	8-21
2.6	6	2.4×4×1.5 ^{※1}	—	10	2	—	473	704	234	1.97	2.35	1.19	5.5	8-31
				15	1	—	404	563	187	1.30	1.55	1.80	7.6	12-23
				15	1	—	473	704	234	1.97	2.35	2.25	10.2	12-31
				20	—	30	658	1,120	375	4.80	5.72	3.60	15.2	12-46

1N≒0.102kgf 1N·m≒0.102kgf·m

GONIO WAY

The NB gonio way is a curved cross roller slide way. It is a curved motion bearing utilizing low-friction, non-recirculating precision rollers. It is used when there is a need to change the gradient or obtain an accurate gradient angle without changing the center of rotation in high-precision optical and measurement equipment.

STRUCTURE AND ADVANTAGES

The NB gonio way RVF type consists of curved tracking bases with precisely ground V-grooves and flat installation surfaces, as well as curved roller cages. The NB gonio way RV type consists of curved rails with precisely machined V-grooves and curved roller cages. Precision rollers are employed as the rolling elements, since the rolling elements do not recirculate, the frictional resistance will not vary significantly, providing curved movement with extremely low frictional resistance.

Low Frictional Resistance and Minute Motion

The precision grinding and curved roller cage allow for extremely low frictional resistance. The negligible difference between static and dynamic frictions allows the gonio way to follow minute movements accurately, realizing curved movement of high accuracy.

Low Noise

Since NB gonio way employs a non-recirculating design, there is no noise from the circulating area. In addition, the curved roller cage realizes quiet operation without contact noise between the rolling elements.

High Rigidity and High Load Capacity

The rollers provide a larger contact area and less

elastic deformation compared to the ball elements. Additionally, since the rollers do not recirculate, the effective number of rotating elements is larger, resulting in high rigidity and high load capacity.

Flat Installation Surface

The flat installation surfaces of the RVF type do not require complicated machining of tables and beds when installing the product. As a result, machining costs can be reduced greatly.

Same Rotation Center

The curved V-grooves, which are finished with a precise grinding process, provide an accurate center of rotation. Furthermore, the products are composed to provide identical rotation centers when products of each size are installed to two axes. (refer to Table G-17.)

Figure G-28 Structure of Gonio Way RVF type

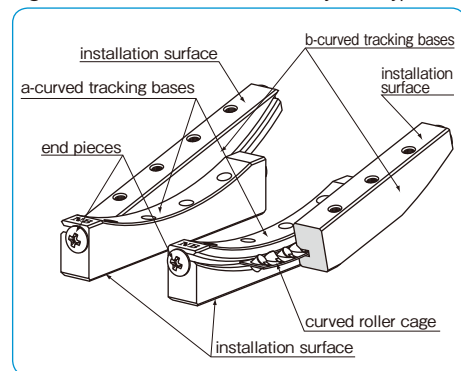
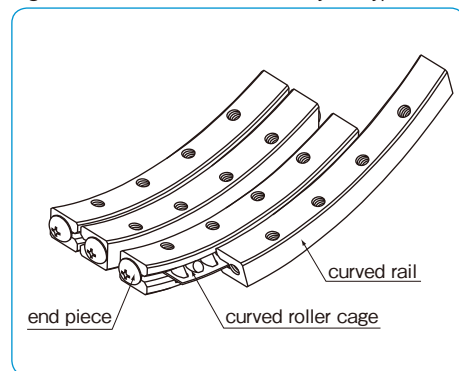

Figure G-29 Structure of Gonio Way RV type



ACCURACY OF RVF TYPE

The accuracies of the gonio way RVF type are represented by mutual dimensional errors of four rails, which are measured along the overall length using the procedure as shown in Figure G-30.

Table G-13 Accuracy unit/μm

part number	mutual error between A and B	mutual error between E and F
	mutual error between C and D	mutual error between H and I
RVF2050- 70	10	10
RVF2050- 87		
RVF2050-103		
RVF2050-120		
RVF3070- 85		
RVF3070-110		
RVF3100-125		
RVF3100-160		

Figure G-30 Accuracy Measuring Method

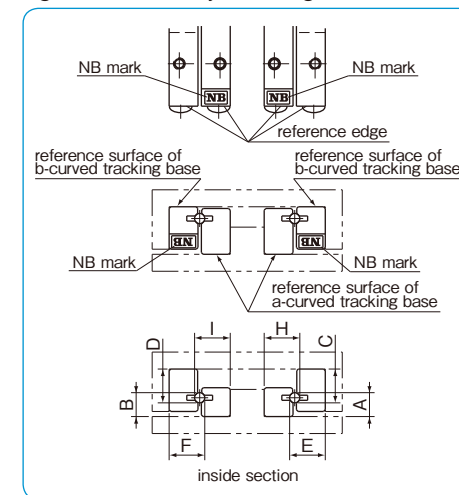

ACCURACY OF RV TYPE

The accuracies of the gonio way RV type are represented by mutual dimensional errors of four rails, which are measured along the overall length using the procedure as shown in Figure G-31.

Table G-14 Accuracy unit/μm

part number	accuracy
RV2040- 50	10
RV2060- 60	
RV3070- 90	
RV3070-110	
RV3100-160	

Figure G-31 Accuracy Measuring Method

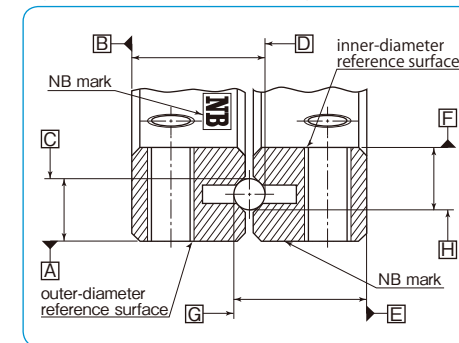

The reference surfaces are located on the opposite side of the NB mark. There are inner reference surface and outer reference surface in one set of RV.

RATED LIFE

The life of a gonio way is obtained using the following equations.

Rated Life

$$L = \frac{90}{\theta} \times \left(\frac{fr}{fw} \times \frac{C}{P} \right)^{\frac{10}{3}}$$

L: travel life (10⁶cycles) θ: rotating angle (degree)
 C: basic dynamic load rating (N) P: applied load (N)
 fr: temperature coefficient fw: applied load coefficient
 ※Refer to page Eng-5 for the coefficients.

Life Time

$$L_h = \frac{L \times 10^6}{60 \times n}$$

Lh: life time (hr)
 n: number of cycles per minute (cpm)

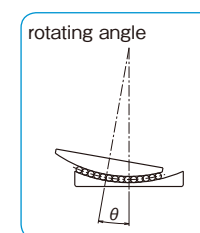

MOUNTING OF RVF TYPE

Accuracy of Mounting Surface

To maximize the performance of NB gonio way, it is important to finish the installation surface with high accuracies.

- Parallelism of surface 1 against surface A
- Perpendicularity of surface 2 against surface A
- Perpendicularity of surface 5 against surface A
- Parallelism of surface 3 against surface B
- Perpendicularity of surface 4 against surface B
- Perpendicularity of surface 6 against surface B
- Parallelism of surface 2 against surface C
- Parallelism of surface 4 against surface C

Figure G-33 Example of Installation of RVF type

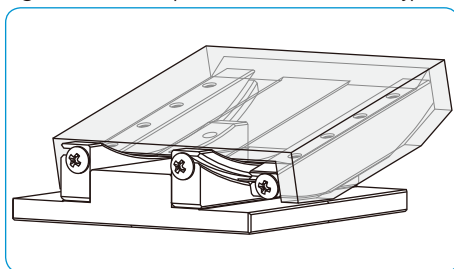

Installation Procedure

Setting the curved tracking bases temporarily

- (1) Remove burrs, stains, and dust from the installation surfaces of the curved tracking bases of tables and beds. Foreign particles must be kept out of the assembly work as well.
- (2) Apply low viscosity oil to contact surfaces, check the reference edges of an a-curved tracking base and bed, and then tighten the screws temporarily. (Figure G-34a)
- (3) Align the reference edges (NB mark side) of a b-curved tracking base and an a-curved tracking base to the same orientation. Then, insert the curved roller cages between the curved tracking bases at the center area. Make sure that the curved roller cages will not interfere with the curved raceway grooves of the curved roller tracking bases. (Figure G-34b)
- (4) Check the reference edge of the table, set the table over the b-curved tracking base, and then secure the table temporarily. (Figure G-34c)

Figure G-32 Accuracy of Mounting Surface

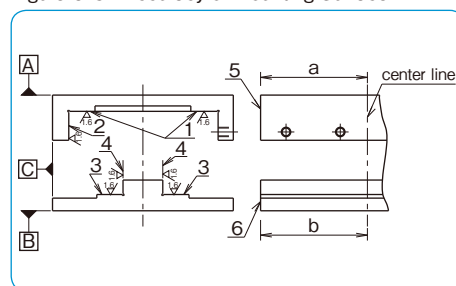
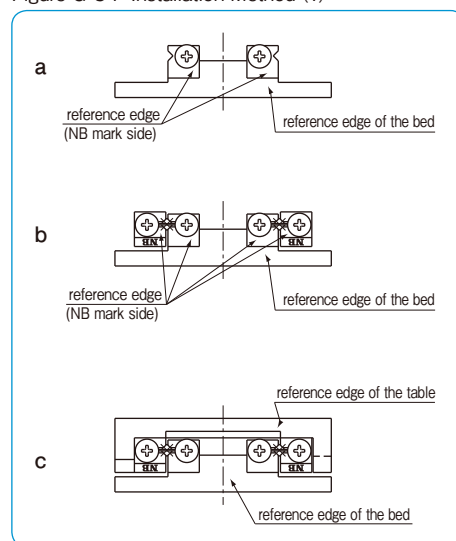

Figure G-34 Installation Method (1)



Setting four curved tracking bases in parallel position

- (5) Move the table to the maximum stroke ends of both sides and adjust the setting so that the curved roller cage is positioned at the center of the curved tracking base.
- (6) Move the table to the center position and tighten the adjustment screws with ※slightly strong torque by using a torque wrench. (Figure G-35d)
 ※"Slightly strong torque" here means slightly stronger than the torque at which the oscillation of the dial indicator is stabilized at the minimum value when the table is moved right and left, or when pressure is applied to the rolling direction while the dial indicator is attached to the side face (reference side) of the table. (Figure G-35i)
- (7) Move the table to the maximum stroke end of one side and tighten the adjustment screws on the curved roller cage with the same torque as in step (6). (Figure G-35e)
- (8) Move the table to the maximum stroke end of the other side and tighten the adjustment screws with a torque wrench by repeating the procedure above. (Figure G-35f)

Securing the curved tracking bases

- (9) Mount an edge reference plate between the reference edge of the a-curved tracking base and end piece, press it against the reference edge of the bed, and then tighten only the mounting screws in the middle. (Figure G-35g)
- (10) Repeat the procedure above to mount an edge reference plate between the reference edge of the b-curved tracking base and the end piece. Press it against the reference edge of the bed, and then tighten only the mounting screws in the middle. (Figure G-35h) In order to maintain parallelism of curved tracking bases, do not cycle the table during this process and make sure that there is no clearance between the edge of the table and the edge reference plate.
- (11) Secure the rest of the mounting screws on the curved roller cage one by one by moving the table as instructed in steps (7) and (8).

Adjusting the preload

- (12) Move the table to the right and left with the test indicator attached to the side face of the table (reference side). Or, apply pressure in the rolling direction and confirm that the oscillation of the indicator is stabilized at the minimum level. (Figure G-35i)
- (13) Return the mounting screws on the b-curved tracking base at the adjustment screw side to the temporary setting.
- (14) Return the table to the center position, slightly loosen the adjustment screws in the middle, and then gradually loosen the adjustment screws on the curved roller cage while moving the table as instructed in steps (7) and (8). Make sure not to reduce the preload too much.
- (15) Finally, secure the b-curved tracking base at the adjustment screw side, which has been installed temporarily. Secure the mounting screws on the curved roller cage one by one by moving the table as instructed above.

Figure G-35 Installation Method (2)

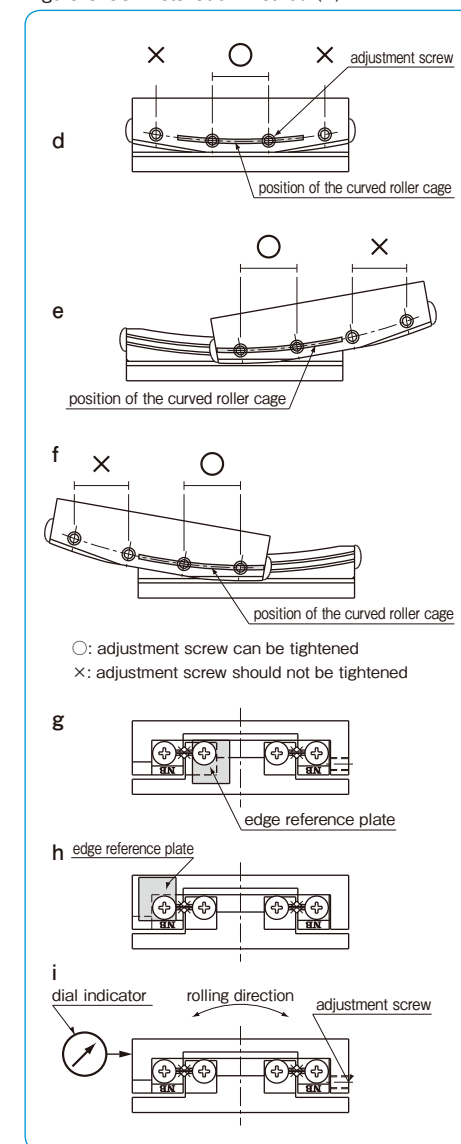

Table G-15 Recommended Torque for Mounting Screw

size	tightening torque
M2.5	0.5
M3	1.1

(for stainless steel screw A2-70)

MOUNTING OF RV TYPE

Accuracy of Mounting Surface

The accuracy of surfaces 1, 2, 3, and 4 (Figure G-36) directly affect the motion accuracy. To maximize the performance of NB gonio way, it is important to finish the installation surface with high accuracies.

Figure G-36 Accuracy of Mounting Surface

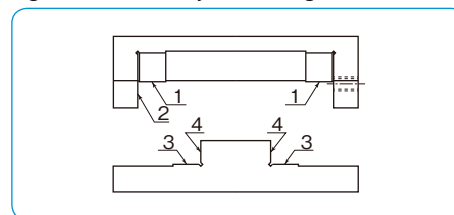
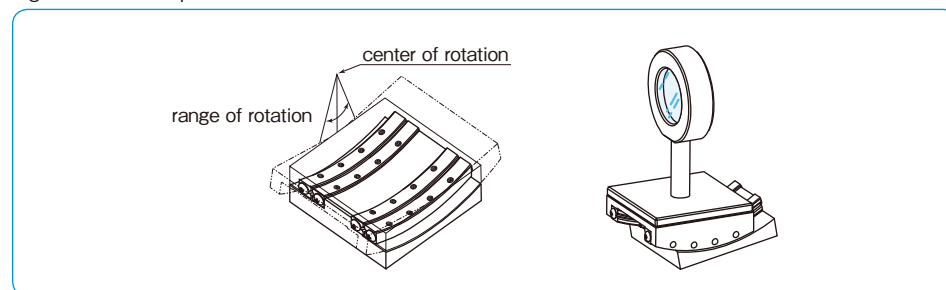

Figure G-37 Example of Installation



Installation Procedure

- (1) Remove burrs, dirt, dust, etc. from the table and the installation surfaces of the bed.
- (2) Apply a low viscosity oil to contact surfaces. Fix the rail ①inner-diameter reference surface, ②outer-diameter reference surface and ③outer-diameter reference surface by tightening screws to the specified torque. (Table G-16, Figure G-38a)
- (3) Temporarily attach the rail ④inner-diameter reference surface on curved rail to the adjustment side. (Figure G-38b)
- (4) Remove the end pieces on one side of the rails and insert roller cages to the center. (Figure G-38c)
- (5) Re-attach end pieces.
- (6) Move the table to the right and left (in the direction of the stroke) to position roller cages at the center of the curved rails.
- (7) Set an indicator at the side of the table on the reference surface. (Figure G-38d)
- (8) Move the table to one of the stroke ends and tighten the adjustment screws slightly. (Figure G-39e)

Figure G-38 Installation Method (1)

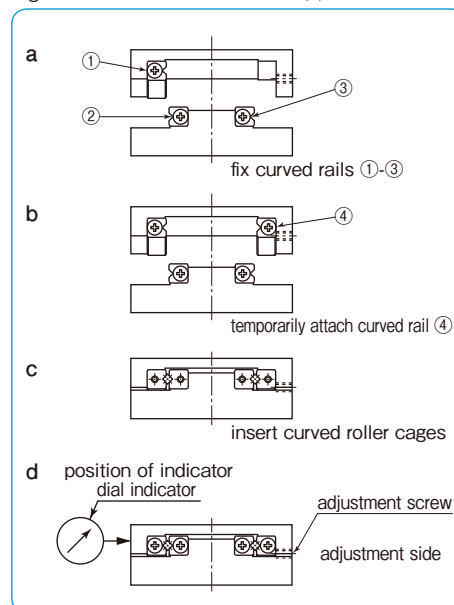

- (9) Move the table fully to the other stroke end and tighten the adjustment screws slightly. (Figure G-39f)
- (10) Move the table to the center and lightly tighten adjustment screws. (Figure G-39g)
- (11) Repeat steps (8)~(10) until there is no clearance around the table. If there is no clearance, the indicator will show a minimum fluctuation value when the table is moved to the right and left. Exercise care so as not to apply an excessive preload.
- (12) Repeat steps (8)~(10) and tighten the adjustment screws uniformly by using a torque wrench.
- (13) Fix the rail ④inner-diameter reference surface. Tighten the mounting screws sequentially by moving the table in the same manner as with the adjustment screws.

Table G-16 Recommended Torque for Mounting Screw

size	torque
M3	1

(for stainless steel screw A2-70)

Figure G-39 Installation Method (2)

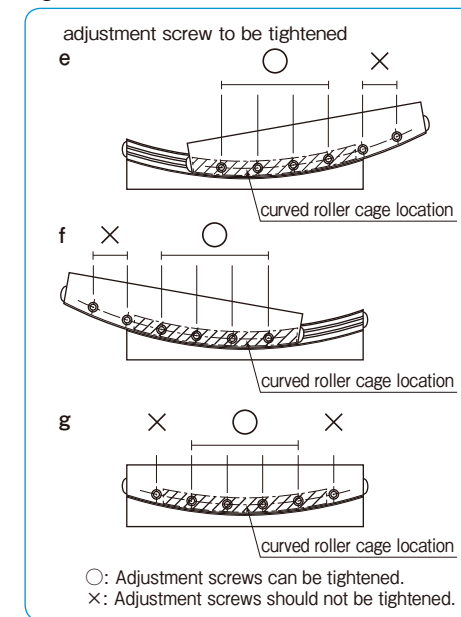

RVF TYPE 2 AXES AND SPECIAL SPECIFICATIONS

When incorporating RVF type units onto two axes as illustrated in Figure G-40, adjust the height of one lifting axis as instructed in Table G-17. Then, adjust dimension b (the height of the installation surface of the a-curved tracking base) in Figure G-40 according to the table in order to obtain the identical rotation center for the two axes. In addition, requests can be made for custom specifications including table units fitted for two axes, non-standard lengths for curved tracking bases, the radius of rotation, the rotation range, and the number of rollers. Contact NB for further information.

Table G-17 Two Axes Specification unit/mm

part number combination	a	R ₁	R ₂
RVF2050- 70 RVF2050- 87	17	70	87
RVF2050-103 RVF2050-120	17	103	120
RVF3070- 85 RVF3070-110	25	85	110
RVF3100-125 RVF3100-160	35	125	160

Figure G-40 Two Axes Specification

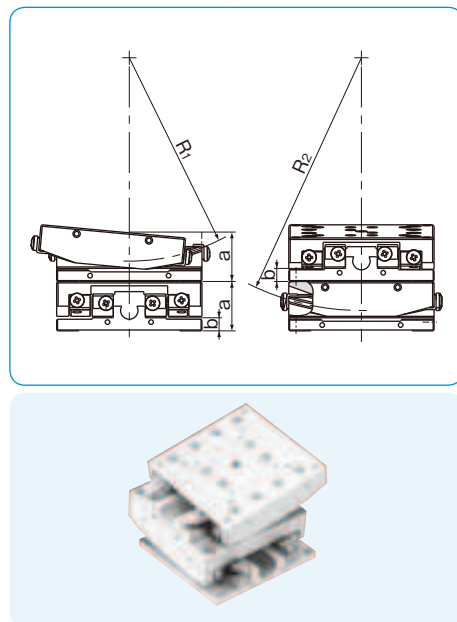

USE AND HANDLING PRECAUTIONS

Lubrication

NB gonio ways are lubricated using lithium soap based grease prior to shipment, so they can be used immediately. Make sure to relubricate with a similar type of grease periodically according to the operating conditions. NB also provides low dust generation grease for the linear system. Please refer to page Eng-39 for further details.

Dust Prevention

If a foreign matter, such as dust and dirt, enters the inside of the NB gonio way, it will deteriorate the accuracy and life of the system. A gonio way used in a harsh environment should be protected with a cover.

Operating Environment

The recommended operating temperature range of the NB gonio way is -20°C to 110°C.

Adjustment

Inaccuracy in mounting surface or improper adjustment of preload will reduce the motion accuracy, resulting in skewing and shortening of gonio way life. The adjustment should be carried out carefully.

Cage Slippage

When used under high-speed, unbalanced-load, or vibrational conditions, cage slippage may occur. The stroke length should be determined with sufficient margin, and an excessive preload should not be applied.

End Pieces

End pieces are attached to each end of the NB gonio way to prevent removal of the curved roller cage. Do not use as a mechanical stopper.

Careful Handling

Dropping the NB gonio way causes the rolling elements to make dents in the raceway surface. This will prevent smooth motion and will also affect accuracy. Be sure to handle the product with care.

Use as a Set

The accuracy of the rails has been matched within each set. Note that the accuracy will be affected when the rails of different sets are combined.

Allowable Load

The allowable load is a load under which the sum of elastic deformation of the rolling element and the raceway in the contact area subject to the maximum contact stress is small enough to guarantee smooth rolling movement. When very smooth and highly accurate motion is required, make sure to use the product within the allowable load.

RVF TYPE

— Gonio Way flat-installation-surface —

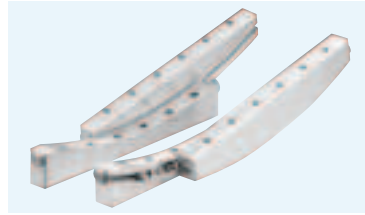

part number structure

example **RVF 3 100 125 16Z**

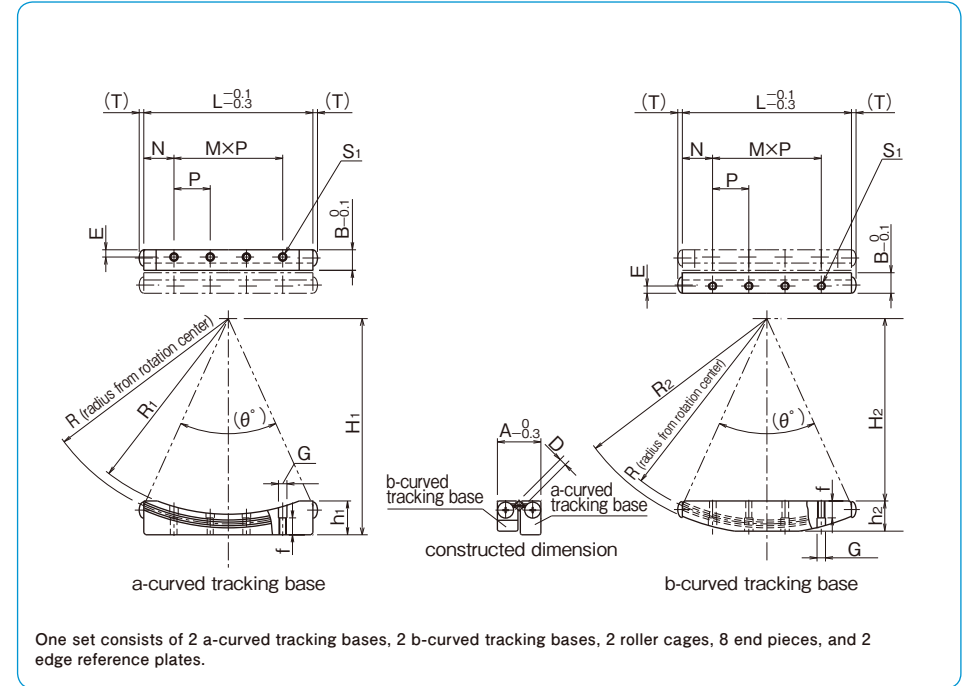
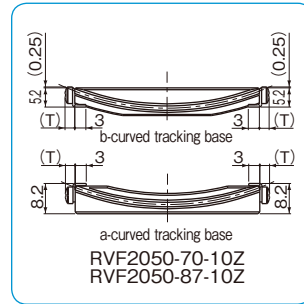
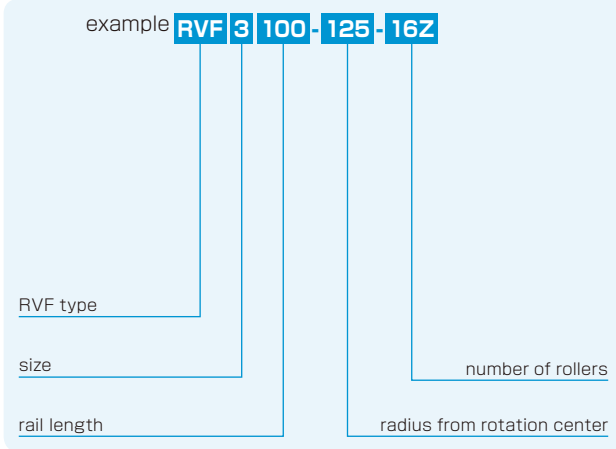

part number	rotation range	roller diameter D mm	number of rollers Z	major dimensions									
				L mm	R mm	R ₁ mm	R ₂ mm	H ₁ mm	H ₂ mm	h ₁ mm	h ₂ mm	A mm	B mm
RVF2050- 70-10Z	± 5°	2	10	50	70	67	73	72.5	64.5	7.5	7.5	15	7.25
RVF2050- 87-10Z			10		87	84	89.5	89.5	81.5	7.5	7.5		
RVF2050-103-10Z			10		103	100	106	105.5	97.5	7.5	8		
RVF2050-120- 9Z			9		120	117	123	122.5	114.5	7.5	8		
RVF3070- 85-10Z	±10°	3	10	70	85	81	89	89.5	75.5	14	12.5	18	8.5
RVF3070-110-10Z			10		110	106	114	114.5	100.5	12.8	12.5		
RVF3100-125-16Z			16		125	121	129	129.5	110.5	17.5	18		
RVF3100-160-14Z			14		160	156	164	164.5	145.5	15	18		

※ Please refer to page G-64 for information on cage types.

M×P mm	N mm	E mm	S ₁	f mm	G mm	T mm	θ°	basic load rating			mass (one set) g	part number
								dynamic C N	static C ₀ N	allowable load F N		
3×12.5	6.25	2.5	M2.5	4	3	2.7	41.8°	1,180	2,400	800	66	RVF2050- 70-10Z
							33.3°	1,060	2,430	810	70	RVF2050- 87-10Z
3×13	5.5	3	M3	7	3.5	1.9	28.0°	998	2,440	815	70	RVF2050-103-10Z
							24.0°	751	1,970	657	70	RVF2050-120- 9Z
3×15	12.5	3	M3	7	3.5	1.9	48.6°	2,680	5,530	1,840	182	RVF3070- 85-10Z
							37.1°	2,440	5,620	1,870	182	RVF3070-110-10Z
5×15	12.5	3	M3	7	3.5	1.9	47.1°	3,520	8,850	2,950	327	RVF3100-125-16Z
							36.4°	2,860	7,890	2,630	323	RVF3100-160-14Z

1N≒0.102kgf

RV TYPE

— Gonio Way —

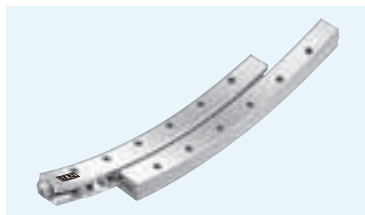

part number structure

example **RV 3 070- 110 - 10Z**

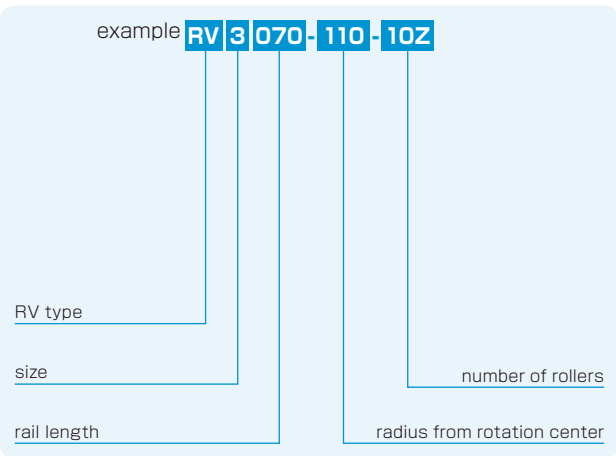

part number	rotation range	roller diameter D mm	number of rollers Z	major dimensions						
				L mm	R mm	R ₁ mm	R ₂ mm	A mm	B mm	C mm
RV2040- 50- 7Z	±10°	2	7	40	50	53	47	15	6	7.25
RV2060- 60-12Z			12	60	60	63	57			
RV3070- 90-11Z	±10°	3	11	70	90	94	86	18	8	8.5
RV3070-110-10Z			10	70	110	114	106			
RV3100-160-14Z			14	100	160	164	156			

※ Please refer to page G-64 for information on cage types.

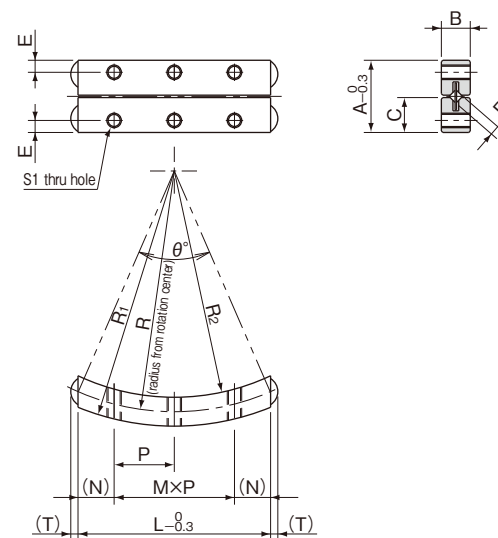

One set consists of 4 curved rails, 2 curved roller cages, and 8 end pieces.

M×P mm	N mm	E mm	S ₁	T mm	θ°	basic load rating			mass (one set) g	part number
						dynamic C N	static C ₀ N	allowable load F N		
2×12.5	7.5	2.5	M3	1.5	47.2°	820	1,440	482	49	RV2040- 50- 7Z
3×12.5	11.25				60.0°	1,490	2,800	936	75	RV2060- 60-12Z
3×15	12.5	3	M3	1.9	45.8°	2,640	5,550	1,850	137	RV3070- 90-11Z
3×15					37.1°	2,440	5,620	1,870	135	RV3070-110-10Z
5×15					36.4°	2,860	7,890	2,630	193	RV3100-160-14Z

1N=0.102kgf

CR TYPE

— Standard Curved Roller Cage —

part number structure

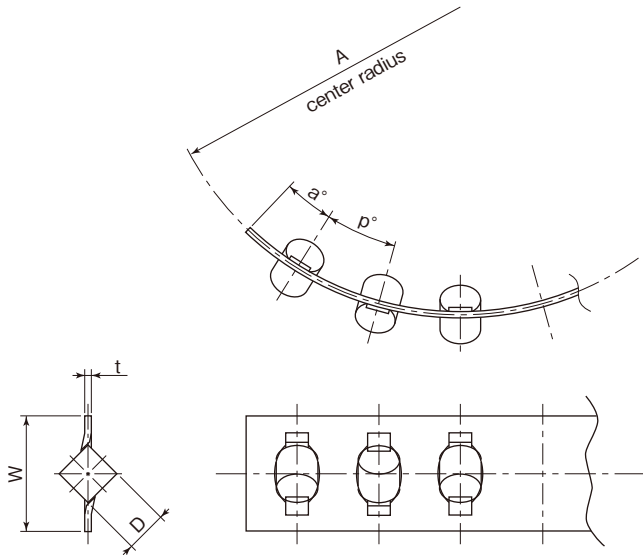
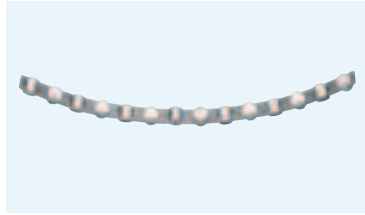
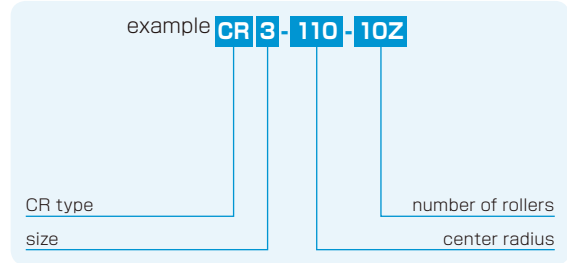

part number	roller diameter		center radius		t mm	w mm	p°	a°	applicable type
	D mm	A mm							
CR2- 50- 7Z	2	50	0.3	5.6	0.3	5.6	4.6°	2.9°	RV
CR2- 60-12Z		60					3.8°	2.4°	RV
CR2- 70-10Z		70					3.3°	2.0°	RVF
CR2- 87-10Z		87					2.6°	1.6°	RVF
CR2-103-10Z		103					2.2°	1.4°	RVF
CR2-120- 9Z		120					1.9°	1.2°	RVF
CR3- 85-10Z	3	85	0.4	7.2	0.4	7.2	3.4°	2.9°	RVF
CR3- 90-11Z		90					3.2°	1.9°	RV
CR3-110-10Z		110					2.6°	1.5°	RVF,RV
CR3-125-16Z		125					2.3°	1.3°	RVF
CR3-160-14Z		160					1.8°	1.0°	RVF,RV

ACTUATOR