

SLIDE BUSH

SLIDE BUSH

The NB slide bush is a linear motion mechanism utilizing the rotational motion of ball elements. Since linear motion is obtained using a simple mechanism, the slide bush can be used in a wide variety of applications, including transportation equipment, food processing equipment, and semiconductor manufacturing equipment.

STRUCTURE AND ADVANTAGES

The outer cylinder of slide bush contains a ball retainer that is perfectly designed to control the circulation of ball elements, resulting in smooth linear motion.

Compact Mechanism

The NB slide bush uses a round shaft for the guiding axis, resulting in space-saving, which allows for compact designs.

A Wide Variety of Shapes and Installation Methods

The NB slide bush is available in various types, standard, clearance-adjustable, open, flange, etc., for a various applications.

Selection According to Environment

NB slide bushes are available in standard and anti-corrosion types. Available options include steel-retainer suitable for use in harsh environments and resin retainer for low acoustic, low-cost requirement. Other options can be specified according to the application requirements.

Compatibility

The NB slide bush is fully compatible with a variety of shaft types.

Low Friction

The raceway surface is precision ground. Since the

contact surface between the ball elements and the raceway surface is minimized, the NB slide bush provides low friction compared to other linear motion mechanisms.

GM Series

The GM slide bush makes efficient use of resin sub-parts making it possible to achieve an overall weight reduction of 30~50% compared with the SM slide bush. The ball return section is made of resin material, which serves for low noise operation. Also, cost-effectiveness expands the use of slide bush in many applications.

Block Type Series

Block type series is a unit of NB slide bush and a block type housing. A variety of block types are available such as precision-machined blocks, resin-made blocks, and cost-effective units, each contributes to higher accuracy, light-weight, and low-cost and design-time saving, respectively.

FIT Series

FIT series is a combination of NB slide bush and precision-machined shaft. The best-fit between slide bush and shaft achieves a smooth, high-accuracy performance meeting the customer requirements. (see page F-16)

Figure C-1 Basic Structure of NB Slide Bush (SM, KB, SW)

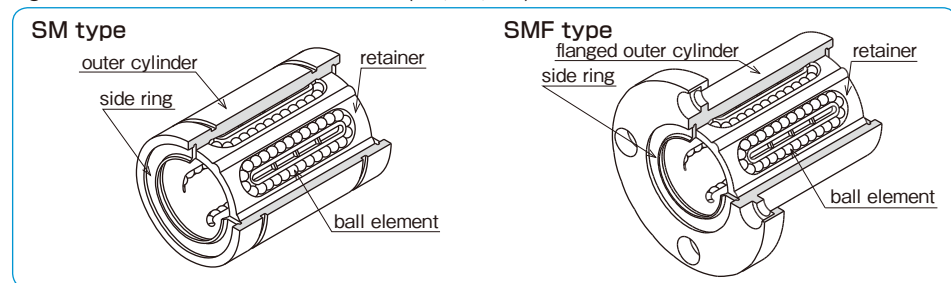
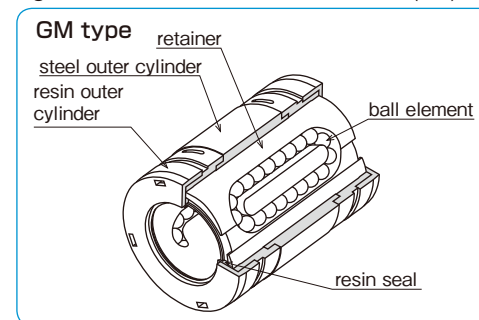

Figure C-2 Basic Structure of NB Slide Bush (GM)



TYPES

Table C-1 Type (1)

type		standard	anti-corrosion	page
standard type		SM	SMS	C- 14
		KB	KBS	C- 68
		SW	SWS	C- 88
clearance-adjustable (AJ) type		SM-AJ	SMS-AJ	C- 16
		KB-AJ	KBS-AJ	C- 70
		SW-AJ	SWS-AJ	C- 90
open (OP) type		SM-OP	SMS-OP	C- 18
		KB-OP	KBS-OP	C- 72
		SW-OP	SWS-OP	C- 92
long type		SM-G-L	—	C- 20
double-wide type		SM-W	SMS-W	C- 22
		KB-W	KBS-W	C- 74
		SW-W	SWS-W	C- 94

Table C-2 Type (2)











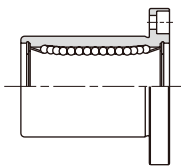







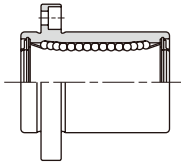



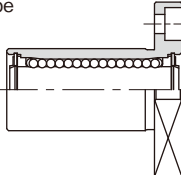

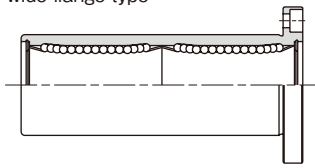





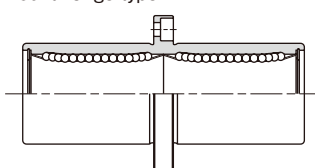

type		standard	anti-corrosion	page
flange type 		SMF	SMSF	C- 24
		KBF	KBSF	C- 76
		SWF	SWSF	C- 96
		SMK	SMSK	C- 26
		KBK	KBSK	C- 78
		SWK	SWSK	C- 98
		SMT	SMST	C- 28
flange type with pilot end 		SMF-E	SMSF-E	C- 30
		SMK-E	SMSK-E	C- 32
		SMT-E	SMST-E	C- 34
long flange type 		SMK-G-L	-	C- 36
double wide flange type 		SMF-W	SMSF-W	C- 38
		KBF-W	KBSF-W	C- 80
		SWF-W	SWSF-W	C-100
		SMK-W	SMSK-W	C- 40
		KBK-W	KBSK-W	C- 82
		SWK-W	SWSK-W	C-102
		SMT-W	SMST-W	C- 42
center mount flange type 		SMFC	SMSFC	C- 44
		KBFC	KBSFC	C- 84
		SMKC	SMSKC	C- 46
		KBKC	KBSKC	C- 86
		SMT-C	SMST-C	C- 48
double-wide pilot end flange type 		SMF-W-E	SMSF-W-E	C- 50
		SMK-W-E	SMSK-W-E	C- 52
		SMT-W-E	SMST-W-E	C- 54

Table C-3 Type (3)



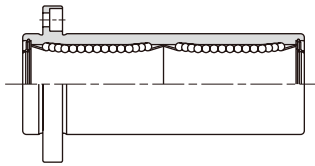



type		standard	anti-corrosion	page
triple wide flange type 		TRF	-	C- 56
		TRK	-	C- 58
※ Outer cylinder is treated with electroless nickel plating				
triple-wide intermediate position flange type 		TRFC	-	C- 60
		TRKC	-	C- 62
※ Outer cylinder is treated with electroless nickel plating				
triple-wide pilot end flange type 		TRF-E	-	C- 64
		TRK-E	-	C- 66
※ Outer cylinder is treated with electroless nickel plating				

Table C-4 Type (4) GM Series

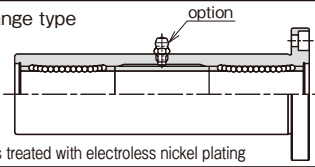
type		standard	page
GM/GW single type 		GM	C- 104
		GW	C-106
GM double-wide type 		GM-W	C-105

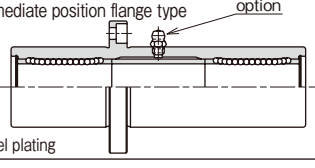
BLOCK SERIES

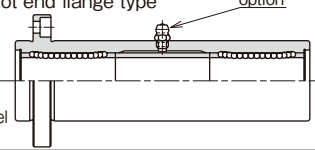
SMA · AK · SMB · SWA Type

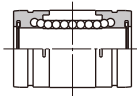
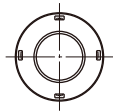
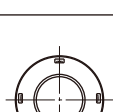
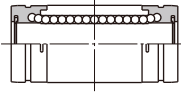
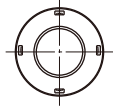
This type is the most commonly used standard type. The housing is made of aluminum alloy. The wide (W) type is also available for SMA and AK types.

SMJ · SWJ Type

Clearance-adjustment is achieved by creating a slit on the SMA/SWA type housing. Less clearance between block and shaft results in higher positioning accuracy by tightening the adjustment screw.

RBW Type

The housing is made of ABS resin for light-weight and low-cost. Inside is an inch sized bush of a resin retainer type with seals.

Metric Series

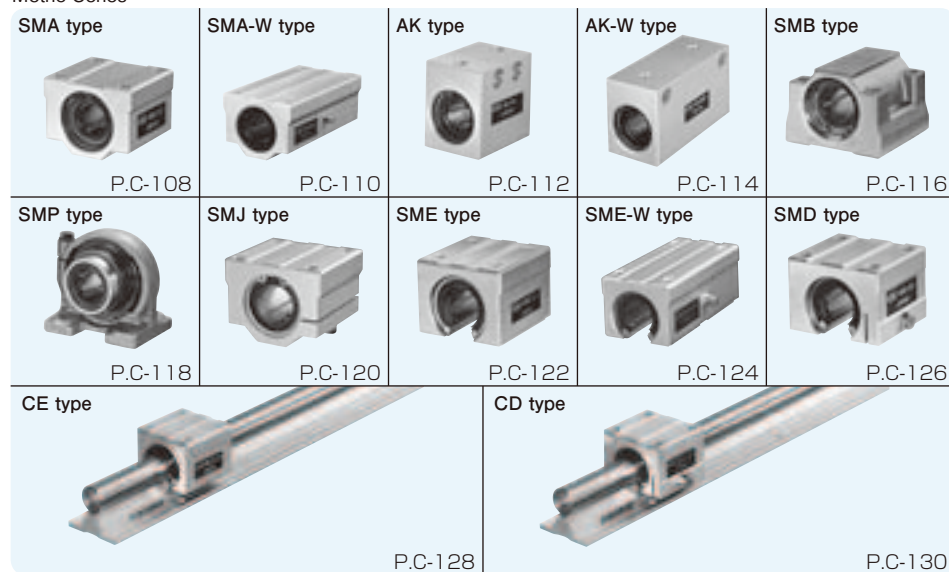

Inch Series

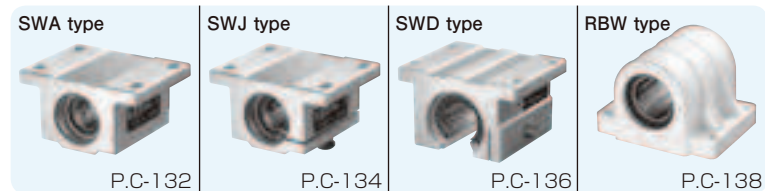

SMP Type

The housing has a self-aligning feature. This feature will absorb inaccuracy of the installation base so that a smooth movement is expected.

SME · SMD · SWD Type

Open type housing allows a support from below so that a deflection of the shaft is minimized for high loading or long-stroke applications. The wide(W) type is also available for SME type.

CE · CD Type

This type is a unit of block(s), shaft, and support rail that contributes to a total cost reduction. The maximum length is 2,000mm for the support rail and for the shaft the maximum length is 4,500mm.

SPECIFICATIONS

Series

The NB slide bush is available in three primary dimensional series, each with different dimensions and tolerances depending on the location of use. Please select the series that is most appropriate for your location.

Allowable Load

NB slide bushes are categorized into three functional types depending on the number and location of retainers: single, double, and triple. Table C-6 shows load ratings and static moment in comparison. The single type uses only one retainer, so when a moment load is to be applied, the double or triple type is recommended.

Material

The outer cylinder of standard type is made of bearing steel and the outer cylinder of anti-corrosion type is made of Martensitic stainless steel. The retainer is available in steel (stainless steel for anti-corrosion), and resin for low acoustic operation. The steel retainer is made of one plate (seamless type).

Seal

The seals prevent dust from entering the slide bush in order to retain the motion accuracy, resulting in a long life time. The UU type is a standard option that has seals on both sides. The U type has a seal on one side only and is available for the standard, clearance adjustable, and open types. Nitril rubber, which has low wear and good sealing characteristics, is used as the seal material. * Resin seals are used for GM series.

For a high temperature application, fluororubber seals are available on the SM series size 6 to 30. Please contact NB for details.

Table C-5 Series and Use Location

series	location				
	Japan	Asia	Europe	North America	
metric	SM	◎	◎	○	○
	GM	○	○	◎	◎
	KB	○	○	○	◎
inch	SW	○	○	○	◎

◎ generally used ○ rarely used

Table C-6 Load Comparison

type	basic dynamic load rating	basic static load rating	allowable static moment
single	1	1	1
long	1.3	1.8	approx. 4
GM-W	1.6	2	approx. 4
SM double	1.6	2	approx. 6
triple	1.6	2	approx.21

※ The single type is designated as "1" for comparison purposes.

Table C-7 Operating Environment Temperature

material		temperature range
outer cylinder	retainer	
steel	steel	-20°C~110°C
	resin	-20°C~ 80°C
stainless	steel	-20°C~140°C*
	resin	-20°C~ 80°C

* If a seal is used in the stainless steel slide bush, the temperature is up to 120°C . Please contact NB if a temperature range exceeds 140°C .

Figure C-3 Seal Profile

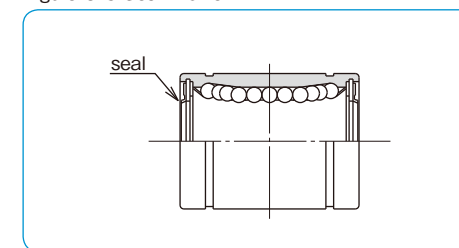

LIFE CALCULATION

Since ball elements are used as the rolling element in the NB slide bush, the following equation is used to calculate the travel life.

$$L = \left(\frac{f_H \cdot f_T \cdot f_C \cdot C}{f_W \cdot P} \right)^3 \cdot 50$$

L: rated life (km) f_H: hardness coefficient
 f_T: temperature coefficient f_C: contact coefficient
 f_W: applied load coefficient C: basic dynamic load rating (N)
 P: applied load (N)
 *Refer to page Eng-5 for the coefficients.

If the stroke distance and number of strokes per unit time are constant, the life time is calculated using the following equation.

$$L_h = \frac{L \cdot 10^3}{2 \cdot l_s \cdot n_i \cdot 60}$$

L_h: life time (hr) l_s: stroke length (m)
 L: rated life (km) n_i: number of cycles per minute (cpm)

LOAD RATING FOR OPEN TYPE SLIDE BUSH

For the open type slide bush an opening is provided to allow the shaft to be supported from underneath. In case a load is constantly applied in the direction of the opening (for example, being used with a vertical shaft or an overhang loading is applied), the load rating decreases due to less number of loaded rows of ball elements. (Table C-8) Therefore, the load rating must be calibrated at the time of design based on the direction of the loading.

Table C-8 Direction of Load and Basic Static Load Rating

part number	SM10G~16G-OP KB10G~16G-OP SW 8G~10G-OP SME (D) 10G~16G CE (D) 16	SM20 (G) -OP KB20 (G) -OP SW12 (G) -OP SME (D) 20 CE (D) 20	SM25 (G) ~100-OP KB25 (G) ~80-OP SW16 (G) ~64-OP SME (D) 25~30 CE (D) 25~30	SM120,150-OP
loading from above				
	C	C	C	C
loading from below				
	0.64C	0.54C	0.57C	0.35C

※ Excluding all the 3-row steel retainer types. Please contact NB in case of 3-row steel retainer.

MOUNTING

Examples of Mounting methods are shown in Figures C-4 ~7.

Figure C-4 Standard Type

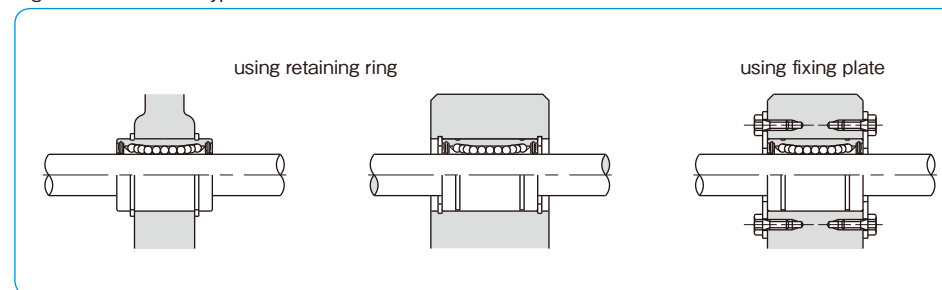

Figure C-5 Clearance Adjustable Type

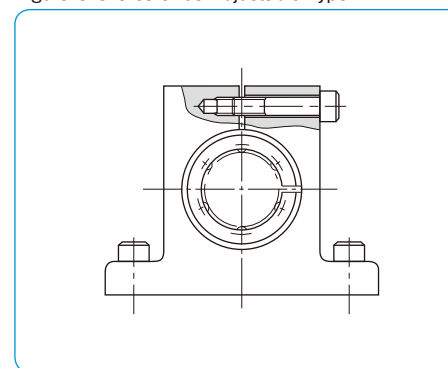

Figure C-6 Open Type

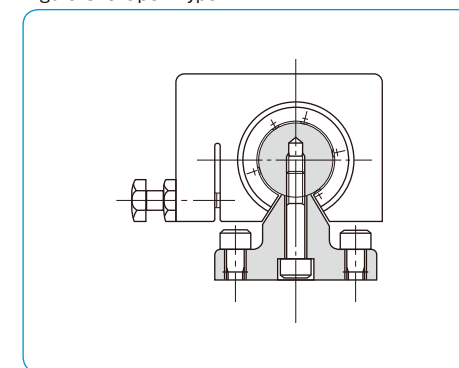
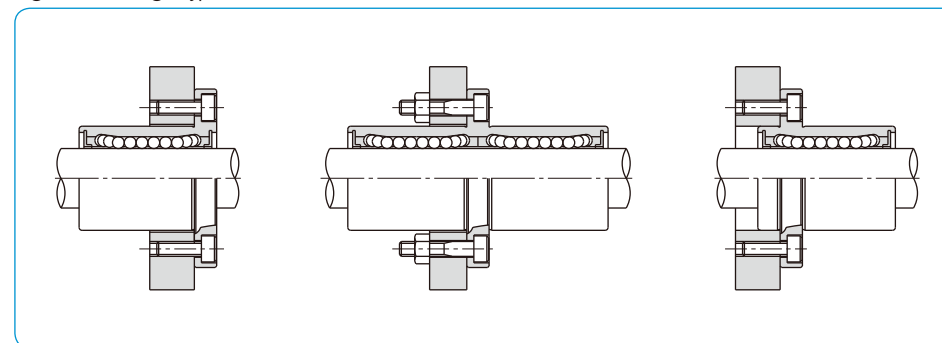

Figure C-7 Flange Type



Fit

The normal clearance fit listed in Table C-9 is generally selected as a shaft outer diameter tolerance for the NB slide bush. The transition fit is selected for a higher accuracy by reducing clearance between slide bush and shaft. Matching bush and shaft (FIT series) is also available for customer's specified clearance. Please be cautious not to apply excess preloading with clearance adjustable and open types. Please keep preloading within the maximum radial clearance listed in the dimension table. The flange-type bush is generally inserted into an installation bore, which is slightly larger than the outer cylinder. However, if the outer cylinder is used as the pilot, H7 tolerance is recommended for housing.

The recommended clearances for the flange type are listed in Table C-10.

Table C-9 Recommended Fit

series	accuracy grade	shaft		housing	
		clearance fit	transition fit	clearance fit	transition fit
SM	high	g6	h6	H7	J7
	precision(P)	g5	h5	H6	J6
SM-G-L	high	g6	—	H7	—
SM-W	high	g6	—	H7	—
KB	high	h6	j6	H7	J7
KB-W	high	h6	—	H7	—
SW	high	g6	h6	H7	J7
	precision(P)	g5	h5	H6	J6
SW-W	high	g6	—	H7	—
GM	high	g6	h6	H7	—
GM-W	high	g6	—	H7	—

Table C-10 Recommended Fit (Flange Type)

series	shaft	
	clearance fit	transition fit
SMF	g6	h6
SMK-G-L	g6	—
SMF-W	g6	—
TRF	g6	—
KBF	h6	j6
KBF-W	h6	—
SWF	g6	h6
SWF-W	g6	—

Notes on Shaft Selection:

In order to ensure a high accuracy motion of the bush, it is essential to select a high quality shaft. In selecting a shaft, please take note of: Hardness: 58HRC or more (refer to hardness coefficient on page Eng-5) recommended Surface Roughness: less than 0.4Ra recommended

Notes on Installation

When inserting a slide bush into a housing, carefully insert it by using a jig to apply a uniform pushing force at the end of the outer cylinder, as illustrated in Figure C-8. Motion performance may be diminished if an excessive force is applied to the resin portion of the outer cylinder, the side-ring, or the seal.

Ensure that all burrs are removed from the shaft and carefully install the bush by aligning it with the center of the bore. Excessive force may drop out the ball elements during insertion.

When two or more shafts are used, the parallelism of the shafts will greatly affect the motion characteristics and life of the slide bush. Please check the parallelism by moving the slide bush back and forth the length of stroke to check for freedom of movement before final fixing of the shaft. Please refer to page F-3 for shaft specifications.

GM Standard Type

Please avoid a tension load when retaining rings are used for installation.

Figure C-8 Insertion of Slide Bush

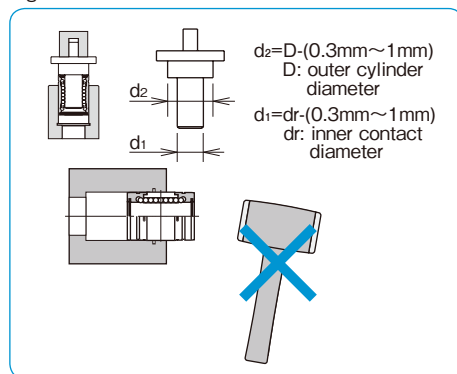
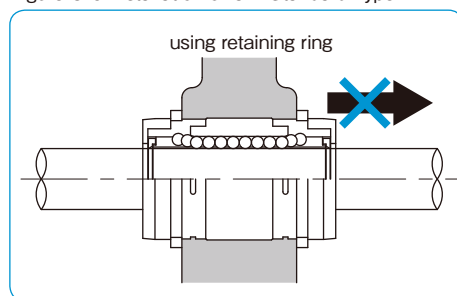

Figure C-9 Installation of GM Standard Type



LUBRICATION

It is important to lubricate the slide bush for an accurate operation and for a long life. Anti-rust oil is applied to NB slide bush prior to shipment. The NB selected anti-rust oil has a little effect on the lubricant, however, please apply lubricant after cleaning the slide bush by, for example, kerosene, etc.

Grease Lubricant

Prior to usage, please apply grease, then re-lubricate periodically according to the operating conditions. (Lithium soap-based grease is recommended.) Re-lubrication can be done by directly applying grease inside the ball bush or by using a grease fitting as Figure C-10 shows.

A special low dust generating grease is optional for clean room application, please refer to page Eng-39.

Oil Lubricant

Prior to usage, please apply oil directly to the shaft surface or by using an oil hole as Figure C-11 shows. Turbine oil (ISO standard VG32-68) is recommended.

Oil holes can be machined (see Figure C-11) in the center portion of the outer cylinder. Please contact NB for oil hole specification.

Figure C-10 Grease Fitting

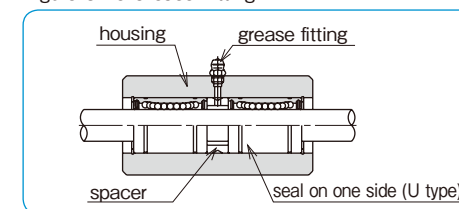
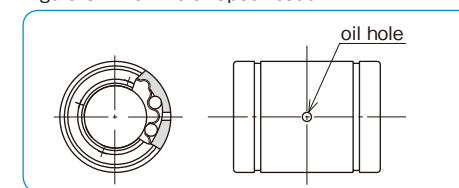

Figure C-11 Oil Hole - Specification-



DUST PREVENTION

A smooth ball circulation is hindered by dust or foreign particles inside the slide bush. Seals on both sides is a standard option for the NB slide bush, however, in a harsh environment it is necessary to attach bellows or protective covers.

Figure C-12 Example of Dust Prevention

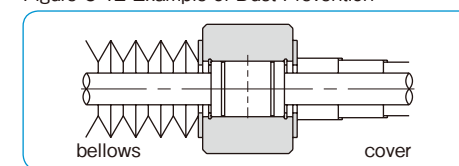

NOTES ON HANDLING

The NB slide bush is a precision component, please handle with care to maintain its high motion accuracy.

The slide bush is designed for linear motion, so that for applications in which a combination of linear and rotational motion is a requirement, let us recommend Stroke Bush, Slide Rotary Bush, or Rotary Ball Spline.

Figure C-13 Direction of Motion

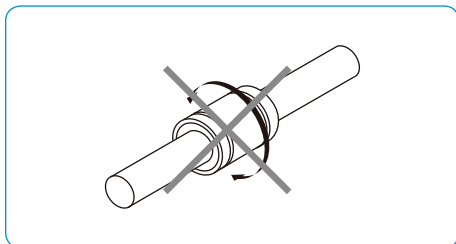

OTHER SPECIFICATIONS

● Flange Type Slide Bush with Surface-Treatment

The following surface treatments are available as standard option:

SK	electroless nickel plating
LF	low temperature black chrome treatment with fluoride coating
SB	black oxide (excluding anti-corrosion type)
SC	industrial chrome plating

* Please contact NB for the thickness of coating and the resulting outer diameter tolerance.

● Special Specifications

Please contact NB for more information on surface treatment, oil hole (Figure C-11), flange mounting hole (Figure C-14), etc.

Figure C-14 Examples of Special Installation Hole

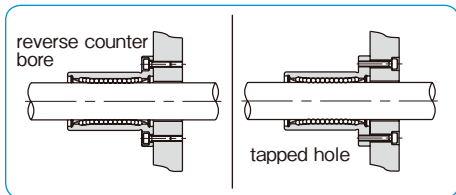

FELT SEAL

A felt seal FLM strengthens lubrication characteristics and extends re-lubrication period of the NB slide bush.

Figure C-15 Felt Seal

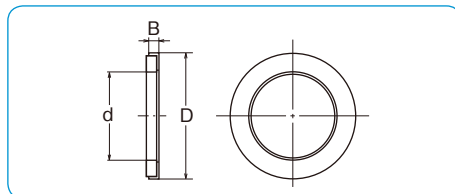

part number	major dimensions(mm)			applicable slide bush
	d	D	B	
FLM 6	6	12	2	SM 6 / GM 6
FLM 8	8	15	2	SM 8 / GM 8
FLM 10	10	19	3	SM 10 / GM10
FLM 12	12	21	3	SM 12 / GM12
FLM 13	13	23	3	SM 13 / GM13
FLM 16	16	28	4	SM 16 / GM16
FLM 20	20	32	4	SM 20 / GM20
FLM 25	25	40	5	SM 25 / GM25
FLM 30	30	45	5	SM 30 / GM30
FLM 35	35	52	5	SM 35
FLM 40	40	60	5	SM 40
FLM 50	50	80	10	SM 50
FLM 60	60	90	10	SM 60
FLM 80	80	120	10	SM 80
FLM100	100	150	10	SM100

Felt Seal Installation

The felt seal does not work as a retaining ring. Figure C-16 shows how to install the felt seal.

Figure C-16 Example of Felt Seal Installation

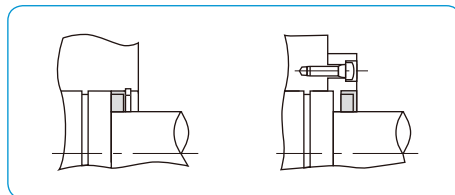

ACCURACY

The accuracy of CE/CD-type support rails are measured as shown in Figure C-17.

Figure C-17 Accuracy Measurement

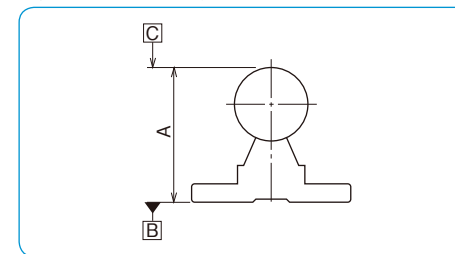
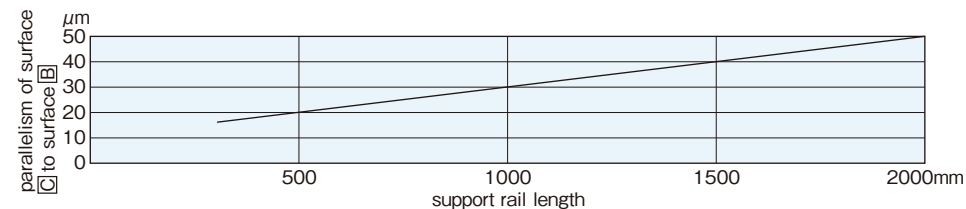

Figure C-18 Accuracy of CE/CD-type Support Rails



NOTES ON USAGE OF BLOCK SERIES

Reference Surface

The NB slide units have a reference surface as shown in Figure C-19. Accuracy is achieved by simply pushing the reference surface against the shoulder of the installation surface. (Excluding RBW and SMP types)

Figure C-19 Reference Surface

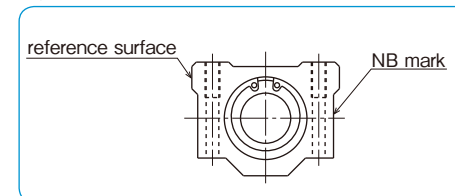

Clearance Adjustment

On the clearance adjustment type please avoid excessive preloading. In the same manner please do not apply excessive torque when tightening the screws.

Table C-11 Recommended Torque for RBW Type

part number	mounting screw	torque N · m
RBW8	#6	1.3
RBW10,12	#8	1.9
RBW16	#10	5.2

Mounting of RBW Type

RBW type has a resin housing. Table C-11 shows proper torque values.

Figure C-20 Special Installation of SMJ Type

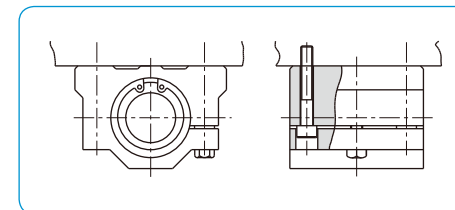

Recommended Fit

For clearance fit please use a shaft with g6 tolerance and for transition fit a shaft with h6 tolerance. (Excluding adjustable-clearance and open types)

Special Installation Case of SMJ Type

Special mouting holes will be required for installations such as Figure C-20 shows. Please contact NB for special requirements.

SM TYPE

— Standard Type —

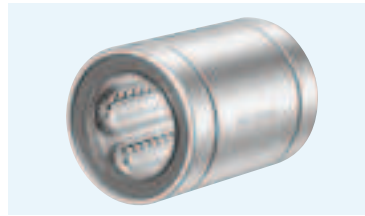

part number structure

example **SMS25G UU-P**

specification
SM: standard
SMS: anti-corrosion

inner contact diameter (dr)

retainer material
blank: standard/steel
 anti-corrosion/stainless steel
G: resin

accuracy grade
blank: high
P: precision

seal
blank: without seal
U: seal on one side
UU: seals on both sides

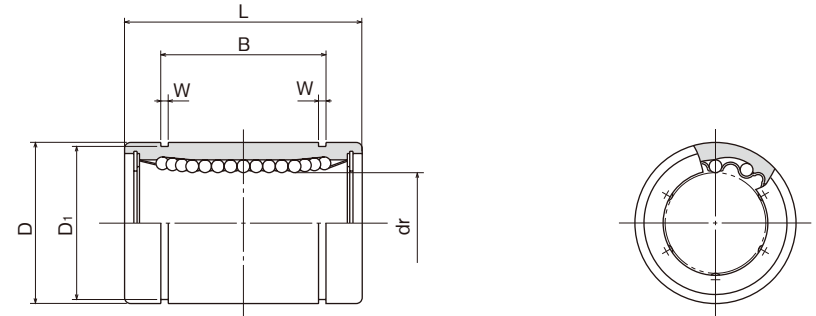

part number				number of ball circuits	major dimensions			
standard		anti-corrosion			dr		D	
steel retainer	resin retainer	stainless retainer	resin retainer		mm	tolerance μm	mm	tolerance μm
SM 3	SM 3G	SMS 3	SMS 3G	4	3	7	0	
SM 4	SM 4G	SMS 4	SMS 4G	4	4	8	0	
SM 5	SM 5G	SMS 5	SMS 5G	4	5	10	-9	
SM 6	SM 6G	SMS 6	SMS 6G	4	6	12	0	
SM 8s	SM 8sG	SMS 8s	SMS 8sG	4	8	15	-11	
SM 8	SM 8G	SMS 8	SMS 8G	4	8	15	0	
SM 10	SM10G	SMS10	SMS10G	4	10	19	0	
SM 12	SM12G	SMS12	SMS12G	4	12	21	0	
SM 13	SM13G	SMS13	SMS13G	4	13	23	-13	
SM 16	SM16G	SMS16	SMS16G	4	16	28	0	
SM 20	SM20G	SMS20	SMS20G	5	20	32	0	
SM 25	SM25G	SMS25	SMS25G	6	25	40	-16	
SM 30	SM30G	SMS30	SMS30G	6	30	45	0	
SM 35	SM35G	SMS35	SMS35G	6	35	52	0	
SM 40	SM40G	SMS40	SMS40G	6	40	60	0	
SM 50	SM50G	SMS50	SMS50G	6	50	80	-19	
SM 60	SM60G	SMS60	SMS60G	6	60	90	0	
SM 80	SM80G	SMS80	SMS80G	6	80	120	-22	
SM100	—	—	—	6	100	150	0	
SM120	—	—	—	8	120	180	-25	
SM150	—	—	—	8	150	210	-29	

mm	L tolerance mm	mm	B tolerance mm	mm	W mm	mm	D ₁ mm	eccentricity		radial clearance (maximum) μm	basic load rating		mass g	shaft diameter mm
								precision μm	high μm		C N	static Co N		
10	—	—	—	—	—	—	—	—	—	69	105	1.4	3	
12	0	—	—	—	—	—	—	4	8	88	127	2.0	4	
15	-0.12	10.2	—	—	1.1	9.6	—	—	—	167	206	4.0	5	
19	—	13.5	—	—	1.1	11.5	—	—	—	206	265	8.5	6	
17	—	11.5	—	—	1.1	14.3	—	—	—	176	216	11	8	
24	—	17.5	—	—	1.1	14.3	—	—	—	274	392	17	8	
29	0	22	0	—	1.3	18	—	8	12	372	549	36	10	
30	-0.2	23	-0.2	—	1.3	20	—	—	—	510	784	42	12	
32	—	23	—	—	1.3	22	—	—	—	510	784	49	13	
37	—	26.5	—	—	1.6	27	—	—	—	774	1,180	76	16	
42	—	30.5	—	—	1.6	30.5	—	—	—	882	1,370	100	20	
59	—	41	—	—	1.85	38	—	10	15	980	1,570	240	25	
64	—	44.5	—	—	1.85	43	—	—	—	1,570	2,740	270	30	
70	0	49.5	0	—	2.1	49	—	—	—	1,670	3,140	425	35	
80	-0.3	60.5	-0.3	—	2.1	57	—	12	20	2,160	4,020	654	40	
100	—	74	—	—	2.6	76.5	—	—	—	3,820	7,940	1,700	50	
110	—	85	—	—	3.15	86.5	—	—	—	4,700	10,000	2,000	60	
140	—	105.5	—	—	4.15	116	—	17	25	7,350	16,000	4,520	80	
175	0	125.5	0	—	4.15	145	—	—	—	14,100	34,800	8,600	100	
200	-0.4	158.6	-0.4	—	4.15	175	—	20	30	16,400	40,000	15,000	120	
240	—	170.6	—	—	5.15	204	—	25	40	21,100	54,300	20,250	150	

1N=0.102kgf

SM-AJ TYPE

– Clearance Adjustable Type –

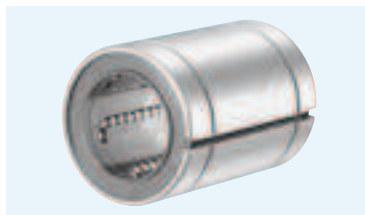

part number structure

example **SMS25G UU-AJ**

specification
SM: standard
SMS: anti-corrosion

inner contact diameter (dr)

retainer material
blank: standard/steel
 anti-corrosion/stainless steel
G: resin

clearance-adjustable

seal
blank: without seal
U: seal on one side
UU: seals on both sides

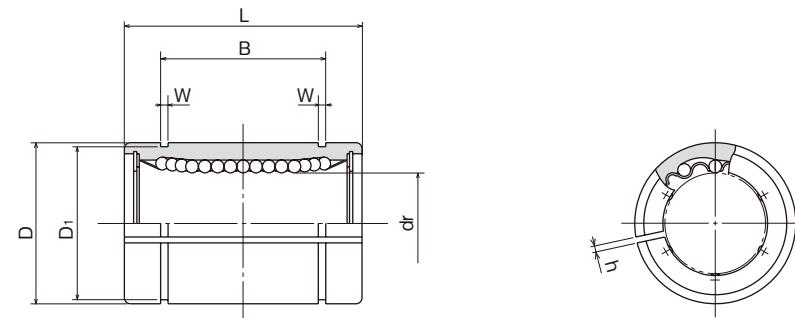

part number				number of ball circuits	dr	major dimensions		
standard steel retainer	anti-corrosion resin retainer	stainless steel retainer	resin retainer			mm	tolerance* μm	D mm
—	SM 6G-AJ	—	SMS 6G-AJ	4	6	0	12	0
—	SM 8sG-AJ	—	SMS 8sG-AJ	4	8		15	-11
—	SM 8G-AJ	—	SMS 8G-AJ	4	8		15	
—	SM10G-AJ	—	SMS10G-AJ	4	10		19	
SM 12-AJ	SM12G-AJ	SMS12-AJ	SMS12G-AJ	4	12	-9	21	0
SM 13-AJ	SM13G-AJ	SMS13-AJ	SMS13G-AJ	4	13		23	-13
SM 16-AJ	SM16G-AJ	SMS16-AJ	SMS16G-AJ	4	16		28	
SM 20-AJ	SM20G-AJ	SMS20-AJ	SMS20G-AJ	5	20		32	0
SM 25-AJ	SM25G-AJ	SMS25-AJ	SMS25G-AJ	6	25	0	40	0
SM 30-AJ	SM30G-AJ	SMS30-AJ	SMS30G-AJ	6	30	-10	45	-16
SM 35-AJ	SM35G-AJ	SMS35-AJ	SMS35G-AJ	6	35		52	
SM 40-AJ	SM40G-AJ	SMS40-AJ	SMS40G-AJ	6	40	0	60	0
SM 50-AJ	SM50G-AJ	SMS50-AJ	SMS50G-AJ	6	50	-12	80	-19
SM 60-AJ	SM60G-AJ	SMS60-AJ	SMS60G-AJ	6	60	0	90	0
SM 80-AJ	SM80G-AJ	—	—	6	80	-15	120	-22
SM100-AJ	—	—	—	6	100	0	150	0
SM120-AJ	—	—	—	8	120	-20	180	-25
SM150-AJ	—	—	—	8	150	0/-25	210	0/-29

* Accuracy is measured prior to machining clearance slit.

mm	L tolerance mm	B tolerance mm		W mm	D ₁ mm	h mm	eccentricity* μm	basic load rating		mass g	shaft diameter mm	
		mm	mm					dynamic C N	static Co N			
19	0	13.5	0	1.1	11.5	1	12	206	265	7.5	6	
17		11.5		1.1	14.3	1		176	216	10	8	
24		17.5		1.1	14.3	1		274	392	14.7	8	
29		22		1.3	18	1		372	549	29	10	
30		-0.2		23	1.3	20		1.5	510	784	41	12
32				23	1.3	22		1.5	510	784	48	13
37	-0.3	26.5	-0.3	1.6	27	1.5	15	774	1,180	75	16	
42		30.5		1.6	30.5	1.5		882	1,370	98	20	
59				41	1.85	38		2	980	1,570	237	25
64				44.5	1.85	43		2.5	1,570	2,740	262	30
70		0		49.5	2.1	49		2.5	1,670	3,140	420	35
80				60.5	2.1	57		3	2,160	4,020	640	40
100	-0.4	74	-0.4	2.6	76.5	3	20	3,820	7,940	1,680	50	
110		85		3.15	86.5	3		4,700	10,000	1,980	60	
140				105.5	4.15	116		3	7,350	16,000	4,400	80
175		0		125.5	4.15	145		3	14,100	34,800	8,540	100
200				158.6	4.15	175		3	16,400	40,000	14,900	120
240				170.6	5.15	204		3	21,100	54,300	20,150	150

1N=0.102kgf

SM-OP TYPE

– Open Type –

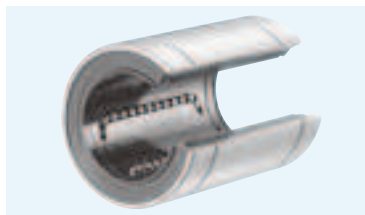

part number structure

example **SMS25G UU-OP**

specification
SM: standard
SMS: anti-corrosion

inner contact diameter (dr)

retainer material
blank: standard/steel
 anti-corrosion/stainless steel
G: resin

open type

seal
blank: without seal
U: seal on one side
UU: seals on both sides

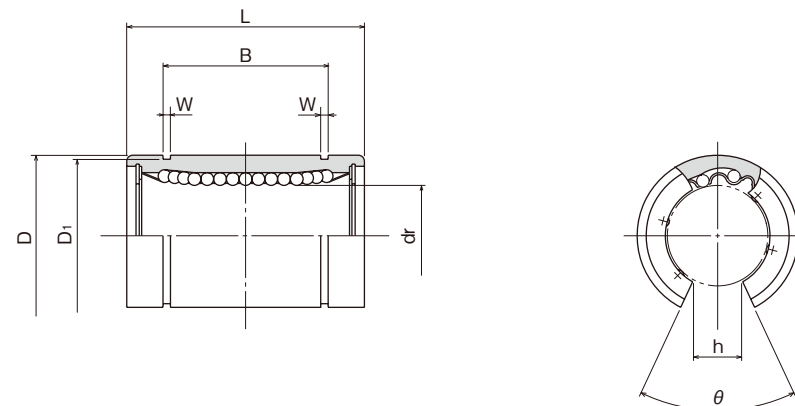

part number				number of ball circuits	dr mm	dr tolerance* μm	major dimensions	
standard steel retainer	resin retainer	anti-corrosion stainless retainer	resin retainer				D mm	D tolerance* μm
–	SM10G-OP	–	SMS10G-OP	3	10		19	
SM 12-OP	SM12G-OP	SMS12-OP	SMS12G-OP	3	12	0	21	0
SM 13-OP	SM13G-OP	SMS13-OP	SMS13G-OP	3	13	– 9	23	–13
SM 16-OP	SM16G-OP	SMS16-OP	SMS16G-OP	3	16		28	
SM 20-OP	SM20G-OP	SMS20-OP	SMS20G-OP	4	20	0	32	0
SM 25-OP	SM25G-OP	SMS25-OP	SMS25G-OP	5	25	–10	40	–16
SM 30-OP	SM30G-OP	SMS30-OP	SMS30G-OP	5	30		45	
SM 35-OP	SM35G-OP	SMS35-OP	SMS35G-OP	5	35	0	52	0
SM 40-OP	SM40G-OP	SMS40-OP	SMS40G-OP	5	40	–12	60	–19
SM 50-OP	SM50G-OP	SMS50-OP	SMS50G-OP	5	50	0	80	0
SM 60-OP	SM60G-OP	SMS60-OP	SMS60G-OP	5	60	–15	90	–22
SM 80-OP	SM80G-OP	–	–	5	80	0	120	0
SM100-OP	–	–	–	5	100	–20	150	–25
SM120-OP	–	–	–	6	120		180	
SM150-OP	–	–	–	6	150	0/–25	210	0/–29

* Accuracy is measured prior to machining open slit.

mm	L tolerance mm	B		W mm	D ₁ mm	h mm	θ	eccentricity* μm	basic load rating		mass g	shaft diameter mm
		mm	tolerance mm						C N	Co N		
29	0 –0.2	22	0 –0.2	1.3	18	6.8	80°	12	372	549	23	10
30		23		1.3	20	8	80°		510	784	32	12
32		23		1.3	22	9	80°		510	784	37	13
37		26.5		1.6	27	11	80°		774	1,180	58	16
42		30.5		1.6	30.5	11	60°		882	1,370	79	20
59	0 –0.3	41	0 –0.3	1.85	38	12	50°	15	980	1,570	203	25
64		44.5		1.85	43	15	50°		1,570	2,740	228	30
70		49.5		2.1	49	17	50°		1,670	3,140	355	35
80		60.5		2.1	57	20	50°		2,160	4,020	546	40
100		74		2.6	76.5	25	50°		3,820	7,940	1,420	50
110	0 –0.4	85	0 –0.4	3.15	86.5	30	50°	20	4,700	10,000	1,650	60
140		105.5		4.15	116	40	50°		7,350	16,000	3,750	80
175		125.5		4.15	145	50	50°		14,100	34,800	7,200	100
200		158.6		4.15	175	85	80°		16,400	40,000	11,600	120
240		170.6		5.15	204	105	80°		21,100	54,300	15,700	150

1N=0.102kgf

SM-G-L TYPE

– Long Type –



part number structure

example **SM25G-LUU**

SM type

inner contact diameter (dr)

seals on both sides

long type

resin retainer

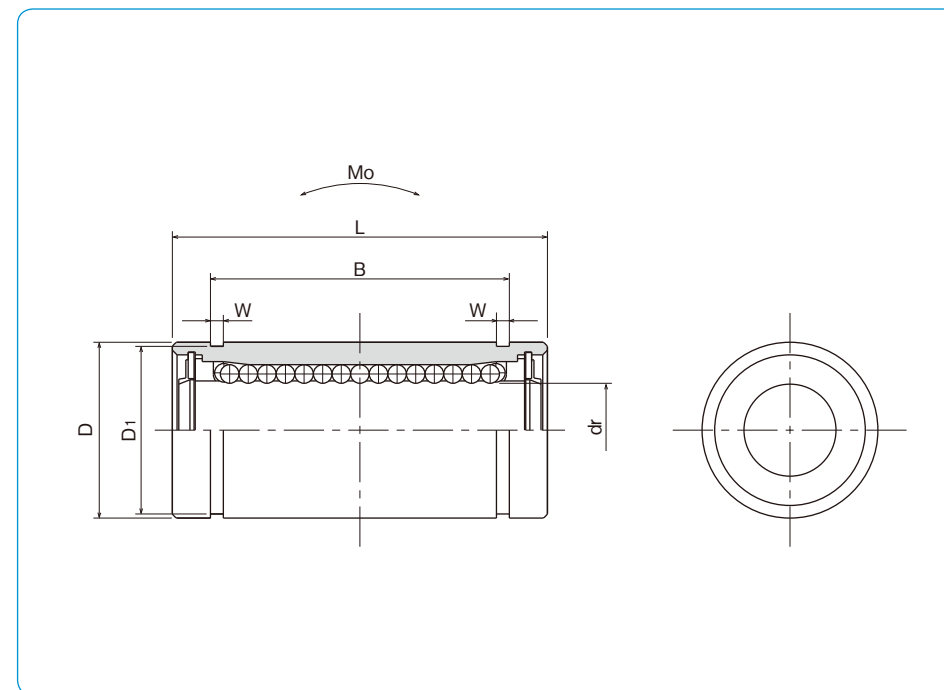

part number*	number of ball circuits	dr		D		major dimensions			B	tolerance mm
		mm	tolerance μm	mm	tolerance μm	L	tolerance mm	mm		
SM 6G-LUU	4	6	0	12	0	26	0	20.5	-0.2	
SM 8G-LUU	4	8		15	-13	32		25.5		
SM10G-LUU	4	10		19	39	32				
SM12G-LUU	4	12		21	0	41		34		
SM13G-LUU	4	13		23	-16	45		36		
SM16G-LUU	4	16		28	53	42		42		
SM20G-LUU	5	20		32	59	47.5		47.5		
SM25G-LUU	6	25		40	0	83		69		0
SM30G-LUU	6	30		45	-19	90		75		-0.3

*UU type is standard.

W	D ₁	eccentricity	basic load rating		allowable static moment	mass	shaft diameter
			dynamic C	static Co			
mm	mm	μm	N	N	$\text{N} \cdot \text{m}$	g	mm
1.1	11.5	15	262	476	1.15	10	6
1.1	14.3		352	615	1.94	19	8
1.3	18		493	1,005	3.98	38	10
1.3	20		637	1,430	6.26	43	12
1.3	22		682	1,560	7.68	62	13
1.6	27		1,039	2,350	13.2	99	16
1.6	30.5	20	1,160	2,740	17.9	125	20
1.85	38		1,300	2,960	27.2	315	25
1.85	43		2,160	5,880	61.3	347	30

1N \approx 0.102kgf 1N \cdot m \approx 0.102kgf \cdot m

SM-W TYPE

– Double-Wide Type –

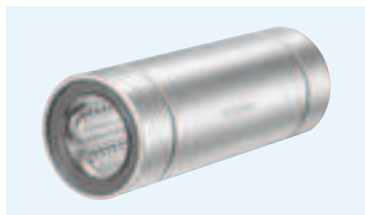

part number structure

example **SMS25GWUU**

specification
SM: standard
SMS: anti-corrosion

inner contact diameter (dr)

retainer material
blank: standard/steel
 anti-corrosion/stainless steel
G: resin

seal
blank: without seal
UU: seals on both sides

double-wide type

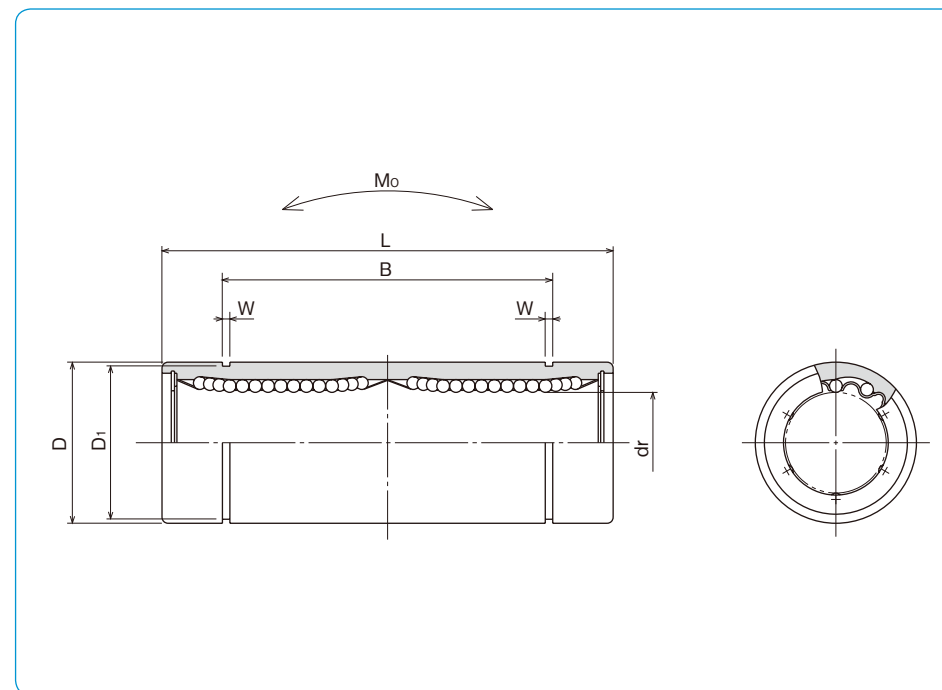

part number				number of ball circuits	dr		major dimensions	
standard steel retainer	resin retainer	anti-corrosion stainless retainer	resin retainer		mm	tolerance μm	mm	tolerance μm
SM 3W	SM 3GW	SMS 3W	SMS 3GW	4	3	0 -10	7	0
SM 4W	SM 4GW	SMS 4W	SMS 4GW	4	4		8	-11
SM 5W	SM 5GW	SMS 5W	SMS 5GW	4	5		10	0
SM 6W	SM 6GW	SMS 6W	SMS 6GW	4	6		12	-13
SM 8W	SM 8GW	SMS 8W	SMS 8GW	4	8		15	0
SM10W	SM10GW	SMS10W	SMS10GW	4	10		19	-16
SM12W	SM12GW	SMS12W	SMS12GW	4	12		21	0
SM13W	SM13GW	SMS13W	SMS13GW	4	13		23	-19
SM16W	SM16GW	SMS16W	SMS16GW	4	16		28	0
SM20W	SM20GW	SMS20W	SMS20GW	5	20		32	-22
SM25W	SM25GW	SMS25W	SMS25GW	6	25	0 -12	40	0
SM30W	SM30GW	SMS30W	SMS30GW	6	30		45	-19
SM35W	SM35GW	SMS35W	SMS35GW	6	35		52	0
SM40W	SM40GW	SMS40W	SMS40GW	6	40		60	-22
SM50W	SM50GW	SMS50W	SMS50GW	6	50		80	0
SM60W	SM60GW	SMS60W	SMS60GW	6	60		0/-20	90

mm	L tolerance mm	B tolerance mm		W mm	D ₁ mm	eccentricity μm	basic load rating		allowable static moment Mo N·m	mass g	shaft diameter mm
		mm	mm				dynamic C N	static Co N			
19	0 -0.3	—	—	—	—	10	138	210	0.51	3.2	3
23		—	—	—	—		176	254	0.63	4.8	4
28		20.4	0 -0.3	1.1	9.6		265	412	1.38	11	5
35		27		1.1	11.5		323	530	2.18	16	6
45		35		1.1	14.3	431	784	4.31	31	8	
55		44		1.3	18	588	1,100	7.24	62	10	
57		46		1.3	20	813	1,570	10.9	80	12	
61		46		1.3	22	813	1,570	11.6	90	13	
70		53	1.6	27	1,230	2,350	19.7	145	16		
80		61	1.6	30.5	1,400	2,740	26.8	180	20		
112	82	0 -0.4	0 -0.4	1.85	38	20	1,560	3,140	43.4	440	25
123	89			1.85	43		2,490	5,490	82.8	480	30
135	99			2.1	49	25	2,650	6,270	110	795	35
151	121			2.1	57		3,430	8,040	147	1,170	40
192	148			2.6	76.5		6,080	15,900	397	3,100	50
209	170			3.15	86.5		7,550	20,000	530	3,500	60

1N=0.102kgf 1N·m=0.102kgf·m

SMF TYPE

– Round Flange Type –

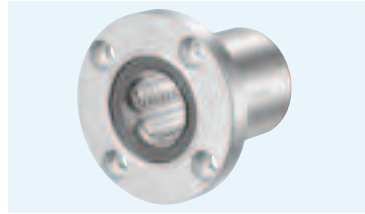

part number structure

example **SMSF 25 G UU-SK**

specification
SMF: standard
SMSF: anti-corrosion

inner contact diameter (dr)

retainer material
blank: standard/steel
 anti-corrosion/stainless steel
G: resin

outer cylinder
 surface treatment
blank: no surface treatment
SK: electroless nickel plating
LF: low temperature black chrome
 treatment with fluoride coating
SB: black oxide (not available on
 anti-corrosion type)
SC: industrial chrome plating

seal
blank: without seal
UU: seals on both sides

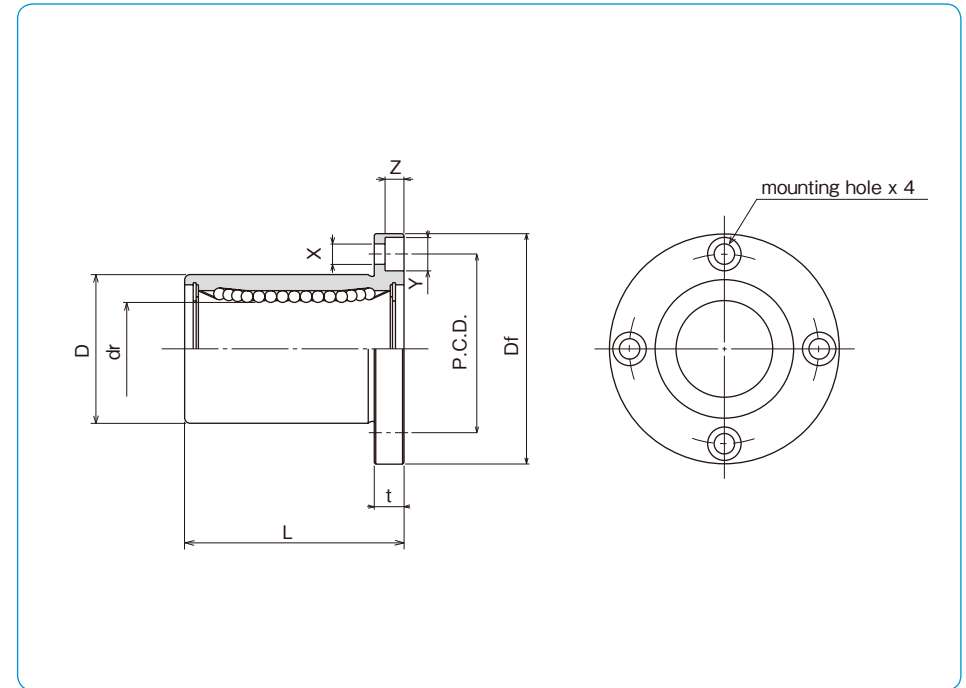

part number				number of ball circuits	major dimensions			
standard steel retainer	anti-corrosion resin retainer	stainless steel retainer	resin retainer		dr	D	L	
				mm	tolerance μm	mm	tolerance μm	± 0.3 mm
SMF 6	SMF 6G	SMSF 6	SMSF 6G	4	6	12	0	19
SMF 8s	SMF 8sG	SMSF 8s	SMSF 8sG	4	8	15	-13	17
SMF 8	SMF 8G	SMSF 8	SMSF 8G	4	8	15	0	24
SMF 10	SMF10G	SMSF10	SMSF10G	4	10	19	-16	29
SMF 12	SMF12G	SMSF12	SMSF12G	4	12	21	0	30
SMF 13	SMF13G	SMSF13	SMSF13G	4	13	23	-19	32
SMF 16	SMF16G	SMSF16	SMSF16G	4	16	28	0	37
SMF 20	SMF20G	SMSF20	SMSF20G	5	20	32	-22	42
SMF 25	SMF25G	SMSF25	SMSF25G	6	25	40	0	59
SMF 30	SMF30G	SMSF30	SMSF30G	6	30	45	-19	64
SMF 35	SMF35G	SMSF35	SMSF35G	6	35	52	0	70
SMF 40	SMF40G	SMSF40	SMSF40G	6	40	60	-22	80
SMF 50	SMF50G	SMSF50	SMSF50G	6	50	80	0	100
SMF 60	SMF60G	SMSF60	SMSF60G	6	60	90	0	110
SMF 80	-	-	-	6	80	120	-25	140
SMF100	-	-	-	6	100	150	0/-20	175

Df	t	flange P.C.D.	X×Y×Z	eccentricity	perpendicularity	basic load rating		mass	shaft diameter
						dynamic C	static Co		
mm	mm	mm	mm	μm	μm	N	N	g	mm
28	5	20	3.5×6×3.1	12	12	206	265	24	6
32	5	24	3.5×6×3.1			176	216	32	8
32	5	24	3.5×6×3.1			274	392	37	8
40	6	29	4.5×7.5×4.1			372	549	72	10
42	6	32	4.5×7.5×4.1			510	784	76	12
43	6	33	4.5×7.5×4.1			510	784	88	13
48	6	38	4.5×7.5×4.1	15	15	774	1,180	120	16
54	8	43	5.5×9×5.1			882	1,370	180	20
62	8	51	5.5×9×5.1			980	1,570	340	25
74	10	60	6.6×11×6.1			1,570	2,740	470	30
82	10	67	6.6×11×6.1			1,670	3,140	650	35
96	13	78	9×14×8.1			2,160	4,020	1,060	40
116	13	98	9×14×8.1	20	20	3,820	7,940	2,200	50
134	18	112	11×17×11.1			4,700	10,000	3,000	60
164	18	142	11×17×11.1			7,350	16,000	5,800	80
200	20	175	14×20×13.1			14,100	34,800	10,600	100

1N=0.102kgf

SMK TYPE

– Square Flange Type –

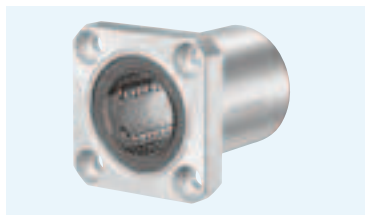

part number structure

example **SMSK 25 G UU-SK**

specification
SMK: standard
SMSK: anti-corrosion

inner contact diameter (dr)

retainer material
blank: standard/steel
 anti-corrosion/stainless steel
G: resin

outer cylinder surface treatment
blank: no surface treatment
SK: electroless nickel plating
LF: low temperature black chrome treatment with fluoride coating
SB: black oxide (not available on anti-corrosion type)
SC: industrial chrome plating

seal
blank: without seal
UU: seals on both sides

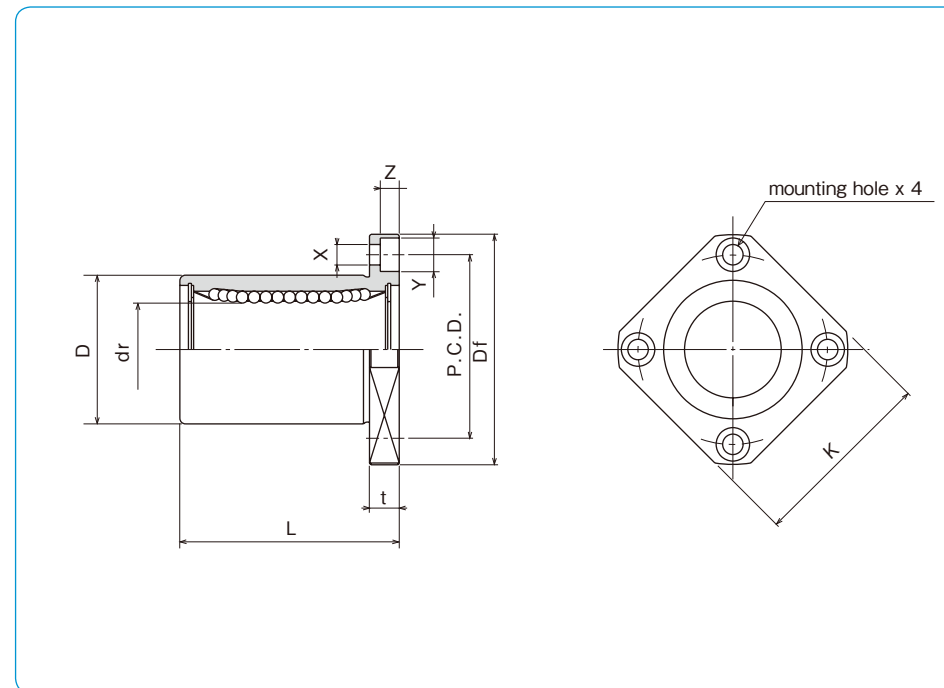

part number				number of ball circuits	major dimensions		
standard steel retainer	anti-corrosion resin retainer	stainless steel retainer	resin retainer		dr mm	D mm	L mm
SMK 6	SMK 6G	SMSK 6	SMSK 6G	4	6	12	19
SMK 8s	SMK 8sG	SMSK 8s	SMSK 8sG	4	8	15	17
SMK 8	SMK 8G	SMSK 8	SMSK 8G	4	8	15	24
SMK 10	SMK 10G	SMSK 10	SMSK 10G	4	10	19	29
SMK 12	SMK 12G	SMSK 12	SMSK 12G	4	12	21	30
SMK 13	SMK 13G	SMSK 13	SMSK 13G	4	13	23	32
SMK 16	SMK 16G	SMSK 16	SMSK 16G	4	16	28	37
SMK 20	SMK 20G	SMSK 20	SMSK 20G	5	20	32	42
SMK 25	SMK 25G	SMSK 25	SMSK 25G	6	25	40	59
SMK 30	SMK 30G	SMSK 30	SMSK 30G	6	30	45	64
SMK 35	SMK 35G	SMSK 35	SMSK 35G	6	35	52	70
SMK 40	SMK 40G	SMSK 40	SMSK 40G	6	40	60	80
SMK 50	SMK 50G	SMSK 50	SMSK 50G	6	50	80	100
SMK 60	SMK 60G	SMSK 60	SMSK 60G	6	60	90	110
SMK 80	—	—	—	6	80	120	140
SMK 100	—	—	—	6	100	150	175

Df mm	flange				eccentricity μm	perpendicularity μm	basic load rating		mass g	shaft diameter mm		
	K mm	t mm	P.C.D. mm	X×Y×Z mm			dynamic C N	static Co N				
28	22	5	20	3.5×6×3.1	12	12	206	265	18	6		
32	25	5	24	3.5×6×3.1			176	216	24	8		
32	25	5	24	3.5×6×3.1			274	392	29	8		
40	30	6	29	4.5×7.5×4.1			372	549	52	10		
42	32	6	32	4.5×7.5×4.1			510	784	57	12		
43	34	6	33	4.5×7.5×4.1			510	784	72	13		
48	37	6	38	4.5×7.5×4.1	15	15	774	1,180	104	16		
54	42	8	43	5.5×9×5.1			882	1,370	145	20		
62	50	8	51	5.5×9×5.1			980	1,570	300	25		
74	58	10	60	6.6×11×6.1			1,570	2,740	375	30		
82	64	10	67	6.6×11×6.1			1,670	3,140	560	35		
96	75	13	78	9×14×8.1			20	20	2,160	4,020	880	40
116	92	13	98	9×14×8.1	3,820	7,940			2,000	50		
134	106	18	112	11×17×11.1	4,700	10,000			2,560	60		
164	136	18	142	11×17×11.1	7,350	16,000			5,300	80		
200	170	20	175	14×20×13.1	30	30			14,100	34,800	9,900	100

1N=0.102kgf

SMT TYPE

– Two Side Cut Flange Type –

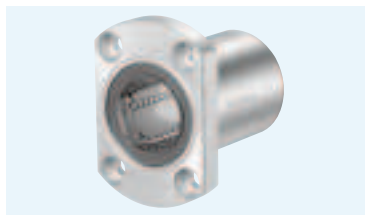

part number structure

example **SMST 25 G UU -SK**

specification
SMT: standard
SMST: anti-corrosion

inner contact diameter (dr)

retainer material
blank: standard/steel
 anti-corrosion/stainless steel
G: resin

outer cylinder
 surface treatment
blank: no surface treatment
SK: electroless nickel plating
LF: low temperature black chrome
 treatment with fluoride coating
SB: black oxide (not available on
 anti-corrosion type)
SC: industrial chrome plating

seals on both sides

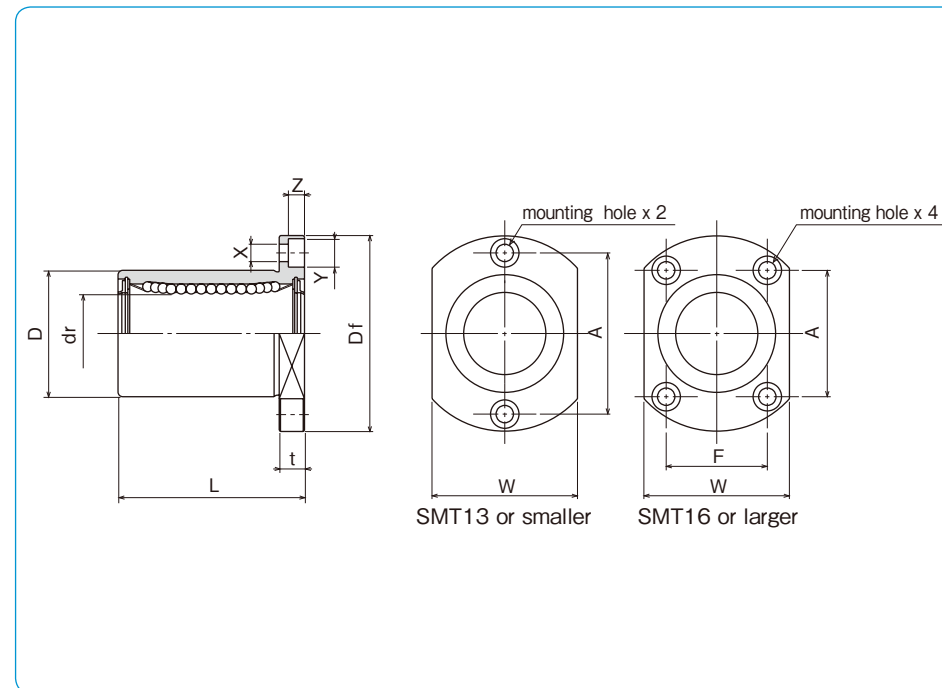

part number*				number of ball circuits	dr mm	dr tolerance μm	major dimensions		
standard steel retainer	anti-corrosion resin retainer	stainless steel retainer	resin retainer				D mm	D tolerance μm	L mm
SMT 6UU	SMT 6GUU	SMST 6UU	SMST 6GUU	4	6	0	12	0	19
SMT 8UU	SMT 8GUU	SMST 8UU	SMST 8GUU	4	8		15	-13	24
SMT 10UU	SMT 10GUU	SMST 10UU	SMST 10GUU	4	10		19	0	29
SMT 12UU	SMT 12GUU	SMST 12UU	SMST 12GUU	4	12	-9	21	0	30
SMT 13UU	SMT 13GUU	SMST 13UU	SMST 13GUU	4	13		23	-16	32
SMT 16UU	SMT 16GUU	SMST 16UU	SMST 16GUU	4	16		28	0	37
SMT 20UU	SMT 20GUU	SMST 20UU	SMST 20GUU	5	20	-10	32	0	42
SMT 25UU	SMT 25GUU	SMST 25UU	SMST 25GUU	6	25		40	-19	59
SMT 30UU	SMT 30GUU	SMST 30UU	SMST 30GUU	6	30		45	0	64

* UU type is standard.

Df mm	W mm	t mm	flange			eccentricity μm	perpendicularity μm	basic load rating		mass g	shaft diameter mm
			A mm	F mm	X×Y×Z mm			dynamic C N	static Co N		
28	18	5	20	—	3.5×6×3.1	12	12	206	265	21	6
32	21	5	24	—	3.5×6×3.1			274	392	33	8
40	25	6	29	—	4.5×7.5×4.1			372	549	64	10
42	27	6	32	—	4.5×7.5×4.1			510	784	68	12
43	29	6	33	—	4.5×7.5×4.1			510	784	81	13
48	34	6	31	22	4.5×7.5×4.1	774	1,180	112	16		
54	38	8	36	24	5.5×9×5.1	15	15	882	1,370	167	20
62	46	8	40	32	5.5×9×5.1			980	1,570	325	25
62	46	8	40	32	5.5×9×5.1			1,570	2,740	388	30
74	51	10	49	35	6.6×11×6.1			1,570	2,740	388	30

1N=0.102kgf

SMF-E TYPE

– Round Flange Type with Pilot End –

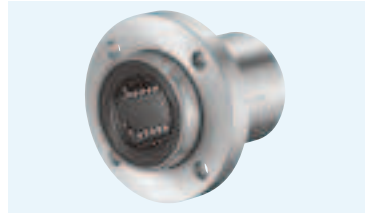

part number structure

example **SMSF 25 G UU-E-SK**

specification
SMF: standard
SMSF: anti-corrosion

inner contact diameter (dr)

retainer material
blank: standard/steel
 anti-corrosion/stainless steel
G: resin

outer cylinder surface treatment
blank: no surface treatment
SK: electroless nickel plating
LF: low temperature black chrome treatment with fluoride coating
SB: black oxide (not available on anti-corrosion type)
SC: industrial chrome plating

with pilot end

seals on both sides

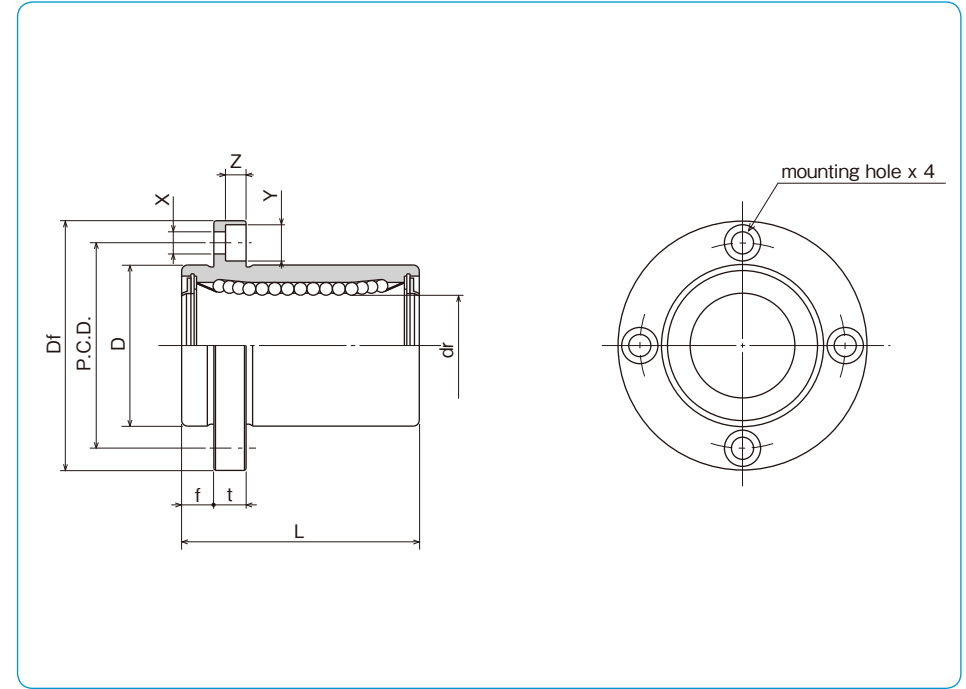

part number*				number of ball circuits	dr	major dimensions			
standard steel retainer	anti-corrosion resin retainer	stainless steel retainer	resin retainer			mm	tolerance μm	D mm	tolerance μm
SMF 6UU-E	SMF 6GUU-E	SMSF 6UU-E	SMSF 6GUU-E	4	6	0	12	0	19
SMF 8UU-E	SMF 8GUU-E	SMSF 8UU-E	SMSF 8GUU-E	4	8	-9	15	-13	24
SMF 10UU-E	SMF 10GUU-E	SMSF 10UU-E	SMSF 10GUU-E	4	10	0	19	0	29
SMF 12UU-E	SMF 12GUU-E	SMSF 12UU-E	SMSF 12GUU-E	4	12	-9	21	0	30
SMF 13UU-E	SMF 13GUU-E	SMSF 13UU-E	SMSF 13GUU-E	4	13	0	23	-16	32
SMF 16UU-E	SMF 16GUU-E	SMSF 16UU-E	SMSF 16GUU-E	4	16	-10	28	-19	37
SMF 20UU-E	SMF 20GUU-E	SMSF 20UU-E	SMSF 20GUU-E	5	20	0	32	0	42
SMF 25UU-E	SMF 25GUU-E	SMSF 25UU-E	SMSF 25GUU-E	6	25	-10	40	-19	59
SMF 30UU-E	SMF 30GUU-E	SMSF 30UU-E	SMSF 30GUU-E	6	30	0	45	0	64
SMF 35UU-E	SMF 35GUU-E	-	-	6	35	-12	52	0	70
SMF 40UU-E	SMF 40GUU-E	-	-	6	40	0	60	-22	80
SMF 50UU-E	SMF 50GUU-E	-	-	6	50	-12	80	-22	100
SMF 60UU-E	SMF 60GUU-E	-	-	6	60	0/-15	90	0/-25	110

* UU type is standard.

f mm	Df mm	flange			eccentricity μm	perpendicularity μm	basic load rating		mass g	shaft diameter mm		
		t mm	P.C.D. mm	X×Y×Z mm			dynamic C N	static Co N				
5	28	5	20	3.5×6×3.1	12	12	206	265	24	6		
5	32	5	24	3.5×6×3.1			274	392	37	8		
6	40	6	29	4.5×7.5×4.1			372	549	72	10		
6	42	6	32	4.5×7.5×4.1			510	784	76	12		
6	43	6	33	4.5×7.5×4.1			510	784	88	13		
6	48	6	38	4.5×7.5×4.1			774	1,180	120	16		
8	54	8	43	5.5×9×5.1	15	15	882	1,370	180	20		
8	62	8	51	5.5×9×5.1			980	1,570	340	25		
10	74	10	60	6.6×11×6.1			1,570	2,740	470	30		
10	82	10	67	6.6×11×6.1	20	20	1,670	3,140	650	35		
13	96	13	78	9×14×8.1			2,160	4,020	1,060	40		
13	116	13	98	9×14×8.1			3,820	7,940	2,200	50		
18	134	18	112	11×17×11.1			25	25	4,700	10,000	3,000	60

1N=0.102kgf

SMK-E TYPE

– Square Flange Type with Pilot End –

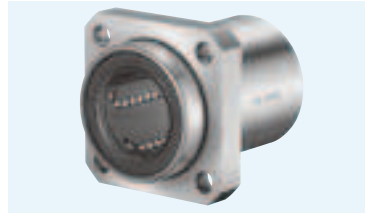

part number structure

example **SMSK 25 G UU-E-SK**

specification
SMK: standard
SMSK: anti-corrosion

inner contact diameter (dr)

retainer material
blank: standard/steel
 anti-corrosion/stainless steel
G: resin

outer cylinder surface treatment
blank: no surface treatment
SK: electroless nickel plating
LF: low temperature black chrome treatment with fluoride coating
SB: black oxide (not available on anti-corrosion type)
SC: industrial chrome plating

with pilot end

seals on both sides

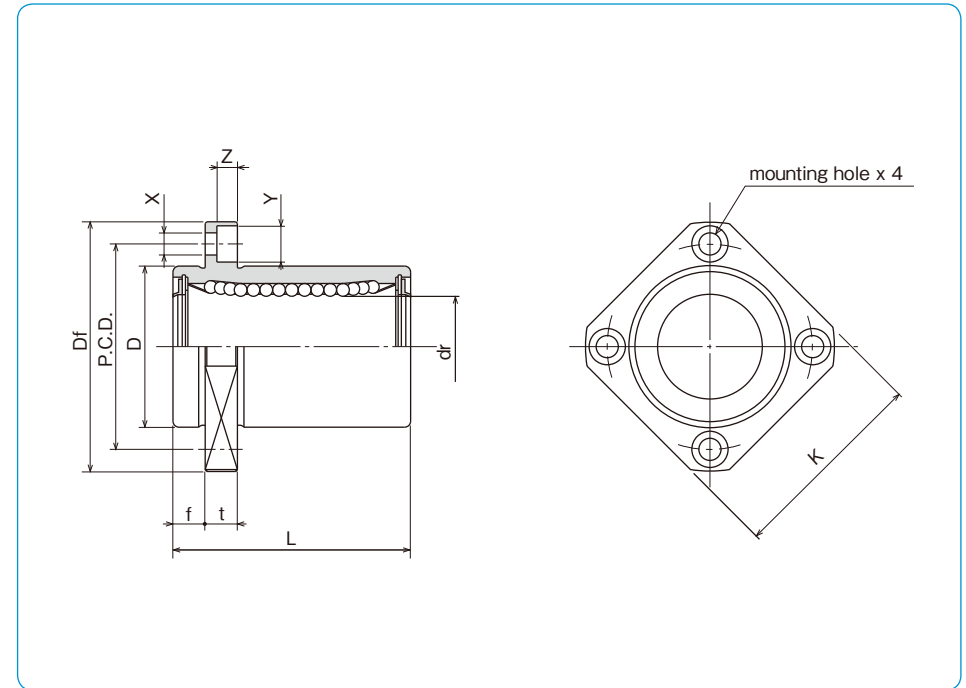

part number*				number of ball circuits	dr		major dimensions		
standard steel retainer	anti-corrosion resin retainer	stainless steel retainer	resin retainer		mm	tolerance μm	D mm	tolerance μm	L ± 0.3 mm
SMK 6UU-E	SMK 6GUU-E	SMSK 6UU-E	SMSK 6GUU-E	4	6	12	0	19	
SMK 8UU-E	SMK 8GUU-E	SMSK 8UU-E	SMSK 8GUU-E	4	8	15	-13	24	
SMK 10UU-E	SMK 10GUU-E	SMSK 10UU-E	SMSK 10GUU-E	4	10	19	0	29	
SMK 12UU-E	SMK 12GUU-E	SMSK 12UU-E	SMSK 12GUU-E	4	12	21	0	30	
SMK 13UU-E	SMK 13GUU-E	SMSK 13UU-E	SMSK 13GUU-E	4	13	23	-16	32	
SMK 16UU-E	SMK 16GUU-E	SMSK 16UU-E	SMSK 16GUU-E	4	16	28		37	
SMK 20UU-E	SMK 20GUU-E	SMSK 20UU-E	SMSK 20GUU-E	5	20	32	0	42	
SMK 25UU-E	SMK 25GUU-E	SMSK 25UU-E	SMSK 25GUU-E	6	25	40	-19	59	
SMK 30UU-E	SMK 30GUU-E	SMSK 30UU-E	SMSK 30GUU-E	6	30	45		64	
SMK 35UU-E	SMK 35GUU-E	—	—	6	35	52	0	70	
SMK 40UU-E	SMK 40GUU-E	—	—	6	40	60	-12	80	
SMK 50UU-E	SMK 50GUU-E	—	—	6	50	80	-22	100	
SMK 60UU-E	SMK 60GUU-E	—	—	6	60	90	0/-15	110	

* UU type is standard.

f mm	Df mm	flange				eccentricity μm	perpendicularity μm	basic load rating		mass g	shaft diameter mm
		K mm	t mm	P.C.D. mm	X×Y×Z mm			dynamic C N	static Co N		
5	28	22	5	20	3.5×6×3.1	12	12	206	265	18	6
5	32	25	5	24	3.5×6×3.1			274	392	29	8
6	40	30	6	29	4.5×7.5×4.1			372	549	52	10
6	42	32	6	32	4.5×7.5×4.1			510	784	57	12
6	43	34	6	33	4.5×7.5×4.1			510	784	72	13
6	48	37	6	38	4.5×7.5×4.1			774	1,180	104	16
8	54	42	8	43	5.5×9×5.1	15	15	882	1,370	145	20
8	62	50	8	51	5.5×9×5.1			980	1,570	300	25
10	74	58	10	60	6.6×11×6.1			1,570	2,740	375	30
10	82	64	10	67	6.6×11×6.1			1,670	3,140	560	35
13	96	75	13	78	9×14×8.1	20	20	2,160	4,020	880	40
13	116	92	13	98	9×14×8.1			3,820	7,940	2,000	50
18	134	106	18	112	11×17×11.1			4,700	10,000	2,560	60

1N=0.102kgf

SMT-E TYPE

– Two Side Cut Pilot End Flange Type –



part number structure

example **SMST 25 G UU-E-SK**

specification
SMT: standard
SMST: anti-corrosion

inner contact diameter (dr)

retainer material
blank: standard/steel
 anti-corrosion/stainless steel
G: resin

outer cylinder surface treatment
blank: no surface treatment
SK: electroless nickel plating
LF: low temperature black chrome treatment with fluoride coating
SB: black oxide (not available on anti-corrosion type)
SC: industrial chrome plating

with pilot end

seals on both sides

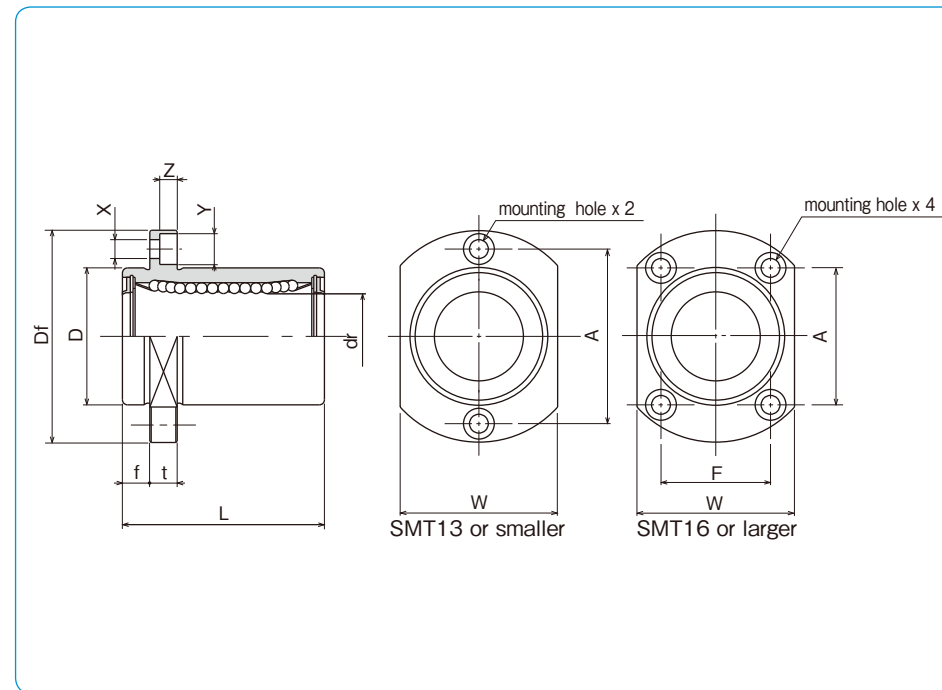

part number*				number of ball circuits	dr		major dimensions		
standard steel retainer	standard resin retainer	anti-corrosion stainless retainer	anti-corrosion resin retainer		mm	tolerance μm	D mm	tolerance μm	L ± 0.3 mm
SMT 6UU-E	SMT 6GUU-E	SMST 6UU-E	SMST 6GUU-E	4	6	12	0	19	
SMT 8UU-E	SMT 8GUU-E	SMST 8UU-E	SMST 8GUU-E	4	8	15	-13	24	
SMT10UU-E	SMT10GUU-E	SMST10UU-E	SMST10GUU-E	4	10	19	0	29	
SMT12UU-E	SMT12GUU-E	SMST12UU-E	SMST12GUU-E	4	12	21	0	30	
SMT13UU-E	SMT13GUU-E	SMST13UU-E	SMST13GUU-E	4	13	23	-16	32	
SMT16UU-E	SMT16GUU-E	SMST16UU-E	SMST16GUU-E	4	16	28		37	
SMT20UU-E	SMT20GUU-E	SMST20UU-E	SMST20GUU-E	5	20	32	0	42	
SMT25UU-E	SMT25GUU-E	SMST25UU-E	SMST25GUU-E	6	25	40	-19	59	
SMT30UU-E	SMT30GUU-E	SMST30UU-E	SMST30GUU-E	6	30	45		64	

* UU type is standard.

f mm	Df mm	flange				eccentricity μm	perpendicularity μm	basic load rating		mass g	shaft diameter mm
		W mm	t mm	A mm	F mm			dynamic C N	static Co N		
5	28	18	5	20	—	12	12	206	265	21	6
5	32	21	5	24	3.5×6×3.1			274	392	33	8
6	40	25	6	29	4.5×7.5×4.1			372	549	64	10
6	42	27	6	32	4.5×7.5×4.1			510	784	68	12
6	43	29	6	33	4.5×7.5×4.1	510	784	81	13		
6	48	34	6	31	22	4.5×7.5×4.1	774	1,180	112	16	
8	54	38	8	36	24	5.5×9×5.1	882	1,370	167	20	
8	62	46	8	40	32	5.5×9×5.1	980	1,570	325	25	
10	74	51	10	49	35	6.6×11×6.1	1,570	2,740	388	30	

1N=0.102kgf

SMK-G-L TYPE

– Square Flange Long type –

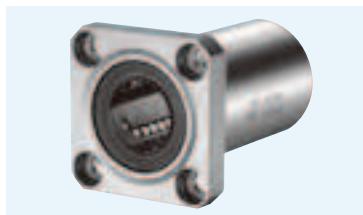

part number structure

example **SMK25G-LUU-SK**

SMK type	inner contact diameter (dr)	resin retainer	outer cylinder surface treatment	seals on both sides	long type
----------	-----------------------------	----------------	----------------------------------	---------------------	-----------

blank: no surface treatment
SK: electroless nickel plating
LF: low temperature black chrome treatment with fluoride coating
SB: black oxide (not available on anti-corrosion type)
SC: industrial chrome plating

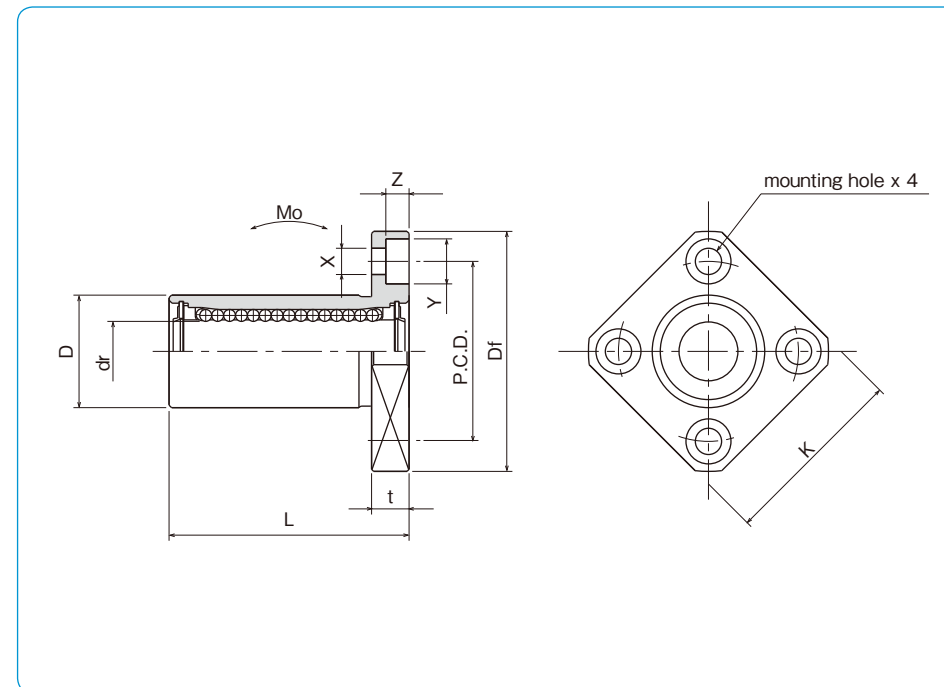

part number*	number of ball circuits	dr		D		major dimensions				
		mm	tolerance μm	mm	tolerance μm	L ± 0.3 mm	Df mm	K mm	t mm	flange P.C.D. mm
SMK 6G-LUU	4	6	0	12	0	26	28	22	5	20
SMK 8G-LUU	4	8		15	-13	32	32	25	5	24
SMK10G-LUU	4	10		19	-16	39	40	30	6	29
SMK12G-LUU	4	12		21		0	41	42	32	6
SMK13G-LUU	4	13	23	6		33				
SMK16G-LUU	4	16	28	-19	53	48	37	6	38	
SMK20G-LUU	5	20	32		0	59	54	42	8	43
SMK25G-LUU	6	25	-12	40	-19	83	62	50	8	51
SMK30G-LUU	6	30		45		90	74	58	10	60

* UU type is standard.

X×Y×Z mm	eccentricity μm	perpendicularity μm	basic load rating		allowable static moment M_o N·m	mass g	shaft diameter mm
			dynamic C N	static C_o N			
3.5×6×3.1	15	15	262	476	1.15	20	6
3.5×6×3.1			352	615	1.94	32	8
4.5×7.5×4.1			493	1,005	3.98	59	10
4.5×7.5×4.1			637	1,430	6.26	67	12
4.5×7.5×4.1			682	1,560	7.68	88	13
4.5×7.5×4.1	20	20	1,039	2,350	13.2	125	16
5.5×9×5.1			1,160	2,740	17.9	170	20
5.5×9×5.1			1,300	2,960	27.2	380	25
5.5×9×5.1			2,160	5,880	61.3	460	30
6.6×11×6.1							

1N≐0.102kgf 1N·m≐0.102kgf·m

SMF-W TYPE

– Round Flange Double-Wide Type –

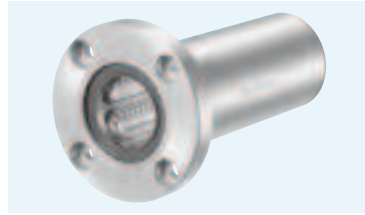

part number structure

example **SMSF 25 G W UU -SK**

specification
SMF: standard
SMSF: anti-corrosion

inner contact diameter (dr)

retainer material
blank: standard/steel
 anti-corrosion/stainless steel
G: resin

outer cylinder surface treatment
blank: no surface treatment
SK: electroless nickel plating
LF: low temperature black chrome treatment with fluoride coating
SB: black oxide (not available on anti-corrosion type)
SC: industrial chrome plating

seal
blank: without seal
UU: seals on both sides

double-wide type

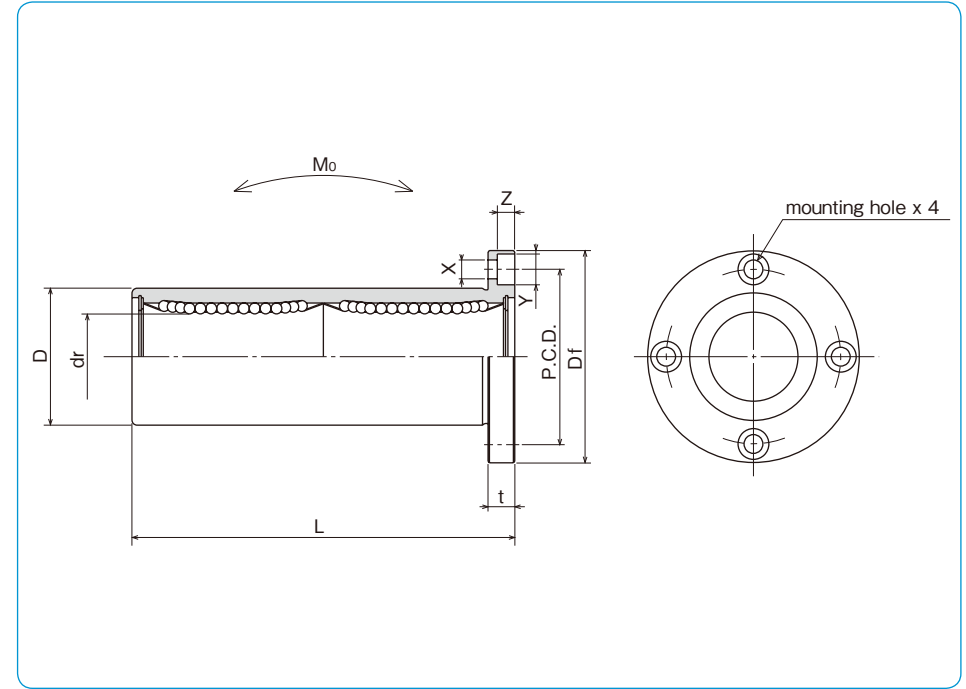

part number				number of ball circuits	dr		major dimensions		
standard steel retainer	anti-corrosion resin retainer	stainless steel retainer	resin retainer		mm	tolerance μm	D mm	tolerance μm	L ± 0.3 mm
SMF 6W	SMF 6GW	SMSF 6W	SMSF 6GW	4	6	0	12	0	35
SMF 8W	SMF 8GW	SMSF 8W	SMSF 8GW	4	8	0	15	-13	45
SMF 10W	SMF 10GW	SMSF 10W	SMSF 10GW	4	10	0	19	0	55
SMF 12W	SMF 12GW	SMSF 12W	SMSF 12GW	4	12	-10	21	0	57
SMF 13W	SMF 13GW	SMSF 13W	SMSF 13GW	4	13	0	23	-16	61
SMF 16W	SMF 16GW	SMSF 16W	SMSF 16GW	4	16	0	28	0	70
SMF 20W	SMF 20GW	SMSF 20W	SMSF 20GW	5	20	0	32	0	80
SMF 25W	SMF 25GW	SMSF 25W	SMSF 25GW	6	25	-12	40	-19	112
SMF 30W	SMF 30GW	SMSF 30W	SMSF 30GW	6	30	0	45	0	123
SMF 35W	SMF 35GW	SMSF 35W	SMSF 35GW	6	35	0	52	0	135
SMF 40W	SMF 40GW	SMSF 40W	SMSF 40GW	6	40	-15	60	-22	151
SMF 50W	SMF 50GW	SMSF 50W	SMSF 50GW	6	50	0	80	0	192
SMF 60W	SMF 60GW	SMSF 60W	SMSF 60GW	6	60	0/-20	90	0/-25	209

Df mm	t mm	flange P.C.D. mm	X×Y×Z mm	eccentricity μm	perpendicularity μm	basic load rating		allowable static moment Mo N·m	mass g	shaft diameter mm
						dynamic C N	static Co N			
28	5	20	3.5×6×3.1	15	15	323	530	2.18	31	6
32	5	24	3.5×6×3.1			431	784	4.31	51	8
40	6	29	4.5×7.5×4.1			588	1,100	7.24	98	10
42	6	32	4.5×7.5×4.1			813	1,570	10.9	110	12
43	6	33	4.5×7.5×4.1			813	1,570	11.6	130	13
48	6	38	4.5×7.5×4.1			1,230	2,350	19.7	190	16
54	8	43	5.5×9×5.1	20	20	1,400	2,740	26.8	260	20
62	8	51	5.5×9×5.1			1,560	3,140	43.4	540	25
74	10	60	6.6×11×6.1			2,490	5,490	82.8	680	30
82	10	67	6.6×11×6.1			2,650	6,270	110	1,020	35
96	13	78	9×14×8.1	25	25	3,430	8,040	147	1,570	40
116	13	98	9×14×8.1			6,080	15,900	397	3,600	50
134	18	112	11×17×11.1			7,550	20,000	530	4,500	60

1N≐0.102kgf 1N·m≐0.102kgf·m

SMK-W TYPE

– Square Flange Double-Wide Type –

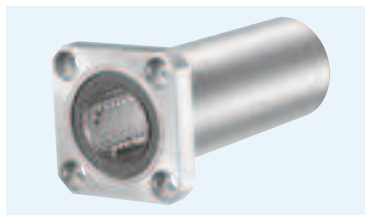

part number structure

example **SMSK 25 G W UU -SK**

specification SMK: standard SMSK: anti-corrosion	outer cylinder surface treatment blank: no surface treatment SK: electroless nickel plating LF: low temperature black chrome treatment with fluoride coating SB: black oxide (not available on anti-corrosion type) SC: industrial chrome plating
inner contact diameter (dr)	seal blank: without seal UU: seals on both sides
retainer material blank: standard/steel anti-corrosion/stainless steel G: resin	double-wide type

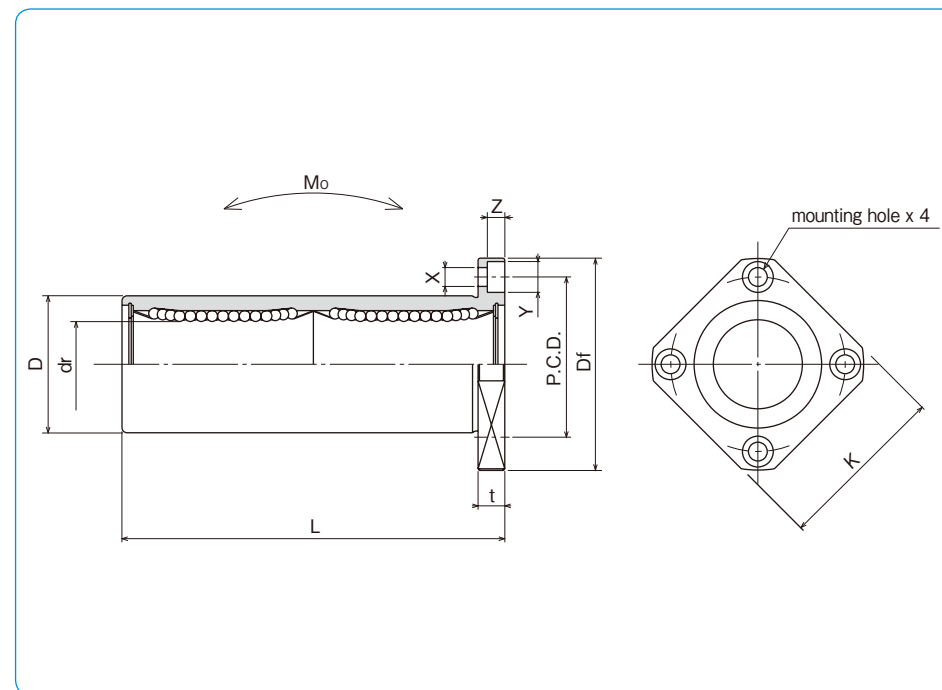

part number				number of ball circuits	dr		major dimensions		
standard steel retainer	resin retainer	anti-corrosion stainless retainer	resin retainer		mm	tolerance μm	D mm	tolerance μm	L ± 0.3 mm
SMK 6W	SMK 6GW	SMSK 6W	SMSK 6GW	4	6	0	12	0	35
SMK 8W	SMK 8GW	SMSK 8W	SMSK 8GW	4	8	0	15	-13	45
SMK 10W	SMK 10GW	SMSK 10W	SMSK 10GW	4	10	0	19	0	55
SMK 12W	SMK 12GW	SMSK 12W	SMSK 12GW	4	12	-10	21	0	57
SMK 13W	SMK 13GW	SMSK 13W	SMSK 13GW	4	13	0	23	-16	61
SMK 16W	SMK 16GW	SMSK 16W	SMSK 16GW	4	16	0	28	0	70
SMK 20W	SMK 20GW	SMSK 20W	SMSK 20GW	5	20	0	32	0	80
SMK 25W	SMK 25GW	SMSK 25W	SMSK 25GW	6	25	-12	40	-19	112
SMK 30W	SMK 30GW	SMSK 30W	SMSK 30GW	6	30	0	45	0	123
SMK 35W	SMK 35GW	SMSK 35W	SMSK 35GW	6	35	0	52	0	135
SMK 40W	SMK 40GW	SMSK 40W	SMSK 40GW	6	40	-15	60	-22	151
SMK 50W	SMK 50GW	SMSK 50W	SMSK 50GW	6	50	0	80	0	192
SMK 60W	SMK 60GW	SMSK 60W	SMSK 60GW	6	60	0/-20	90	0/-25	209

Df mm	K mm	flange			eccentricity μm	perpendicularity μm	basic load rating		allowable static moment $\text{N} \cdot \text{m}$	mass g	shaft diameter mm
		t mm	P.C.D. mm	X × Y × Z mm			dynamic C N	static Co N			
28	22	5	20	3.5 × 6 × 3.1	15	15	323	530	2.18	25	6
32	25	5	24	3.5 × 6 × 3.1			431	784	4.31	43	8
40	30	6	29	4.5 × 7.5 × 4.1			588	1,100	7.24	78	10
42	32	6	32	4.5 × 7.5 × 4.1			813	1,570	10.9	90	12
43	34	6	33	4.5 × 7.5 × 4.1			813	1,570	11.6	108	13
48	37	6	38	4.5 × 7.5 × 4.1	20	20	1,230	2,350	19.7	165	16
54	42	8	43	5.5 × 9 × 5.1			1,400	2,740	26.8	225	20
62	50	8	51	5.5 × 9 × 5.1			1,560	3,140	43.4	500	25
74	58	10	60	6.6 × 11 × 6.1			2,490	5,490	82.8	590	30
82	64	10	67	6.6 × 11 × 6.1	25	25	2,650	6,270	110	930	35
96	75	13	78	9 × 14 × 8.1			3,430	8,040	147	1,380	40
116	92	13	98	9 × 14 × 8.1			6,080	15,900	397	3,400	50
134	106	18	112	11 × 17 × 11.1			7,550	20,000	530	4,060	60

1N ≒ 0.102kgf 1N · m ≒ 0.102kgf · m

SMT-W TYPE

– Two Side Cut Double-Wide Flange Type –

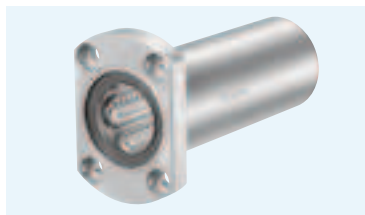

part number structure

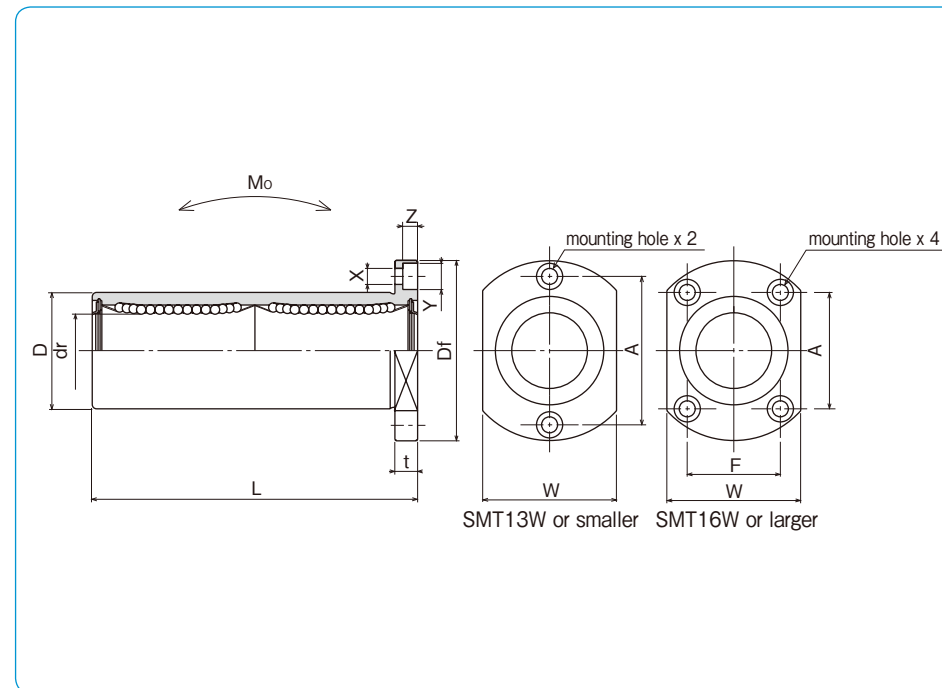
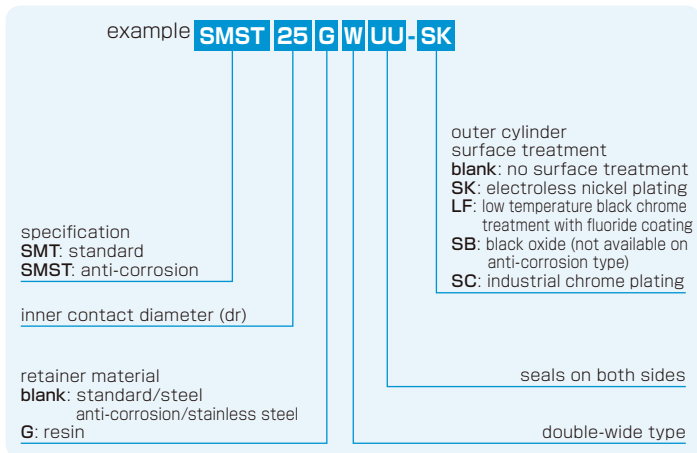

part number*				number of ball circuits	dr		major dimensions		
standard steel retainer	anti-corrosion resin retainer	stainless retainer	resin retainer		mm	tolerance μm	D mm	tolerance μm	L ± 0.3 mm
SMT 6WUU	SMT 6GWUU	SMST 6WUU	SMST 6GWUU	4	6	12	0	35	
SMT 8WUU	SMT 8GWUU	SMST 8WUU	SMST 8GWUU	4	8	15	-13	45	
SMT 10WUU	SMT 10GWUU	SMST 10WUU	SMST 10GWUU	4	10	19	0	55	
SMT 12WUU	SMT 12GWUU	SMST 12WUU	SMST 12GWUU	4	12	21	0	57	
SMT 13WUU	SMT 13GWUU	SMST 13WUU	SMST 13GWUU	4	13	23	-16	61	
SMT 16WUU	SMT 16GWUU	SMST 16WUU	SMST 16GWUU	4	16	28		70	
SMT 20WUU	SMT 20GWUU	SMST 20WUU	SMST 20GWUU	5	20	32	0	80	
SMT 25WUU	SMT 25GWUU	SMST 25WUU	SMST 25GWUU	6	25	40	-19	112	
SMT 30WUU	SMT 30GWUU	SMST 30WUU	SMST 30GWUU	6	30	45		123	

* UU type is standard.

Df mm	W mm	t mm	flange			eccentricity μm	perpendicularity μm	basic load rating		allowable static moment Mo N·m	mass g	shaft diameter mm
			A mm	F mm	X×Y×Z mm			dynamic C N	static Co N			
28	18	5	20	—	3.5×6×3.1	15	15	323	530	2.18	28	6
32	21	5	24	—	3.5×6×3.1			431	784	4.31	47	8
40	25	6	29	—	4.5×7.5×4.1			588	1,100	7.24	90	10
42	27	6	32	—	4.5×7.5×4.1			813	1,570	10.9	102	12
43	29	6	33	—	4.5×7.5×4.1			813	1,570	11.6	123	13
48	34	6	31	22	4.5×7.5×4.1	20	20	1,230	2,350	19.7	182	16
54	38	8	36	24	5.5×9×5.1			1,400	2,740	26.8	247	20
62	46	8	40	32	5.5×9×5.1			1,560	3,140	43.4	525	25
74	51	10	49	35	6.6×11×6.1			2,490	5,490	82.8	645	30

1N \approx 0.102kgf 1N·m \approx 0.102kgf·m

SMFC TYPE

– Center Mount Round Flange Type –

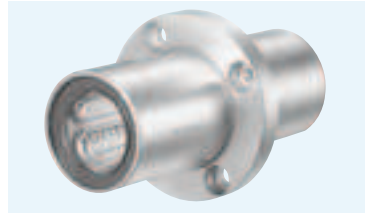

part number structure

example **SMSFC 25 G UU -SK**

specification SMFC: standard SMSFC: anti-corrosion	outer cylinder surface treatment blank: no surface treatment SK: electroless nickel plating LF: low temperature black chrome treatment with fluoride coating SB: black oxide (not available on anti-corrosion type) SC: industrial chrome plating
inner contact diameter (dr)	seal blank: without seal UU: seals on both sides
retainer material blank: standard/steel G: anti-corrosion/stainless steel G: resin	

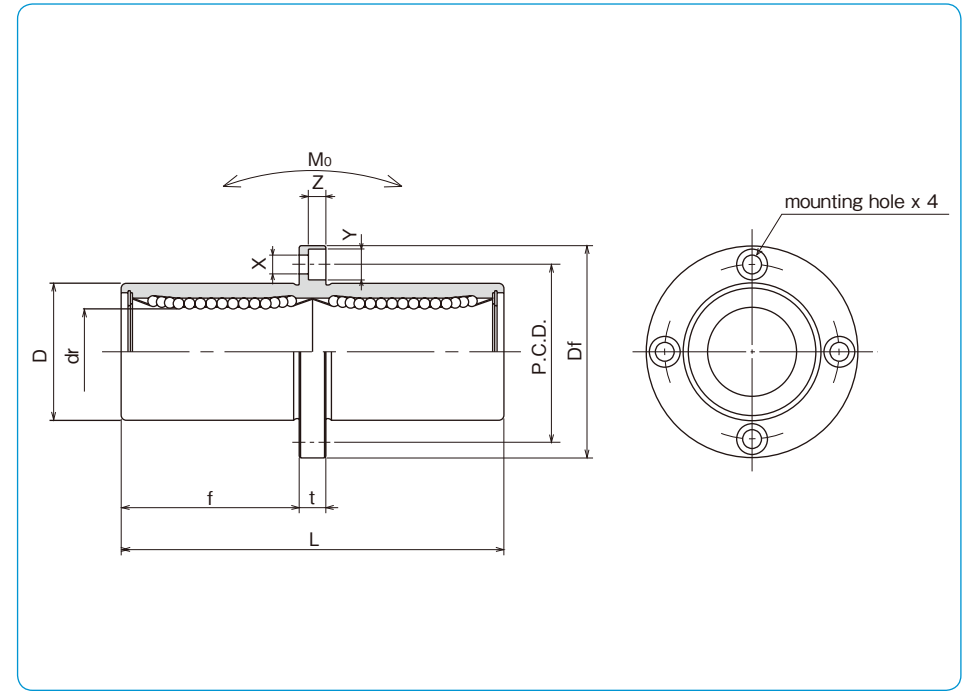

part number				number of ball circuits	dr		major dimensions		
standard steel retainer	resin retainer	anti-corrosion stainless retainer	resin retainer		mm	tolerance μm	D mm	tolerance μm	L ± 0.3 mm
SMFC 6	SMFC 6G	SMSFC 6	SMSFC 6G	4	6	0	12	0	35
SMFC 8	SMFC 8G	SMSFC 8	SMSFC 8G	4	8	0	15	-13	45
SMFC 10	SMFC 10G	SMSFC 10	SMSFC 10G	4	10	0	19	0	55
SMFC 12	SMFC 12G	SMSFC 12	SMSFC 12G	4	12	-10	21	0	57
SMFC 13	SMFC 13G	SMSFC 13	SMSFC 13G	4	13	0	23	-16	61
SMFC 16	SMFC 16G	SMSFC 16	SMSFC 16G	4	16	0	28	0	70
SMFC 20	SMFC 20G	SMSFC 20	SMSFC 20G	5	20	0	32	0	80
SMFC 25	SMFC 25G	SMSFC 25	SMSFC 25G	6	25	-12	40	-19	112
SMFC 30	SMFC 30G	SMSFC 30	SMSFC 30G	6	30	0	45	0	123
SMFC 35	SMFC 35G	SMSFC 35	SMSFC 35G	6	35	0	52	0	135
SMFC 40	SMFC 40G	SMSFC 40	SMSFC 40G	6	40	-15	60	-22	151
SMFC 50	SMFC 50G	SMSFC 50	SMSFC 50G	6	50	0	80	0	192
SMFC 60	SMFC 60G	SMSFC 60	SMSFC 60G	6	60	0/-20	90	0/-25	209

flange					eccentricity μm	perpendicularity μm	basic load rating		allowable static moment $\text{N} \cdot \text{m}$	mass g	shaft diameter mm
f mm	Df mm	t mm	P.C.D. mm	X × Y × Z mm			dynamic C N	static Co N			
15	28	5	20	3.5 × 6 × 3.1	15	15	323	530	2.18	31	6
20	32	5	24	3.5 × 6 × 3.1			431	784	4.31	51	8
24.5	40	6	29	4.5 × 7.5 × 4.1			588	1,100	7.24	98	10
25.5	42	6	32	4.5 × 7.5 × 4.1			813	1,570	10.9	110	12
27.5	43	6	33	4.5 × 7.5 × 4.1			813	1,570	11.6	130	13
32	48	6	38	4.5 × 7.5 × 4.1			1,230	2,350	19.7	190	16
36	54	8	43	5.5 × 9 × 5.1	20	20	1,400	2,740	26.8	260	20
52	62	8	51	5.5 × 9 × 5.1			1,560	3,140	43.4	540	25
56.5	74	10	60	6.6 × 11 × 6.1			2,490	5,490	82.8	680	30
62.5	82	10	67	6.6 × 11 × 6.1	25	25	2,650	6,270	110	1,020	35
69	96	13	78	9 × 14 × 8.1			3,430	8,040	147	1,570	40
89.5	116	13	98	9 × 14 × 8.1			6,080	15,900	397	3,600	50
95.5	134	18	112	11 × 17 × 11.1			7,550	20,000	530	4,500	60

1N ≅ 0.102kgf 1N · m ≅ 0.102kgf · m

SMKC TYPE

– Center Mount Square Flange Type –

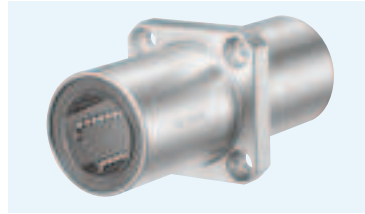

part number structure

example **SMSKC 25 G UU-SK**

specification SMKC : standard SMSKC : anti-corrosion	outer cylinder surface treatment blank : no surface treatment SK : electroless nickel plating LF : low temperature black chrome treatment with fluoride coating SB : black oxide (not available on anti-corrosion type) SC : industrial chrome plating
inner contact diameter (dr)	seal blank : without seal UU : seals on both sides
retainer material blank : standard/steel G : anti-corrosion/stainless steel G : resin	

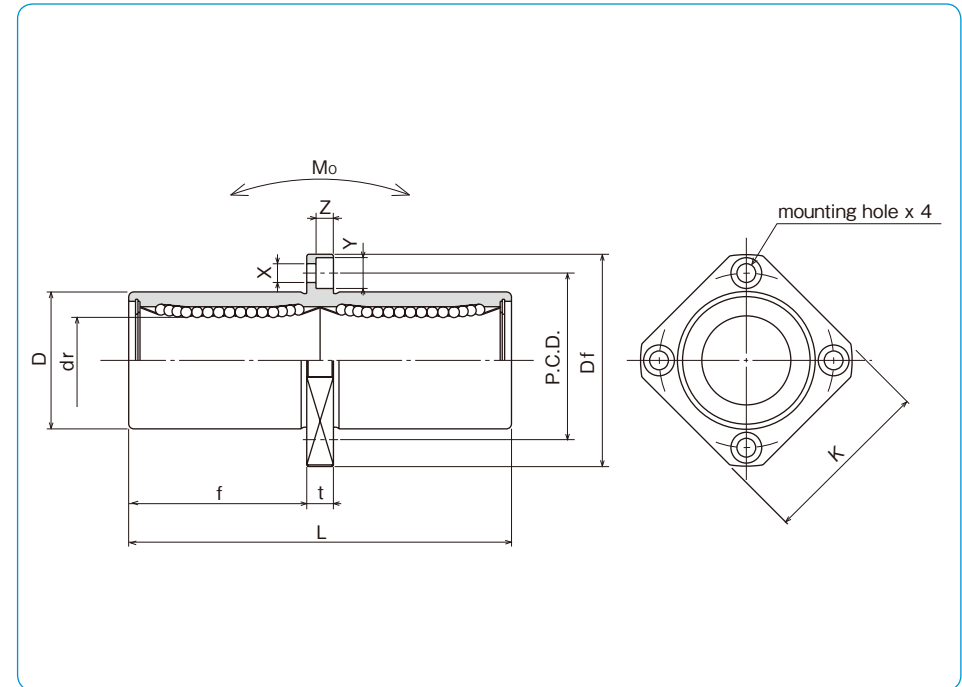

part number				number of ball circuits	major dimensions				
standard steel retainer	resin retainer	anti-corrosion stainless retainer	resin retainer		dr mm	dr tolerance μm	D mm	D tolerance μm	L ± 0.3 mm
SMKC 6	SMKC 6G	SMSKC 6	SMSKC 6G	4	6	0	12	0	35
SMKC 8	SMKC 8G	SMSKC 8	SMSKC 8G	4	8	0	15	-13	45
SMKC 10	SMKC 10G	SMSKC 10	SMSKC 10G	4	10	0	19	0	55
SMKC 12	SMKC 12G	SMSKC 12	SMSKC 12G	4	12	-10	21	0	57
SMKC 13	SMKC 13G	SMSKC 13	SMSKC 13G	4	13	0	23	-16	61
SMKC 16	SMKC 16G	SMSKC 16	SMSKC 16G	4	16	0	28	0	70
SMKC 20	SMKC 20G	SMSKC 20	SMSKC 20G	5	20	0	32	0	80
SMKC 25	SMKC 25G	SMSKC 25	SMSKC 25G	6	25	-12	40	-19	112
SMKC 30	SMKC 30G	SMSKC 30	SMSKC 30G	6	30	0	45	0	123
SMKC 35	SMKC 35G	SMSKC 35	SMSKC 35G	6	35	0	52	0	135
SMKC 40	SMKC 40G	SMSKC 40	SMSKC 40G	6	40	-15	60	-22	151
SMKC 50	SMKC 50G	SMSKC 50	SMSKC 50G	6	50	0	80	0	192
SMKC 60	SMKC 60G	SMSKC 60	SMSKC 60G	6	60	0/-20	90	0/-25	209

f mm	Df mm	flange				eccentricity μm	perpendicularity μm	basic load rating		allowable static moment $\text{N} \cdot \text{m}$	mass g	shaft diameter mm
		K mm	t mm	P.C.D. mm	X×Y×Z mm			dynamic C N	static Co N			
15	28	22	5	20	3.5×6×3.1	15	15	323	530	2.18	25	6
20	32	25	5	24	3.5×6×3.1			431	784	4.31	43	8
24.5	40	30	6	29	4.5×7.5×4.1			588	1,100	7.24	78	10
25.5	42	32	6	32	4.5×7.5×4.1			813	1,570	10.9	90	12
27.5	43	34	6	33	4.5×7.5×4.1			813	1,570	11.6	108	13
32	48	37	6	38	4.5×7.5×4.1			1,230	2,350	19.7	165	16
36	54	42	8	43	5.5×9×5.1	20	20	1,400	2,740	26.8	225	20
52	62	50	8	51	5.5×9×5.1			1,560	3,140	43.4	500	25
56.5	74	58	10	60	6.6×11×6.1			2,490	5,490	82.8	590	30
62.5	82	64	10	67	6.6×11×6.1	25	25	2,650	6,270	110	930	35
69	96	75	13	78	9×14×8.1			3,430	8,040	147	1,380	40
89.5	116	92	13	98	9×14×8.1			6,080	15,900	397	3,400	50
95.5	134	106	18	112	11×17×11.1	30	30	7,550	20,000	530	4,060	60

1N≐0.102kgf 1N · m≐0.102kgf · m

SMTC TYPE

– Two Side Cut Center Flange Type –

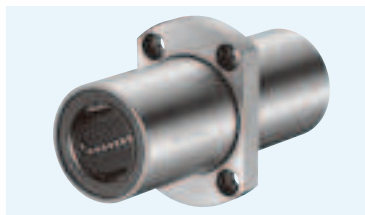

part number structure

example **SMSTC 25 G UU -SK**

specification
SMTC: standard
SMSTC: anti-corrosion

inner contact diameter (dr)

retainer material
blank: standard/steel
 anti-corrosion/stainless steel
G: resin

outer cylinder surface treatment
blank: no surface treatment
SK: electroless nickel plating
LF: low temperature black chrome treatment with fluoride coating
SB: black oxide (not available on anti-corrosion type)
SC: industrial chrome plating

seals on both sides

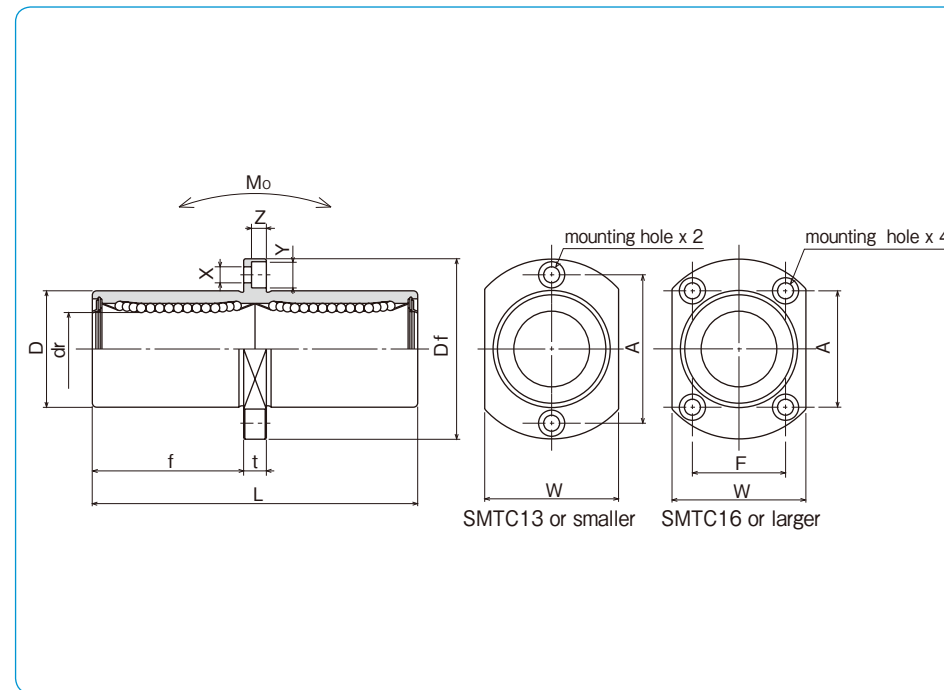

part number*				number of ball circuits	dr		major dimensions		
standard steel retainer	resin retainer	anti-corrosion			mm	tolerance μm	D mm	tolerance μm	L ± 0.3 mm
SMTC 6UU	SMTC 6GUU	SMSTC 6UU	SMSTC 6GUU	4	6	12	0	35	
SMTC 8UU	SMTC 8GUU	SMSTC 8UU	SMSTC 8GUU	4	8	15	-13	45	
SMTC10UU	SMTC10GUU	SMSTC10UU	SMSTC10GUU	4	10	19	0	55	
SMTC12UU	SMTC12GUU	SMSTC12UU	SMSTC12GUU	4	12	21	0	57	
SMTC13UU	SMTC13GUU	SMSTC13UU	SMSTC13GUU	4	13	23	-16	61	
SMTC16UU	SMTC16GUU	SMSTC16UU	SMSTC16GUU	4	16	28		70	
SMTC20UU	SMTC20GUU	SMSTC20UU	SMSTC20GUU	5	20	32	0	80	
SMTC25UU	SMTC25GUU	SMSTC25UU	SMSTC25GUU	6	25	40	-19	112	
SMTC30UU	SMTC30GUU	SMSTC30UU	SMSTC30GUU	6	30	45		123	

* UU type is standard.

flange							eccentricity μm	perpendicularity μm	basic load rating		allowable static moment $\text{N} \cdot \text{m}$	mass g	shaft diameter mm
f mm	Df mm	W mm	t mm	A mm	F mm	X×Y×Z mm			dynamic C N	static Co N			
15	28	18	5	20	—	3.5×6×3.1	15	15	323	530	2.18	28	6
20	32	21	5	24	—	3.5×6×3.1			431	784	4.31	47	8
24.5	40	25	6	29	—	4.5×7.5×4.1			588	1,100	7.24	90	10
25.5	42	27	6	32	—	4.5×7.5×4.1			813	1,570	10.9	102	12
27.5	43	29	6	33	—	4.5×7.5×4.1			813	1,570	11.6	123	13
32	48	34	6	31	22	4.5×7.5×4.1			1,230	2,350	19.7	182	16
36	54	38	8	36	24	5.5×9×5.1	20	20	1,400	2,740	26.8	247	20
52	62	46	8	40	32	5.5×9×5.1			1,560	3,140	43.4	525	25
56.5	74	51	10	49	35	6.6×11×6.1			2,490	5,490	82.8	645	30

1N \approx 0.102kgf 1N \cdot m \approx 0.102kgf \cdot m

SMF-W-E TYPE

— Round Flange Double-Wide Pilot End Type —

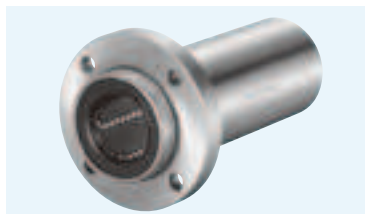

part number structure

example **SMSF 25 G W UU - E - SK**

specification SMF : standard SMSF : anti-corrosion	outer cylinder surface treatment blank : no surface treatment SK : electroless nickel plating LF : low temperature black chrome treatment with fluoride coating SB : black oxide (not available on anti-corrosion type) SC : industrial chrome plating
inner contact diameter (dr)	with pilot end
retainer material blank : standard/steel anti-corrosion/stainless steel G : resin	seals on both sides
double-wide type	

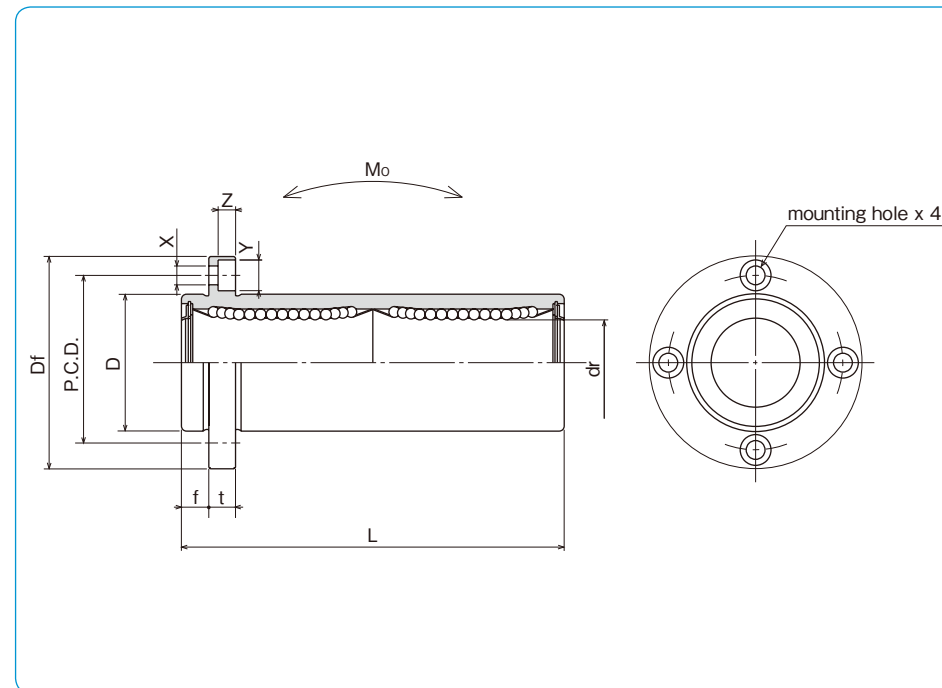

part number*				number of ball circuits	dr mm	tolerance μm	major dimensions		
standard steel retainer	anti-corrosion resin retainer	stainless retainer	resin retainer				D mm	tolerance μm	L ±0.3 mm
SMF 6WUU-E	SMF 6GWUU-E	SMSF 6WUU-E	SMSF 6GWUU-E	4	6	0	12	0	35
SMF 8WUU-E	SMF 8GWUU-E	SMSF 8WUU-E	SMSF 8GWUU-E	4	8	-10	15	-13	45
SMF10WUU-E	SMF10GWUU-E	SMSF10WUU-E	SMSF10GWUU-E	4	10	0	19	0	55
SMF12WUU-E	SMF12GWUU-E	SMSF12WUU-E	SMSF12GWUU-E	4	12	-10	21	0	57
SMF13WUU-E	SMF13GWUU-E	SMSF13WUU-E	SMSF13GWUU-E	4	13	0	23	-16	61
SMF16WUU-E	SMF16GWUU-E	SMSF16WUU-E	SMSF16GWUU-E	4	16	0	28	0	70
SMF20WUU-E	SMF20GWUU-E	SMSF20WUU-E	SMSF20GWUU-E	5	20	-12	32	0	80
SMF25WUU-E	SMF25GWUU-E	SMSF25WUU-E	SMSF25GWUU-E	6	25	0	40	-19	112
SMF30WUU-E	SMF30GWUU-E	SMSF30WUU-E	SMSF30GWUU-E	6	30	-15	45	0	123
SMF35WUU-E	SMF35GWUU-E	—	—	6	35	0	52	0	135
SMF40WUU-E	SMF40GWUU-E	—	—	6	40	-15	60	-22	151
SMF50WUU-E	SMF50GWUU-E	—	—	6	50	0	80	0	192
SMF60WUU-E	SMF60GWUU-E	—	—	6	60	0/-20	90	0/-25	209

* UU type is standard.

f mm	Df mm	flange			eccentricity μm	perpendicularity μm	basic load rating		allowable static moment Mo N·m	mass g	shaft diameter mm
		t mm	P.C.D. mm	X×Y×Z mm			dynamic C N	static Co N			
5	28	5	20	3.5×6×3.1	15	15	323	530	2.18	31	6
5	32	5	24	3.5×6×3.1			431	784	4.31	51	8
6	40	6	29	4.5×7.5×4.1			588	1,100	7.24	98	10
6	42	6	32	4.5×7.5×4.1			813	1,570	10.9	110	12
6	43	6	33	4.5×7.5×4.1			813	1,570	11.6	130	13
6	48	6	38	4.5×7.5×4.1			1,230	2,350	19.7	190	16
8	54	8	43	5.5×9×5.1	20	20	1,400	2,740	26.8	260	20
8	62	8	51	5.5×9×5.1			1,560	3,140	43.4	540	25
10	74	10	60	6.6×11×6.1			2,490	5,490	82.8	680	30
10	82	10	67	6.6×11×6.1			2,650	6,270	110	1,020	35
13	96	13	78	9×14×8.1	25	25	3,430	8,040	147	1,570	40
13	116	13	98	9×14×8.1			6,080	15,900	397	3,600	50
18	134	18	112	11×17×11.1			7,550	20,000	530	4,500	60

1N≐0.102kgf 1N·m≐0.102kgf·m

SMK-W-E TYPE

— Square Flange Double-Wide Pilot End Type —

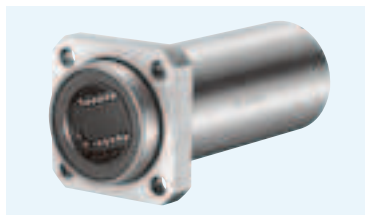

part number structure

example **SMSK 25 G W UU - E - SK**

specification SMK : standard SMSK : anti-corrosion	outer cylinder surface treatment blank : no surface treatment SK : electroless nickel plating LF : low temperature black chrome treatment with fluoride coating SB : black oxide (not available on anti-corrosion type) SC : industrial chrome plating
inner contact diameter (dr)	with pilot end
retainer material blank : standard/steel anti-corrosion/stainless steel G : resin	seals on both sides
double-wide type	

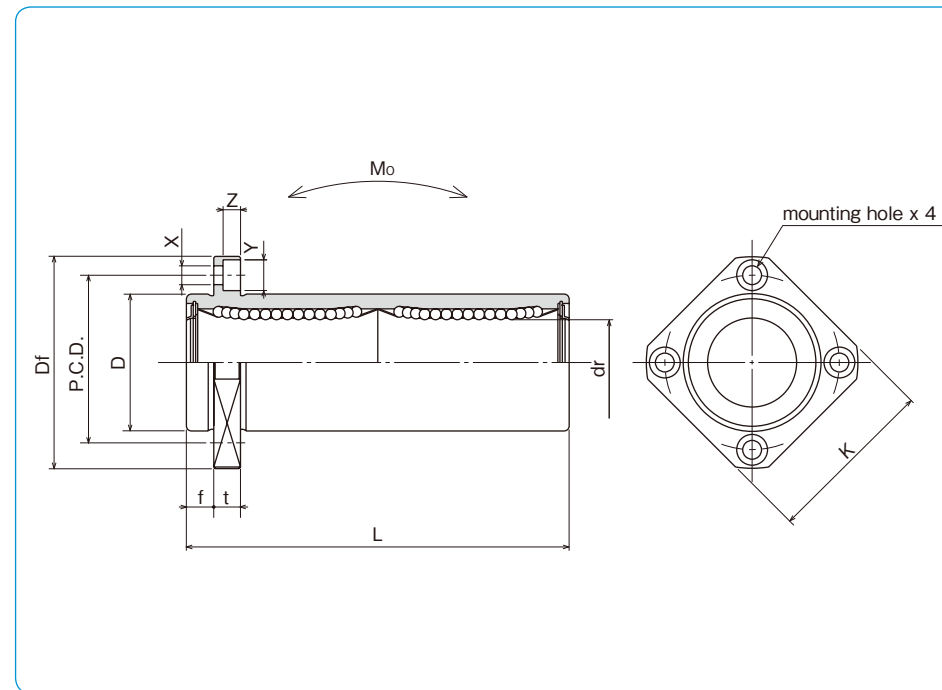

part number*				number of ball circuits	dr mm	dr tolerance μm	major dimensions		
standard steel retainer	anti-corrosion resin retainer	stainless steel retainer	resin retainer				D mm	D tolerance μm	L ±0.3 mm
SMK 6WUU-E	SMK 6GWUU-E	SMSK 6WUU-E	SMSK 6GWUU-E	4	6	0	12	0	35
SMK 8WUU-E	SMK 8GWUU-E	SMSK 8WUU-E	SMSK 8GWUU-E	4	8	-10	15	-13	45
SMK 10WUU-E	SMK 10GWUU-E	SMSK 10WUU-E	SMSK 10GWUU-E	4	10	0	19	0	55
SMK 12WUU-E	SMK 12GWUU-E	SMSK 12WUU-E	SMSK 12GWUU-E	4	12	-10	21	0	57
SMK 13WUU-E	SMK 13GWUU-E	SMSK 13WUU-E	SMSK 13GWUU-E	4	13	0	23	-16	61
SMK 16WUU-E	SMK 16GWUU-E	SMSK 16WUU-E	SMSK 16GWUU-E	4	16	-10	28	-16	70
SMK 20WUU-E	SMK 20GWUU-E	SMSK 20WUU-E	SMSK 20GWUU-E	5	20	0	32	0	80
SMK 25WUU-E	SMK 25GWUU-E	SMSK 25WUU-E	SMSK 25GWUU-E	6	25	-12	40	-19	112
SMK 30WUU-E	SMK 30GWUU-E	SMSK 30WUU-E	SMSK 30GWUU-E	6	30	0	45	0	123
SMK 35WUU-E	SMK 35GWUU-E	—	—	6	35	-15	52	0	135
SMK 40WUU-E	SMK 40GWUU-E	—	—	6	40	0	60	-22	151
SMK 50WUU-E	SMK 50GWUU-E	—	—	6	50	-15	80	-22	192
SMK 60WUU-E	SMK 60GWUU-E	—	—	6	60	0/-20	90	0/-25	209

* UU type is standard.

f mm	Df mm	flange				eccentricity μm	perpendicularity μm	basic load rating		allowable static moment Mo N·m	mass g	shaft diameter mm
		K mm	t mm	P.C.D. mm	X×Y×Z mm			dynamic C N	static Co N			
5	28	22	5	20	3.5×6×3.1	15	15	323	530	2.18	25	6
5	32	25	5	24	3.5×6×3.1			431	784	4.31	43	8
6	40	30	6	29	4.5×7.5×4.1			588	1,100	7.24	78	10
6	42	32	6	32	4.5×7.5×4.1			813	1,570	10.9	90	12
6	43	34	6	33	4.5×7.5×4.1			813	1,570	11.6	108	13
6	48	37	6	38	4.5×7.5×4.1			1,230	2,350	19.7	165	16
8	54	42	8	43	5.5×9×5.1	20	20	1,400	2,740	26.8	225	20
8	62	50	8	51	5.5×9×5.1			1,560	3,140	43.4	500	25
10	74	58	10	60	6.6×11×6.1			2,490	5,490	82.8	590	30
10	82	64	10	67	6.6×11×6.1			2,650	6,270	110	930	35
13	96	75	13	78	9×14×8.1	25	25	3,430	8,040	147	1,380	40
13	116	92	13	98	9×14×8.1			6,080	15,900	397	3,400	50
18	134	106	18	112	11×17×11.1			7,550	20,000	530	4,060	60

1N≐0.102kgf 1N·m≐0.102kgf·m

SMT-W-E TYPE

— Two Side Cut Double-Wide Flange Pilot End Type —

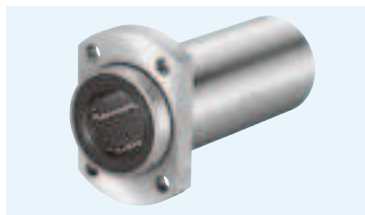

part number structure

example **SMST 25 G W UU-E-SK**

specification SMT: standard SMST: anti-corrosion	inner contact diameter (dr)	retainer material blank: standard/steel anti-corrosion/stainless steel G: resin	double-wide type	outer cylinder surface treatment blank: no surface treatment SK: electroless nickel plating LF: low temperature black chrome treatment with fluoride coating SB: black oxide (not available on anti-corrosion type) SC: industrial chrome plating	with pilot end	seals on both sides
--	-----------------------------	--	------------------	--	----------------	---------------------

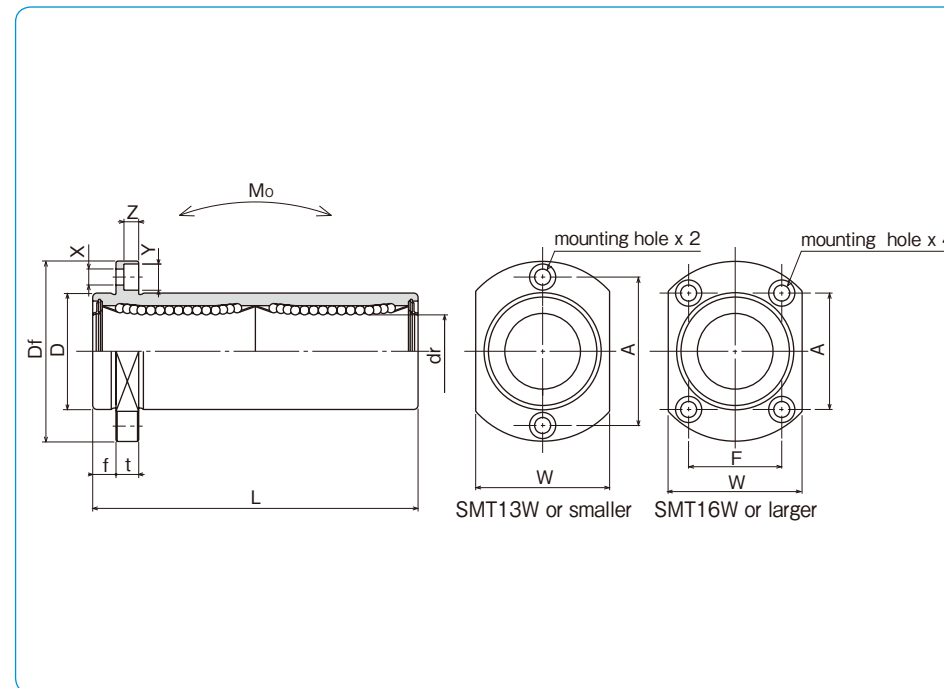

part number*				number of ball circuits	dr		major dimensions		
standard steel retainer	standard resin retainer	anti-corrosion stainless retainer	anti-corrosion resin retainer		mm	tolerance μm	D mm	tolerance μm	L ± 0.3 mm
SMT 6WUU-E	SMT 6GWUU-E	SMST 6WUU-E	SMST 6GWUU-E	4	6	12	0	35	
SMT 8WUU-E	SMT 8GWUU-E	SMST 8WUU-E	SMST 8GWUU-E	4	8	15	-13	45	
SMT10WUU-E	SMT10GWUU-E	SMST10WUU-E	SMST10GWUU-E	4	10	19	0	55	
SMT12WUU-E	SMT12GWUU-E	SMST12WUU-E	SMST12GWUU-E	4	12	21	0	57	
SMT13WUU-E	SMT13GWUU-E	SMST13WUU-E	SMST13GWUU-E	4	13	23	-16	61	
SMT16WUU-E	SMT16GWUU-E	SMST16WUU-E	SMST16GWUU-E	4	16	28	0	70	
SMT20WUU-E	SMT20GWUU-E	SMST20WUU-E	SMST20GWUU-E	5	20	32	0	80	
SMT25WUU-E	SMT25GWUU-E	SMST25WUU-E	SMST25GWUU-E	6	25	40	-19	112	
SMT30WUU-E	SMT30GWUU-E	SMST30WUU-E	SMST30GWUU-E	6	30	45	0	123	

* UU type is standard.

flange							eccentricity μm	perpendicularity μm	basic load rating		allowable static moment $\text{N} \cdot \text{m}$	mass g	shaft diameter mm
f mm	Df mm	W mm	t mm	A mm	F mm	X×Y×Z mm			dynamic C N	static Co N			
5	28	18	5	20	—	3.5×6×3.1	15	15	323	530	2.18	28	6
5	32	21	5	24	—	3.5×6×3.1			431	784	4.31	47	8
6	40	25	6	29	—	4.5×7.5×4.1			588	1,100	7.24	90	10
6	42	27	6	32	—	4.5×7.5×4.1			813	1,570	10.9	102	12
6	43	29	6	33	—	4.5×7.5×4.1			813	1,570	11.6	123	13
6	48	34	6	31	22	4.5×7.5×4.1			1,230	2,350	19.7	182	16
8	54	38	8	36	24	5.5×9×5.1	20	20	1,400	2,740	26.8	247	20
8	62	46	8	40	32	5.5×9×5.1			1,560	3,140	43.4	525	25
10	74	51	10	49	35	6.6×11×6.1			2,490	5,490	82.8	645	30

1N \approx 0.102kgf 1N \cdot m \approx 0.102kgf \cdot m

TRF TYPE

– Triple-Wide Round Flange Type –

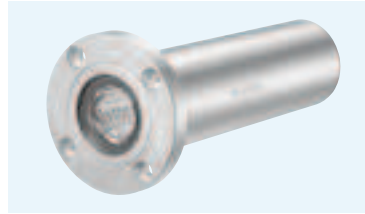

part number structure

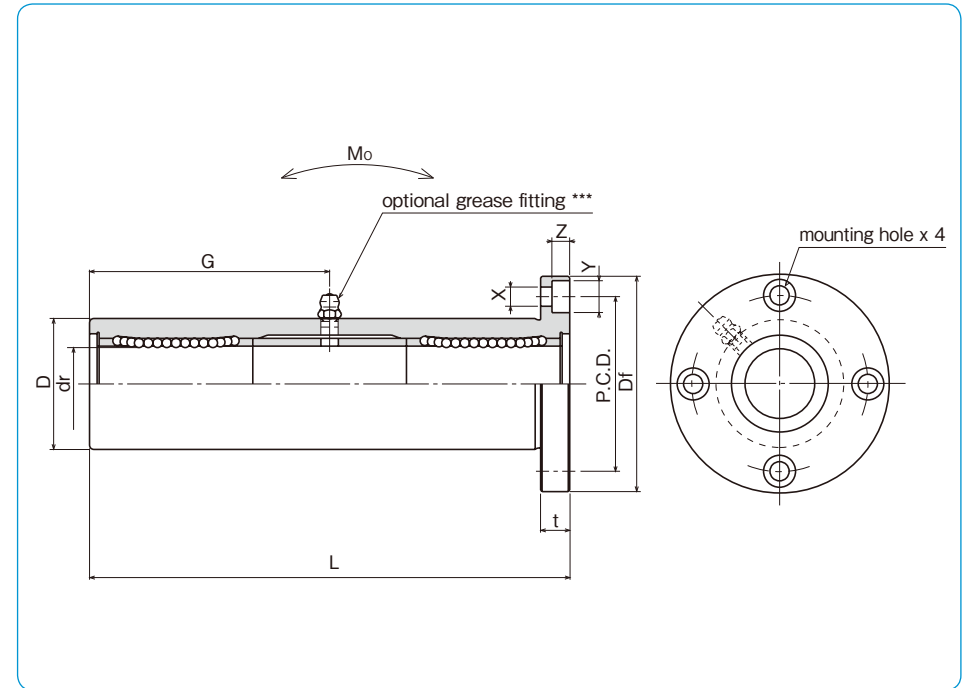
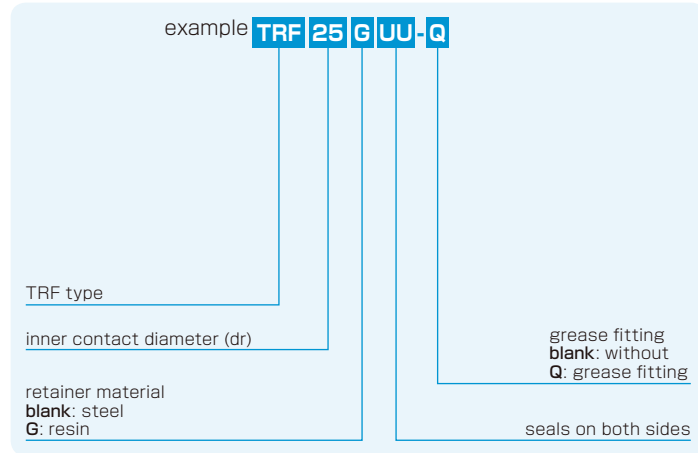

part number*		number of ball circuits	dr		major dimensions		
steel retainer	resin retainer		mm	tolerance μm	D mm	tolerance μm	L ± 0.3 mm
TRF 6UU	TRF 6GUU	4	6		15	0/-18	51
TRF 8UU	TRF 8GUU	4	8	0	19		66
TRF 10UU	TRF 10GUU	4	10	-12	23	0	80
TRF 12UU	TRF 12GUU	4	12		26	-21	84
TRF 13UU	TRF 13GUU	4	13	0	28		90
TRF 16UU	TRF 16GUU	4	16	-15	32	0	103
TRF 20UU	TRF 20GUU	5	20	0	40	-25	118
TRF 25UU	TRF 25GUU	6	25	-18	45		165
TRF 30UU	TRF 30GUU	6	30		52	0	182
TRF 35UU	TRF 35GUU	6	35	0	60	-30	200
TRF 40UU	TRF 40GUU	6	40	-21	65		230
TRF 50UU	TRF 50GUU	6	50		85	0	290
TRF 60UU	TRF 60GUU	6	60	0/-25	100	-35	310

* UU type is standard.

** Outer cylinder is treated with electroless nickel plating.

*** TRF6: A-MT6x1 TRF8: A-M6x1 TRF10~30: A-M6F TRF35~60: A-R1/8

Df mm	t mm	flange P.C.D. mm	X×Y×Z mm	grease fitting G mm	eccentricity μm	perpendicularity μm	basic load rating		allowable static moment $\text{N} \cdot \text{m}$	mass g	shaft diameter mm
							dynamic C N	static Co N			
32	5	24	3.5×6×3.1	20.5	20	20	323	530	8.2	66	6
40	6	29	4.5×7.5×4.1	29			431	784	16.0	135	8
43	6	33	4.5×7.5×4.1	38			588	1,100	27.0	205	10
46	6	36	4.5×7.5×4.1	41			813	1,570	40.1	248	12
48	6	38	4.5×7.5×4.1	45			813	1,570	42.9	308	13
54	8	43	5.5×9×5.1	51			1,230	2,350	73.5	412	16
62	8	51	5.5×9×5.1	59	25	25	1,400	2,740	98.0	752	20
74	10	60	6.6×11×6.1	82.5			1,560	3,140	157	1,244	25
82	10	67	6.6×11×6.1	91			2,490	5,490	297	1,636	30
96	13	78	9×14×8.1	100			2,650	6,270	373	2,580	35
101	13	83	9×14×8.1	115			3,430	8,040	553	2,950	40
129	18	107	11×17×11.1	145			6,080	15,900	1,370	6,860	50
144	18	122	11×17×11.1	155	7,550	20,000	1,800	9,660	60		

1N≐0.102kgf 1N·m≐0.102kgf·m

TRK TYPE

– Triple-Wide Square Flange Type –

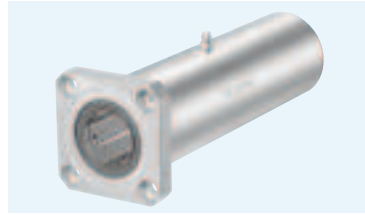

part number structure

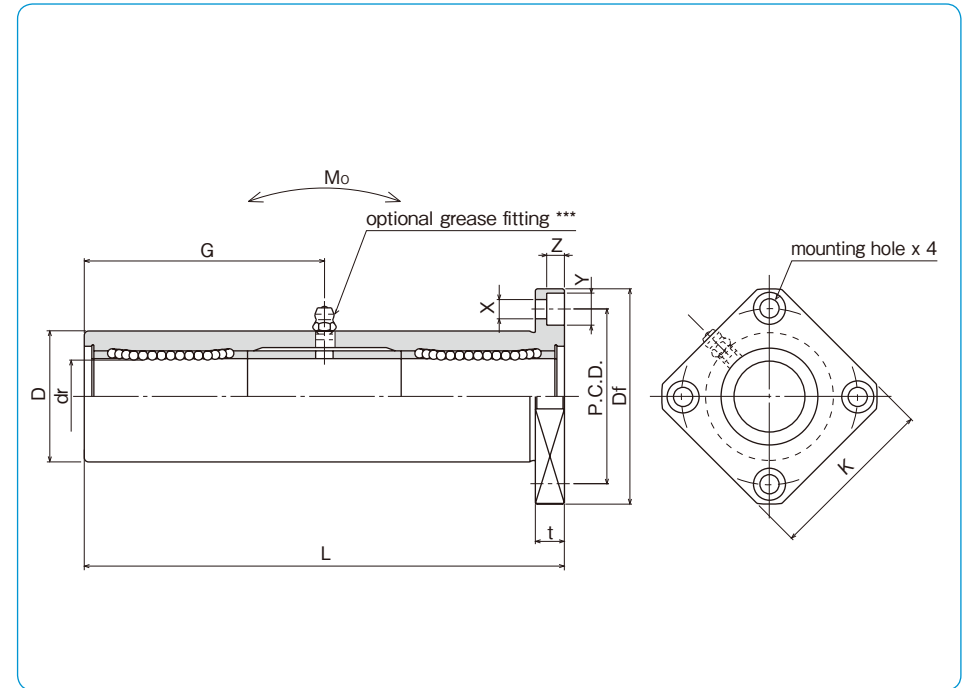
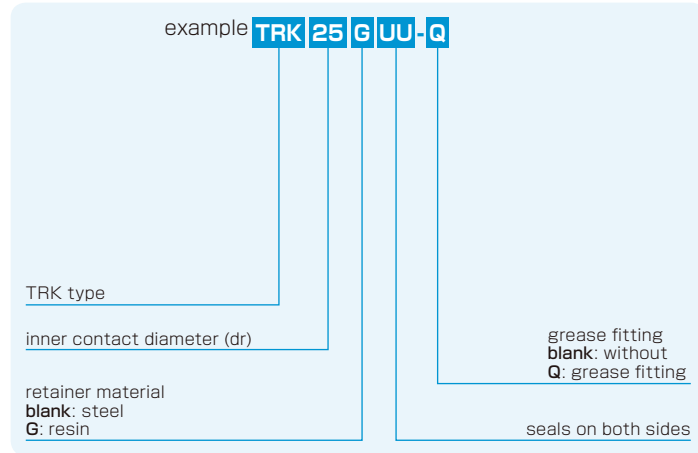

part number*		number of ball circuits	dr		major dimensions		
steel retainer	resin retainer		mm	tolerance μm	D mm	tolerance μm	L ± 0.3 mm
TRK 6UU	TRK 6GUU	4	6		15	0/-18	51
TRK 8UU	TRK 8GUU	4	8	0	19		66
TRK 10UU	TRK 10GUU	4	10	-12	23	0	80
TRK 12UU	TRK 12GUU	4	12		26	-21	84
TRK 13UU	TRK 13GUU	4	13	0	28		90
TRK 16UU	TRK 16GUU	4	16	-15	32	0	103
TRK 20UU	TRK 20GUU	5	20		40	-25	118
TRK 25UU	TRK 25GUU	6	25	0	45		165
TRK 30UU	TRK 30GUU	6	30	-18	52	0	182
TRK 35UU	TRK 35GUU	6	35		60	-30	200
TRK 40UU	TRK 40GUU	6	40	0	65		230
TRK 50UU	TRK 50GUU	6	50	-21	85	0	290
TRK 60UU	TRK 60GUU	6	60	0/-25	100	-35	310

* UU type is standard.

** Outer cylinder is treated with electroless nickel plating.

*** TRK6: A-MT6x1 TRK8: A-M6x1 TRK10~30: A-M6F TRK35~60: A-R1/8

Df mm	flange				grease fitting G mm	eccentricity μm	perpendicularity μm	basic load rating		allowable static moment $\text{N}\cdot\text{m}$	mass g	shaft diameter mm
	K mm	t mm	P.C.D. mm	X×Y×Z mm				C N	Co N			
32	25	5	24	3.5×6×3.1	20.5	20	20	323	530	8.2	58	6
40	30	6	29	4.5×7.5×4.1	29			431	784	16.0	117	8
43	34	6	33	4.5×7.5×4.1	38			588	1,100	27.0	189	10
46	35	6	36	4.5×7.5×4.1	41			813	1,570	40.1	228	12
48	37	6	38	4.5×7.5×4.1	45			813	1,570	42.9	286	13
54	42	8	43	5.5×9×5.1	51	25	25	1,230	2,350	73.5	376	16
62	50	8	51	5.5×9×5.1	59			1,400	2,740	98.0	714	20
74	58	10	60	6.6×11×6.1	82.5			1,560	3,140	157	1,163	25
82	64	10	67	6.6×11×6.1	91			2,490	5,490	297	1,543	30
96	75	13	78	9×14×8.1	100			2,650	6,270	373	2,400	35
101	80	13	83	9×14×8.1	115	30	30	3,430	8,040	553	2,510	40
129	100	18	107	11×17×11.1	145			6,080	15,900	1,370	6,400	50
144	116	18	122	11×17×11.1	155			7,550	20,000	1,800	9,200	60

1N≐0.102kgf 1N·m≐0.102kgf·m

TRFC TYPE

— Triple-Wide Intermediate Position Round Flange Type —

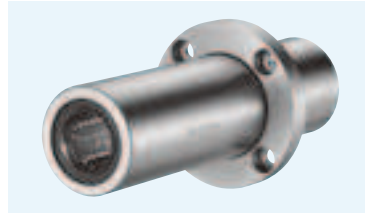

part number structure

example **TRFC 25 G UU-Q**

TRFC type

inner contact diameter (dr)

retainer material
blank: steel
G: resin

grease fitting
blank: without
Q: grease fitting

seals on both sides

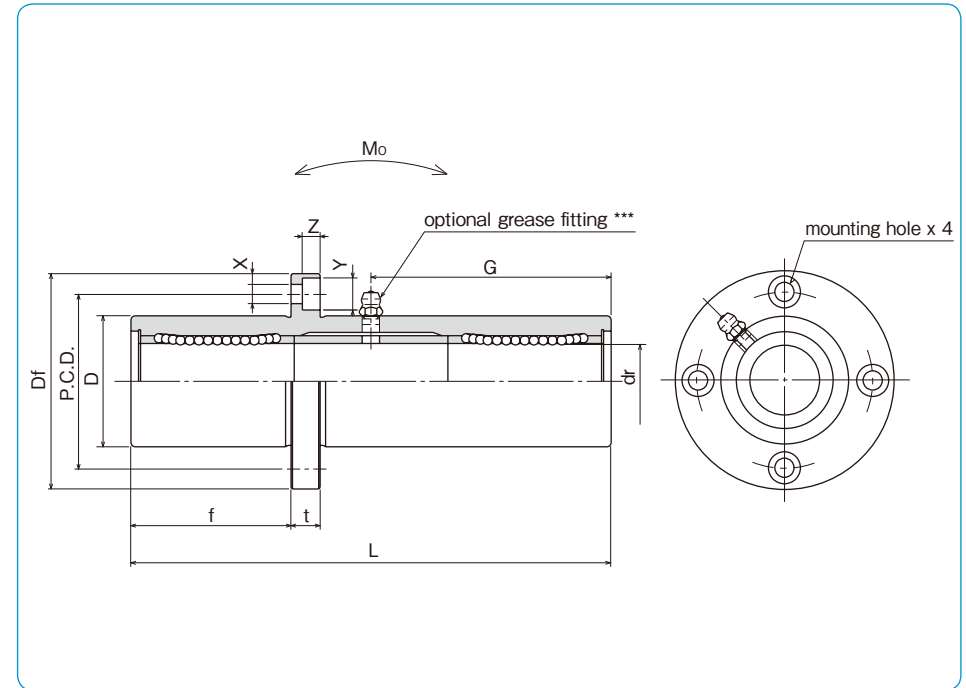

part number*		number of ball circuits	dr		major dimensions		
steel retainer	resin retainer		mm	tolerance μm	D mm	tolerance μm	L ± 0.3 mm
TRFC 6UU	TRFC 6GUU	4	6		15	0/-18	51
TRFC 8UU	TRFC 8GUU	4	8	0	19		66
TRFC 10UU	TRFC 10GUU	4	10	-12	23	0	80
TRFC 12UU	TRFC 12GUU	4	12		26	-21	84
TRFC 13UU	TRFC 13GUU	4	13	0	28		90
TRFC 16UU	TRFC 16GUU	4	16	-15	32		103
TRFC 20UU	TRFC 20GUU	5	20		40	0	118
TRFC 25UU	TRFC 25GUU	6	25	0	45	-25	165
TRFC 30UU	TRFC 30GUU	6	30	-18	52		182
TRFC 35UU	TRFC 35GUU	6	35		60	0	200
TRFC 40UU	TRFC 40GUU	6	40	0	65	-30	230
TRFC 50UU	TRFC 50GUU	6	50	-21	85	0	290
TRFC 60UU	TRFC 60GUU	6	60	0/-25	100	-35	310

* UU type is standard.

** Outer cylinder is treated with electroless nickel plating.

*** TRFC6: A-MT6x1 TRFC8: A-M6x1 TRFC10~30: A-M6F TRFC35~60: A-R1/8

f mm	Df mm	flange			grease fitting G mm	eccentricity μm	perpendicularity μm	basic load rating		allowable static moment $\text{N} \cdot \text{m}$	mass g	shaft diameter mm
		t mm	P.C.D. mm	X×Y×Z mm				dynamic C N	static Co N			
17	32	5	24	3.5×6×3.1	20.5	20	20	323	530	8.2	66	6
22	40	6	29	4.5×7.5×4.1	29			431	784	16.0	135	8
27	43	6	33	4.5×7.5×4.1	38			588	1,100	27.0	205	10
28	46	6	36	4.5×7.5×4.1	41			813	1,570	40.1	248	12
30	48	6	38	4.5×7.5×4.1	45			813	1,570	42.9	308	13
35	54	8	43	5.5×9×5.1	51			1,230	2,350	73.5	412	16
40	62	8	51	5.5×9×5.1	59	25	25	1,400	2,740	98.0	752	20
55	74	10	60	6.6×11×6.1	82.5			1,560	3,140	157	1,244	25
61	82	10	67	6.6×11×6.1	91			2,490	5,490	297	1,636	30
67	96	13	78	9×14×8.1	100			2,650	6,270	373	2,580	35
77	101	13	83	9×14×8.1	115			3,430	8,040	553	2,950	40
97	129	18	107	11×17×11.1	145			6,080	15,900	1,370	6,860	50
104	144	18	122	11×17×11.1	155	7,550	20,000	1,800	9,660	60		

1N≐0.102kgf 1N · m≐0.102kgf · m

TRKC TYPE

— Triple-Wide Intermediate Position Square Flange Type —

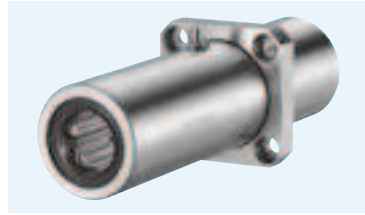

part number structure

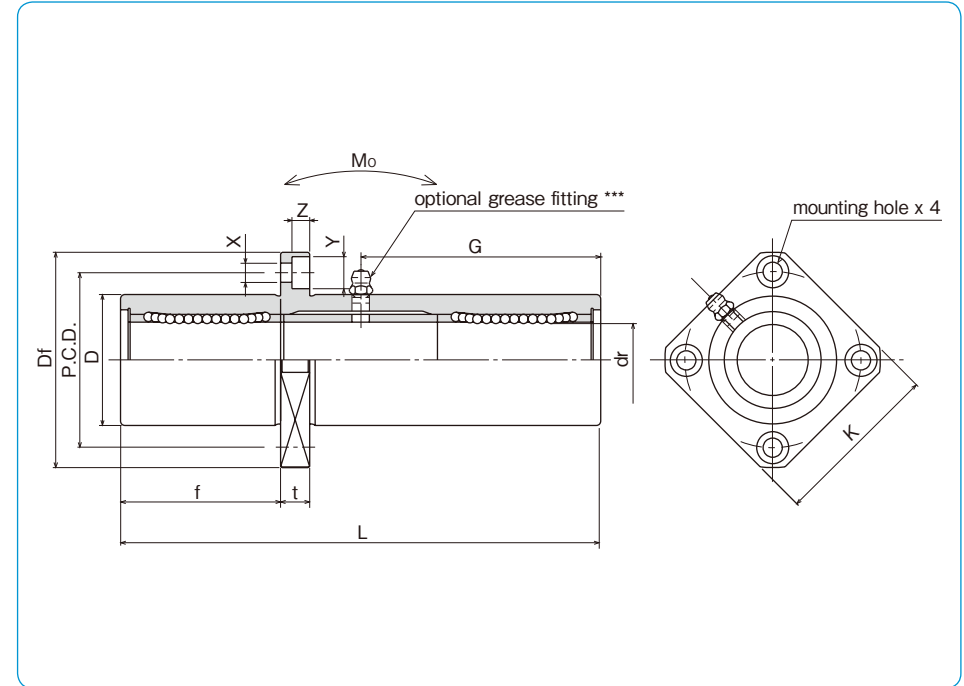
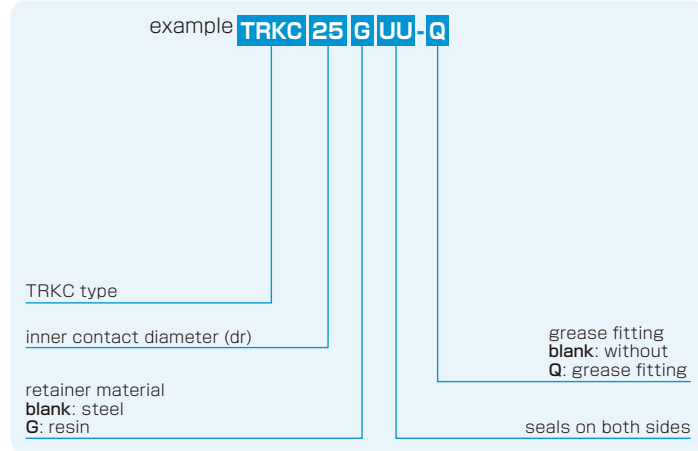

part number*		number of ball circuits	dr		major dimensions		
steel retainer	resin retainer		mm	tolerance μm	D mm	tolerance μm	L ± 0.3 mm
TRKC 6UU	TRKC 6GUU	4	6		15	0/-18	51
TRKC 8UU	TRKC 8GUU	4	8	0	19		66
TRKC 10UU	TRKC 10GUU	4	10	-12	23	0	80
TRKC 12UU	TRKC 12GUU	4	12		26	-21	84
TRKC 13UU	TRKC 13GUU	4	13	0	28		90
TRKC 16UU	TRKC 16GUU	4	16	-15	32	0	103
TRKC 20UU	TRKC 20GUU	5	20		40	-25	118
TRKC 25UU	TRKC 25GUU	6	25	0	45		165
TRKC 30UU	TRKC 30GUU	6	30	-18	52	0	182
TRKC 35UU	TRKC 35GUU	6	35		60	-30	200
TRKC 40UU	TRKC 40GUU	6	40	0	65		230
TRKC 50UU	TRKC 50GUU	6	50	-21	85	0	290
TRKC 60UU	TRKC 60GUU	6	60	0/-25	100	-35	310

* UU type is standard.

** Outer cylinder is treated with electroless nickel plating.

*** TRKC6: A-MT6x1 TRKC8: A-M6x1 TRKC10~30: A-M6F TRKC35~60: A-R1/8

f mm	Df mm	flange			P.C.D. mm	X×Y×Z mm	grease fitting G mm	eccentricity μm	perpendicularity μm	basic load rating		allowable static moment Mo N·m	mass g	shaft diameter mm
		K mm	t mm	C N						Co N				
17	32	25	5	24	3.5×6×3.1	20.5	20	20	323	530	8.2	58	6	
22	40	30	6	29	4.5×7.5×4.1	29			431	784	16.0	117	8	
27	43	34	6	33	4.5×7.5×4.1	38			588	1,100	27.0	189	10	
28	46	35	6	36	4.5×7.5×4.1	41			813	1,570	40.1	228	12	
30	48	37	6	38	4.5×7.5×4.1	45			813	1,570	42.9	286	13	
35	54	42	8	43	5.5×9×5.1	51	25	25	1,230	2,350	73.5	376	16	
40	62	50	8	51	5.5×9×5.1	59			1,400	2,740	98.0	714	20	
55	74	58	10	60	6.6×11×6.1	82.5			1,560	3,140	157	1,163	25	
61	82	64	10	67	6.6×11×6.1	91			2,490	5,490	297	1,543	30	
67	96	75	13	78	9×14×8.1	100			2,650	6,270	373	2,400	35	
77	101	80	13	83	9×14×8.1	115	30	30	3,430	8,040	553	2,510	40	
97	129	100	18	107	11×17×11.1	145			6,080	15,900	1,370	6,400	50	
104	144	116	18	122	11×17×11.1	155			7,550	20,000	1,800	9,200	60	

1N \approx 0.102kgf 1N·m \approx 0.102kgf·m

TRF-E TYPE

— Triple-Wide Round Flange Pilot End Type —

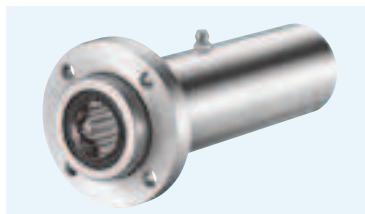

part number structure

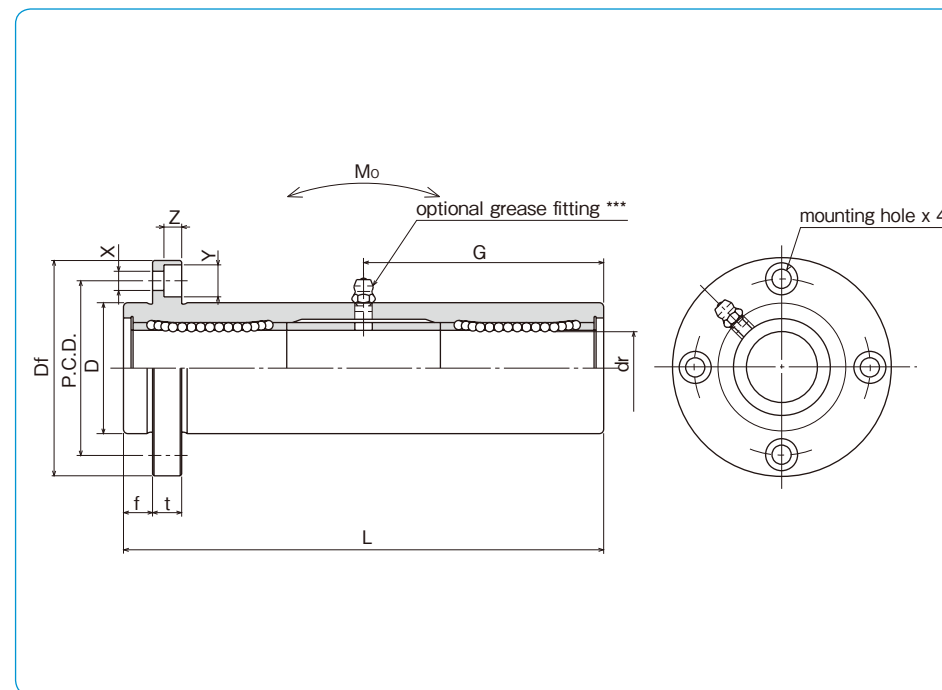
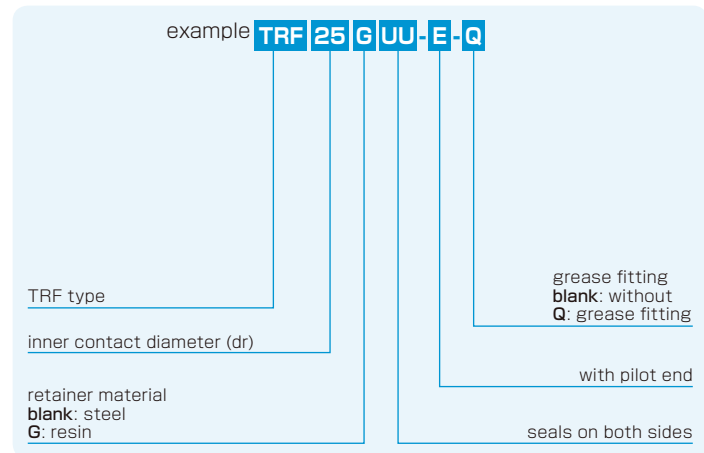

part number*		number of ball circuits	dr		major dimensions		
steel retainer	resin retainer		mm	tolerance μm	D	tolerance μm	L ± 0.3 mm
TRF 6UU-E	TRF 6GUU-E	4	6	0	15	0/-18	51
TRF 8UU-E	TRF 8GUU-E	4	8	-12	19		66
TRF10UU-E	TRF10GUU-E	4	10		23	0	80
TRF12UU-E	TRF12GUU-E	4	12		26	-21	84
TRF13UU-E	TRF13GUU-E	4	13	0	28		90
TRF16UU-E	TRF16GUU-E	4	16	-15	32		103
TRF20UU-E	TRF20GUU-E	5	20		40	0	118
TRF25UU-E	TRF25GUU-E	6	25	0	45	-25	165
TRF30UU-E	TRF30GUU-E	6	30	-18	52		182
TRF35UU-E	TRF35GUU-E	6	35		60	0	200
TRF40UU-E	TRF40GUU-E	6	40	0	65	-30	230
TRF50UU-E	TRF50GUU-E	6	50	-21	85	0	290
TRF60UU-E	TRF60GUU-E	6	60	0/-25	100	-35	310

* UU type is standard.

** Outer cylinder is treated with electroless nickel plating.

*** TRF6: A-MT6x1 TRF8: A-M6x1 TRF10~30: A-M6F TRF35~60: A-R1/8

f	Df	flange			grease fitting G	eccentricity	perpendicularity	basic load rating		allowable static moment Mo	mass	shaft diameter
		t	P.C.D.	X×Y×Z				dynamic C	static Co			
5	32	5	24	3.5×6×3.1	20.5	20	20	323	530	8.2	66	6
6	40	6	29	4.5×7.5×4.1	29			431	784	16.0	135	8
6	43	6	33	4.5×7.5×4.1	38			588	1,100	27.0	205	10
6	46	6	36	4.5×7.5×4.1	41			813	1,570	40.1	248	12
6	48	6	38	4.5×7.5×4.1	45			813	1,570	42.9	308	13
8	54	8	43	5.5×9×5.1	51			1,230	2,350	73.5	412	16
8	62	8	51	5.5×9×5.1	59	25	25	1,400	2,740	98.0	752	20
10	74	10	60	6.6×11×6.1	82.5			1,560	3,140	157	1,244	25
10	82	10	67	6.6×11×6.1	91			2,490	5,490	297	1,636	30
13	96	13	78	9×14×8.1	100			2,650	6,270	373	2,580	35
13	101	13	83	9×14×8.1	115			3,430	8,040	553	2,950	40
18	129	18	107	11×17×11.1	145			6,080	15,900	1,370	6,860	50
18	144	18	122	11×17×11.1	155	30	30	7,550	20,000	1,800	9,660	60

1N≐0.102kgf 1N·m≐0.102kgf·m

TRK-E TYPE

– Triple-Wide Square Flange Pilot End Type –

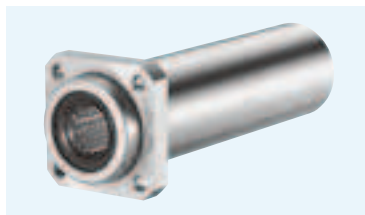

part number structure

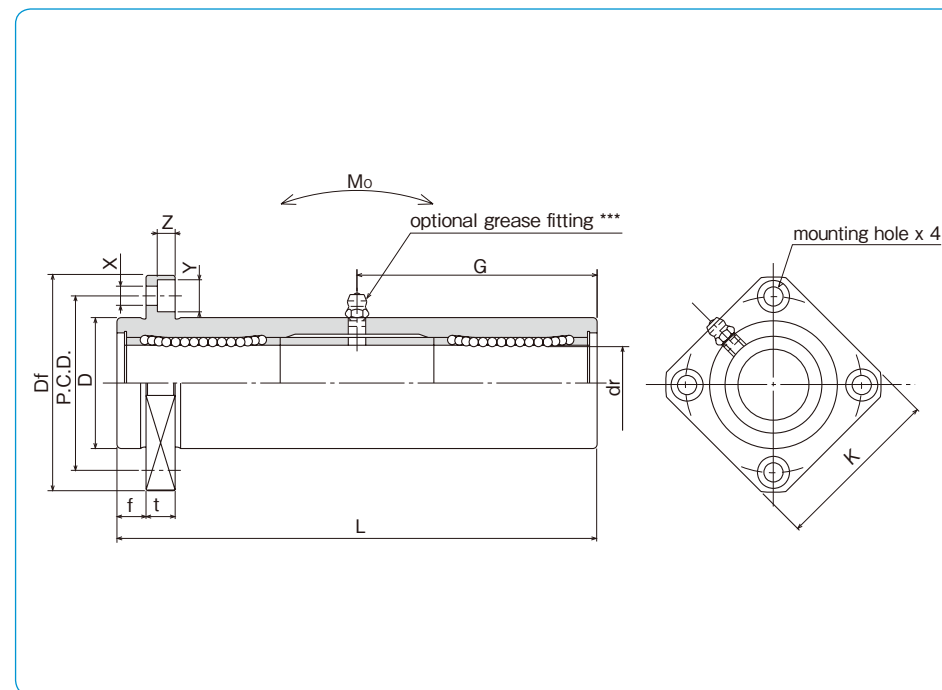
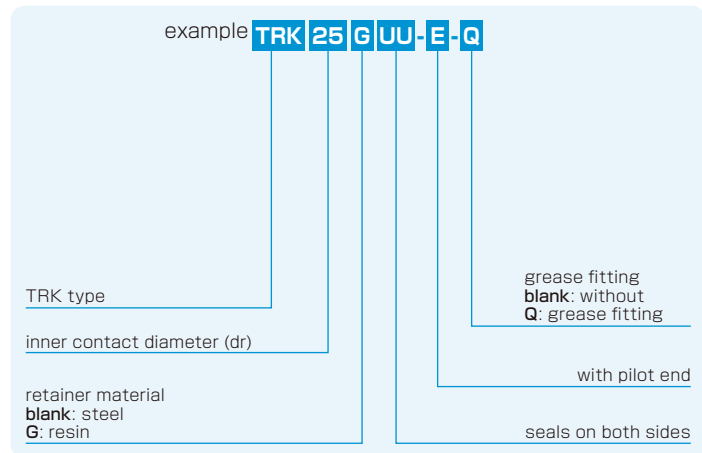

part number*		number of ball circuits	dr		major dimensions		
steel retainer	resin retainer		mm	tolerance μm	D mm	tolerance μm	L ± 0.3 mm
TRK 6UU-E	TRK 6GUU-E	4	6		15	0/-18	51
TRK 8UU-E	TRK 8GUU-E	4	8	0	19		66
TRK10UU-E	TRK10GUU-E	4	10	-12	23	0	80
TRK12UU-E	TRK12GUU-E	4	12		26	-21	84
TRK13UU-E	TRK13GUU-E	4	13	0	28		90
TRK16UU-E	TRK16GUU-E	4	16	-15	32		103
TRK20UU-E	TRK20GUU-E	5	20		40	0	118
TRK25UU-E	TRK25GUU-E	6	25	0	45	-25	165
TRK30UU-E	TRK30GUU-E	6	30	-18	52		182
TRK35UU-E	TRK35GUU-E	6	35		60	0	200
TRK40UU-E	TRK40GUU-E	6	40	0	65	-30	230
TRK50UU-E	TRK50GUU-E	6	50	-21	85	0	290
TRK60UU-E	TRK60GUU-E	6	60	0/-25	100	-35	310

* UU type is standard.

** Outer cylinder is treated with electroless nickel plating.

*** TRK6: A-MT6x1 TRK8: A-M6x1 TRK10~30: A-M6F TRK35~60: A-R1/8

f mm	Df mm	flange			P.C.D. mm	X×Y×Z mm	grease fitting G mm	eccentricity μm	perpendicularity μm	basic load rating		allowable static moment Mo N·m	mass g	shaft diameter mm
		K mm	t mm	C N						Co N				
5	32	25	5	24	3.5×6×3.1	20.5	20	20	323	530	8.2	58	6	
6	40	30	6	29	4.5×7.5×4.1	29			431	784	16.0	117	8	
6	43	34	6	33	4.5×7.5×4.1	38			588	1,100	27.0	189	10	
6	46	35	6	36	4.5×7.5×4.1	41	25	25	813	1,570	40.1	228	12	
6	48	37	6	38	4.5×7.5×4.1	45			813	1,570	42.9	286	13	
8	54	42	8	43	5.5×9×5.1	51			1,230	2,350	73.5	376	16	
8	62	50	8	51	5.5×9×5.1	59	30	30	1,400	2,740	98.0	714	20	
10	74	58	10	60	6.6×11×6.1	82.5			1,560	3,140	157	1,163	25	
10	82	64	10	67	6.6×11×6.1	91			2,490	5,490	297	1,543	30	
13	96	75	13	78	9×14×8.1	100	30	30	2,650	6,270	373	2,400	35	
13	101	80	13	83	9×14×8.1	115			3,430	8,040	553	2,510	40	
18	129	100	18	107	11×17×11.1	145			6,080	15,900	1,370	6,400	50	
18	144	116	18	122	11×17×11.1	155	7,550	20,000	1,800	9,200	60			

1N≐0.102kgf 1N·m≐0.102kgf·m

KB TYPE (Euro Standard)

– Standard Type –

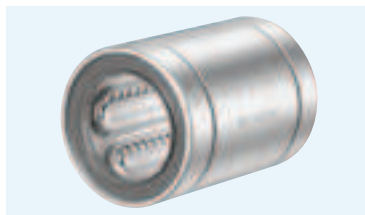

part number structure

example **KBS 25 G UU**

specification
KB: standard
KBS: anti-corrosion

inner contact diameter (dr)

retainer material
blank: standard/steel
 anti-corrosion/stainless steel
G: resin

seal
blank: without seal
U: seal on one side
UU: seals on both sides

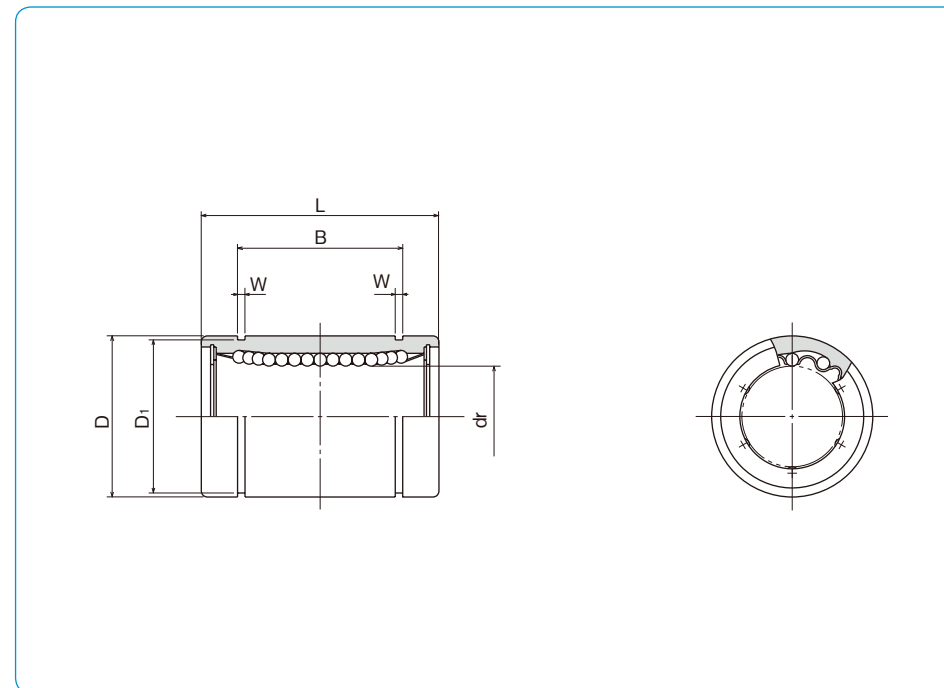

part number				number of ball circuits	dr		major dimensions	
standard steel retainer	resin retainer	anti-corrosion stainless retainer	resin retainer		mm	tolerance μm	mm	tolerance μm
KB 3	KB 3G	KBS 3	KBS 3G	4	3	+ 8 0	7	0 - 8
KB 4	KB 4G	KBS 4	KBS 4G	4	4		8	
KB 5	KB 5G	KBS 5	KBS 5G	4	5		12	
KB 8	KB 8G	KBS 8	KBS 8G	4	8		16	
KB10	KB10G	KBS10	KBS10G	4	10	+ 9 - 1	19	0 - 9
KB12	KB12G	KBS12	KBS12G	4	12		22	
KB16	KB16G	KBS16	KBS16G	4	16		26	
KB20	KB20G	KBS20	KBS20G	5	20		32	
KB25	KB25G	KBS25	KBS25G	6	25	+11	40	-11
KB30	KB30G	KBS30	KBS30G	6	30	- 1	47	
KB40	KB40G	KBS40	KBS40G	6	40	+13 - 2	62	0 -13
KB50	KB50G	KBS50	KBS50G	6	50		75	
KB60	KB60G	KBS60	KBS60G	6	60	+16/-4	90	0 -15
KB80	-	-	-	6	80		120	

mm	L	B		W	D ₁	eccentricity μm	radial clearance (maximum) μm	basic load rating		mass g	shaft diameter mm
	tolerance mm	mm	tolerance mm	mm	mm			dynamic C N	static Co N		
10	0	-	-	-	-	10	- 3	69	105	1.4	3
12	-0.12	-	-	-	-			88	127	2	4
22	0	14.5	-0.2	1.1	11.5			206	265	11	5
25		16.5		1.1	15.2	265	402	22	8		
29		22		1.3	18	372	549	36	10		
32		-0.2		22.9	1.3	21	510	784	45	12	
36	0	24.9	-0.3	1.3	24.9	12	- 4	578	892	60	16
45		31.5		1.6	30.3			862	1,370	102	20
58		44.1		1.85	37.5			980	1,570	235	25
68	0	52.1	0	1.85	44.5	15	- 6	1,570	2,740	360	30
80	-0.3	60.6	-0.3	2.15	59			2,160	4,020	770	40
100	0	77.6	0	2.65	72	17	-13	3,820	7,940	1,250	50
125		101.7		3.15	86.5			4,700	9,800	2,220	60
165		-0.4		133.7	-0.4			4.15	116	7,350	16,000

1N=0.102kgf

KB-AJ TYPE (Euro Standard)

– Clearance Adjustable Type –

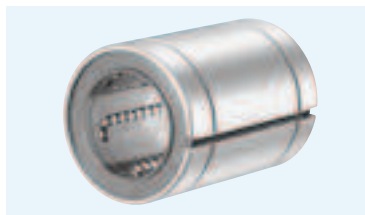

part number structure

example **KBS25GUU-AJ**

specification
KB: standard
KBS: anti-corrosion

inner contact diameter (dr)

retainer material
blank: standard/steel
 anti-corrosion/stainless steel
G: resin

seal
blank: without seal
U: seal on one side
UU: seals on both sides

clearance-adjustable

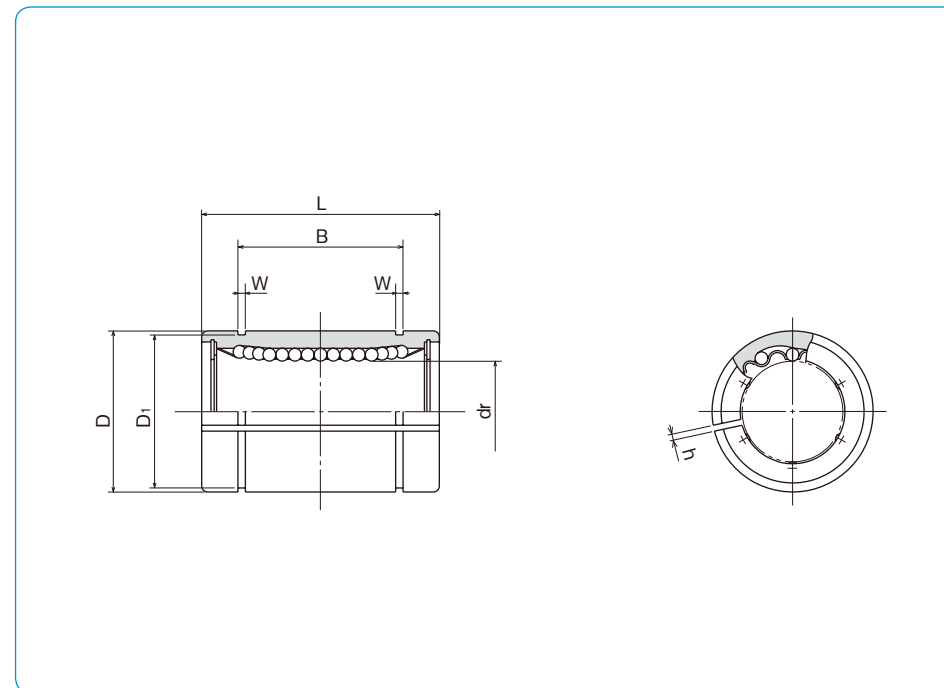

part number				number of ball circuits	dr mm	dr tolerance* μm	major dimensions	
standard steel retainer	resin retainer	anti-corrosion stainless retainer	resin retainer				D mm	D tolerance* μm
—	KB 5G-AJ	—	KBS 5G-AJ	4	5	0	12	0
—	KB 8G-AJ	—	KBS 8G-AJ	4	8	+ 8	16	- 8
—	KB10G-AJ	—	KBS10G-AJ	4	10	0	19	0
KB12-AJ	KB12G-AJ	KBS12-AJ	KBS12G-AJ	4	12	0	22	- 9
KB16-AJ	KB16G-AJ	KBS16-AJ	KBS16G-AJ	4	16	+ 9	26	0
KB20-AJ	KB20G-AJ	KBS20-AJ	KBS20G-AJ	5	20	- 1	32	0
KB25-AJ	KB25G-AJ	KBS25-AJ	KBS25G-AJ	6	25	+11	40	-11
KB30-AJ	KB30G-AJ	KBS30-AJ	KBS30G-AJ	6	30	- 1	47	0
KB40-AJ	KB40G-AJ	KBS40-AJ	KBS40G-AJ	6	40	+13	62	0
KB50-AJ	KB50G-AJ	KBS50-AJ	KBS50G-AJ	6	50	- 2	75	-13
KB60-AJ	KB60G-AJ	KBS60-AJ	KBS60G-AJ	6	60	0	90	0
KB80-AJ	—	—	—	6	80	+16/-4	120	-15

* Accuracy is measured prior to machining clearance slit.

mm	L	B		W mm	D ₁ mm	h mm	eccentricity* μm	basic load rating		mass g	shaft diameter mm
	tolerance mm	mm	tolerance mm					dynamic C N	static Co N		
22	0 -0.2	14.5	0 -0.2	1.1	11.5	1	12	206	265	10	5
25		16.5		1.1	15.2	1		265	402	19.5	8
29		22		1.3	18	1		372	549	29	10
32		22.9		1.3	21	1.5		510	784	44	12
36		24.9		1.3	24.9	1.5		578	892	59	16
45	0 -0.3	31.5	0 -0.3	1.6	30.3	2	15	862	1,370	100	20
58		44.1		1.85	37.5	2		980	1,570	230	25
68		52.1		1.85	44.5	2		1,570	2,740	355	30
80		60.6		2.15	59	3		2,160	4,020	758	40
100		77.6		2.65	72	3		3,820	7,940	1,230	50
125	0 -0.4	101.7	0 -0.4	3.15	86.5	3	20	4,700	9,800	2,170	60
165		133.7		4.15	116	3		7,350	16,000	5,000	80

1N=0.102kgf

KB-OP TYPE (Euro Standard)

– Open Type –

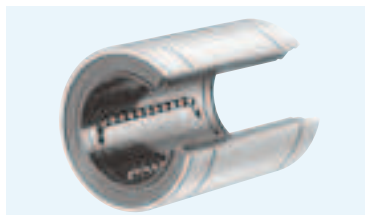

part number structure

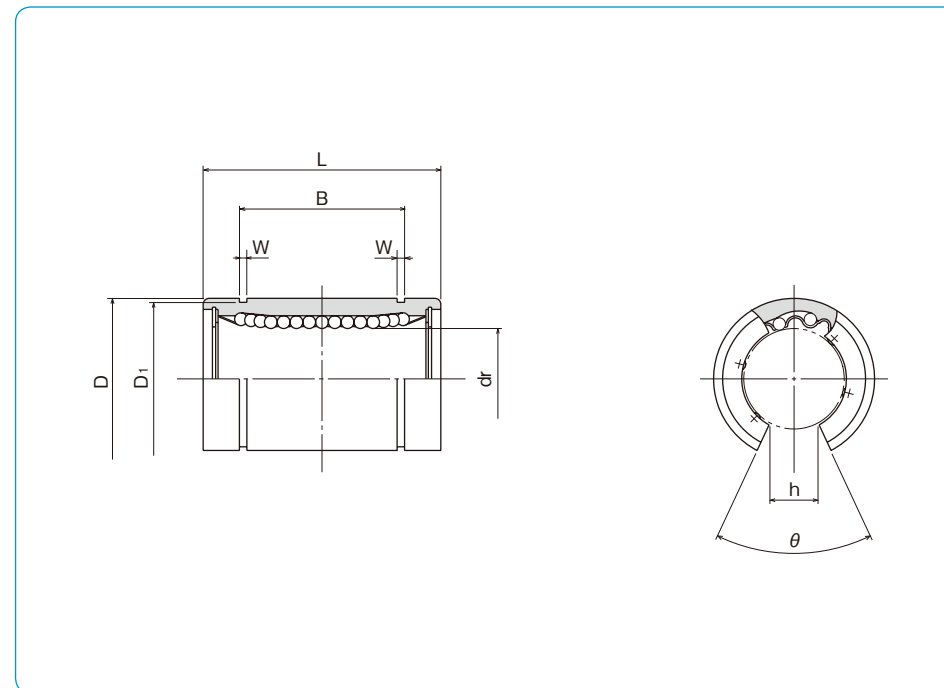
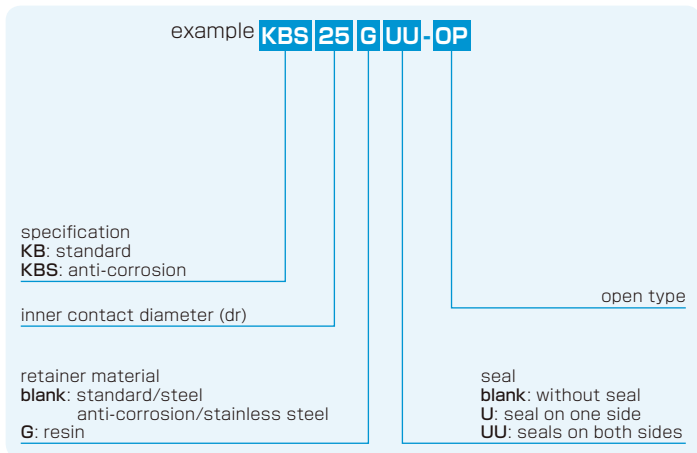

part number				number of ball circuits	dr		major dimensions	
standard steel retainer	resin retainer	anti-corrosion stainless retainer	resin retainer		mm	tolerance* μm	D mm	tolerance* μm
—	KB10G-OP	—	KBS10G-OP	3	10	+ 8	19	0
KB12-OP	KB12G-OP	KBS12-OP	KBS12G-OP	3	12	0	22	- 9
KB16-OP	KB16G-OP	KBS16-OP	KBS16G-OP	3	16	+ 9	26	0
KB20-OP	KB20G-OP	KBS20-OP	KBS20G-OP	4	20	- 1	32	-11
KB25-OP	KB25G-OP	KBS25-OP	KBS25G-OP	5	25	+11	40	0
KB30-OP	KB30G-OP	KBS30-OP	KBS30G-OP	5	30	- 1	47	-13
KB40-OP	KB40G-OP	KBS40-OP	KBS40G-OP	5	40	+ 13	62	0
KB50-OP	KB50G-OP	KBS50-OP	KBS50G-OP	5	50	- 2	75	-15
KB60-OP	KB60G-OP	KBS60-OP	KBS60G-OP	5	60		90	0
KB80-OP	—	—	—	5	80	+16/-4	120	-15

* Accuracy is measured prior to machining open slit.

mm	L tolerance mm	B tolerance mm		W mm	D ₁ mm	h mm	θ	eccentricity* μm	basic load rating		mass g	shaft diameter mm
		mm	mm						C N	Co N		
29	0 -0.2	22	0 -0.2	1.3	18	6.8	80°	12	372	549	23	10
32		22.9		1.3	21	7.5	78°		510	784	35	12
36		24.9		1.3	24.9	10	78°		578	892	48	16
45		31.5		1.6	30.3	10	60°		862	1,370	84	20
58	0 -0.3	44.1	0 -0.3	1.85	37.5	12.5	60°	15	980	1,570	195	25
68		52.1		1.85	44.5	12.5	50°		1,570	2,740	309	30
80		60.6		2.15	59	16.8	50°		2,160	4,020	665	40
100		77.6		2.65	72	21	50°		3,820	7,940	1,080	50
125	0 -0.4	101.7	0 -0.4	3.15	86.5	27.2	54°	20	4,700	9,800	1,900	60
165		133.7		4.15	116	36.3	54°		7,350	16,000	4,380	80

1N=0.102kgf

KB-W TYPE (Euro Standard)

– Double-Wide Type –

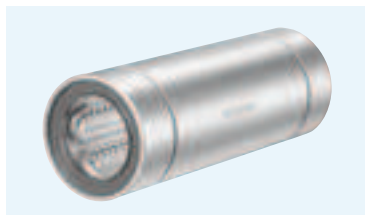

part number structure

example **KBS25GWUU**

specification
KB: standard
KBS: anti-corrosion

inner contact diameter (dr)

retainer material
blank: standard/steel
 anti-corrosion/stainless steel
G: resin

seal
blank: without seal
UU: seals on both sides

double-wide type

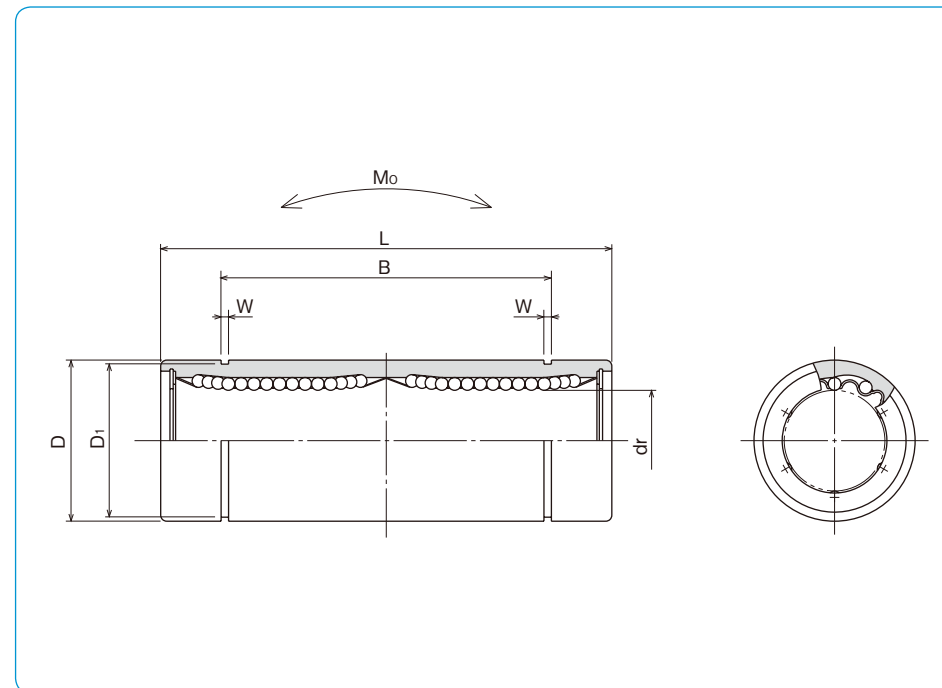

part number				number of ball circuits	dr		major dimensions	
standard steel retainer	resin retainer	anti-corrosion stainless retainer	resin retainer		mm	tolerance μm	D mm	tolerance μm
KB 8W	KB 8GW	KBS 8W	KBS 8GW	4	8	+ 9	16	0/-9
KB12W	KB12GW	KBS12W	KBS12GW	4	12	- 1	22	0
KB16W	KB16GW	KBS16W	KBS16GW	4	16	+ 11	26	-11
KB20W	KB20GW	KBS20W	KBS20GW	5	20	- 1	32	0
KB25W	KB25GW	KBS25W	KBS25GW	6	25	+ 13	40	-13
KB30W	KB30GW	KBS30W	KBS30GW	6	30	- 2	47	0
KB40W	KB40GW	KBS40W	KBS40GW	6	40	+ 16	62	0
KB50W	KB50GW	KBS50W	KBS50GW	6	50	- 4	75	-15
KB60W	KB60GW	KBS60W	KBS60GW	6	60		90	0/-20

mm	L tolerance mm	B tolerance mm	W mm	D1 mm	eccentricity μm	basic load rating		allowable static moment Mo N·m	mass g	shaft diameter mm
						dynamic C N	static Co N			
46		33	1.1	15.2	15	421	804	4.3	40	8
61	0	45.8	1.3	21		813	1,570	11.7	80	12
68	-0.3	49.8	1.3	24.9		921	1,780	14.2	115	16
80		61	1.6	30.5	17	1,370	2,740	25.0	180	20
112		82	1.85	38		1,570	3,140	44.0	430	25
123		104.2	1.85	44.5		2,500	5,490	78.9	615	30
151	0	121.2	2.15	59	20	3,430	8,040	147	1,400	40
192	-0.4	155.2	2.65	72		6,080	15,900	396	2,320	50
209		170	3.15	86.5		7,550	20,000	487	3,920	60

1N \approx 0.102kgf 1N·m \approx 0.102kgf·m

KBF TYPE (Euro Standard)

– Round Flange Type –

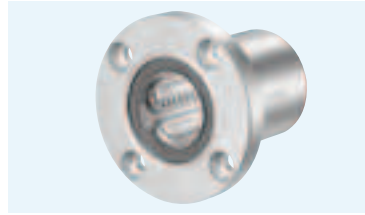

part number structure

example **KBSF 25 G UU-SK**

specification
KBF: standard
KBSF: anti-corrosion

inner contact diameter (dr)

retainer material
blank: standard/steel
 anti-corrosion/stainless steel
G: resin

outer cylinder surface treatment
blank: no surface treatment
SK: electroless nickel plating
LF: low temperature black chrome treatment with fluoride coating
SB: black oxide (not available on anti-corrosion type)
SC: industrial chrome plating

seal
blank: without seal
UU: seals on both sides

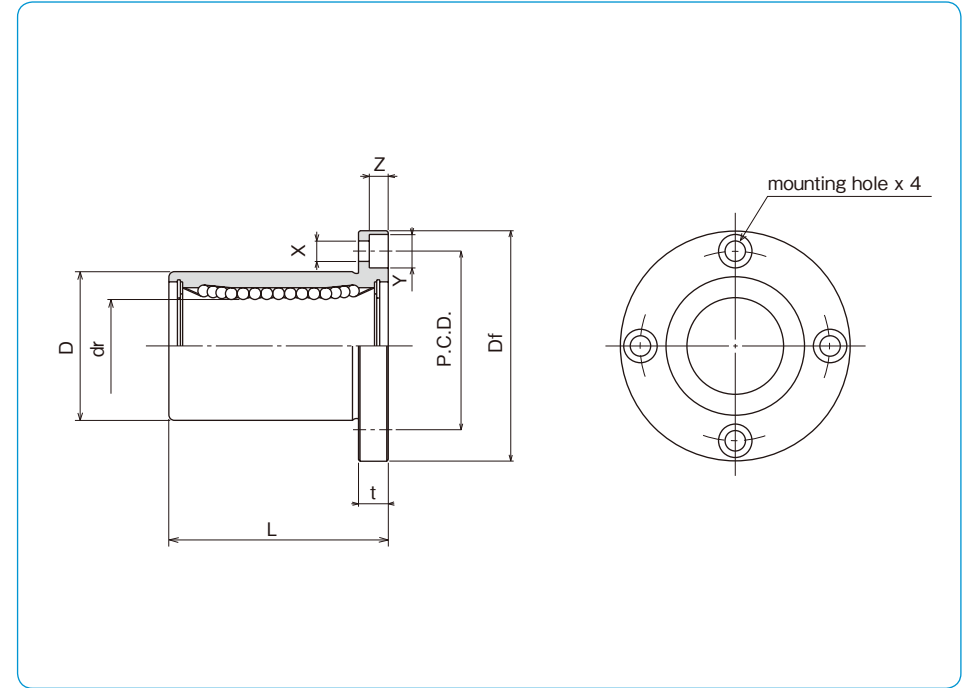

part number				number of ball circuits	dr		major dimensions		
standard steel retainer	resin retainer	anti-corrosion stainless retainer	resin retainer		mm	tolerance μm	D mm	tolerance μm	L ± 0.3 mm
—	KBF 5G	—	KBSF 5G	4	5		12	0	22
KBF 8	KBF 8G	KBSF 8	KBSF 8G	4	8	+ 8	16	-13	25
KBF12	KBF12G	KBSF12	KBSF12G	4	12	0	22	0	32
KBF16	KBF16G	KBSF16	KBSF16G	4	16	+ 9	26	-16	36
KBF20	KBF20G	KBSF20	KBSF20G	5	20	- 1	32	0	45
KBF25	KBF25G	KBSF25	KBSF25G	6	25	+11	40	0	58
KBF30	KBF30G	KBSF30	KBSF30G	6	30	- 1	47	-19	68
KBF40	KBF40G	KBSF40	KBSF40G	6	40		62	0	80
KBF50	KBF50G	KBSF50	KBSF50G	6	50	+13	75	-22	100
KBF60	KBF60G	KBSF60	KBSF60G	6	60	- 2	90	0	125
KBF80	—	—	—	6	80	+16/-4	120	-25	165

Df mm	t mm	flange P.C.D. mm	X×Y×Z mm	eccentricity μm	perpendicularity μm	basic load rating		mass g	shaft diameter mm
						dynamic C N	static Co N		
28	5	20	3.5×6×3.1	12	12	206	265	26	5
32	5	24	3.5×6×3.1			265	402	41	8
42	6	32	4.5×7.5×4.1			510	784	80	12
46	6	36	4.5×7.5×4.1			578	892	103	16
54	8	43	5.5×9×5.1			862	1,370	182	20
62	8	51	5.5×9×5.1	15	15	980	1,570	335	25
76	10	62	6.6×11×6.1			1,570	2,740	560	30
98	13	80	9×14×8.1			2,160	4,020	1,175	40
112	13	94	9×14×8.1	17	17	3,820	7,940	1,745	50
134	18	112	11×17×11.1			4,700	9,800	3,220	60
164	18	142	11×17×11.1	20	20	7,350	16,000	6,420	80

1N=0.102kgf

KBK TYPE (Euro Standard)

– Square Flange Type –

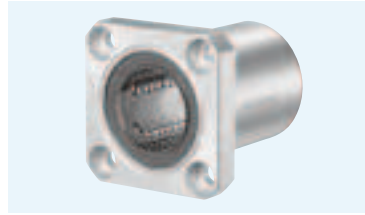

part number structure

example **KBSK 25 G UU-SK**

specification
KBK: standard
KBSK: anti-corrosion

inner contact diameter (dr)

retainer material
blank: standard/steel
 anti-corrosion/stainless steel
G: resin

outer cylinder surface treatment
blank: no surface treatment
SK: electroless nickel plating
LF: low temperature black chrome treatment with fluoride coating
SB: black oxide (not available on anti-corrosion type)
SC: industrial chrome plating

seal
blank: without seal
UU: seals on both sides

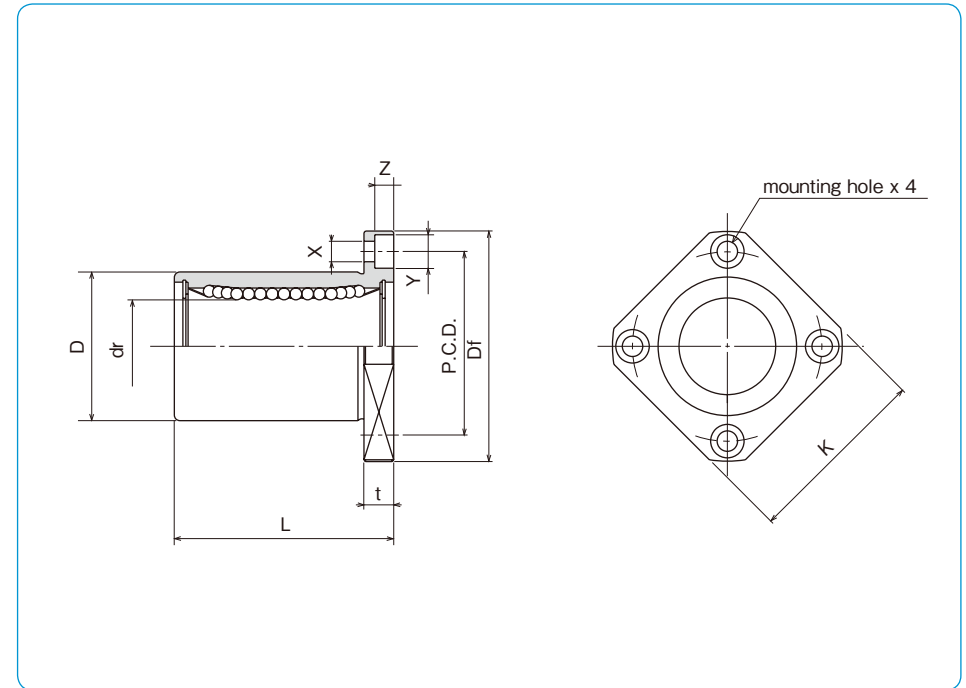

part number				number of ball circuits	dr		major dimensions		
standard steel retainer	resin retainer	anti-corrosion stainless retainer			mm	tolerance μm	D mm	tolerance μm	L ± 0.3 mm
—	KBK 5G	—	KBSK 5G	4	5		12	0	22
KBK 8	KBK 8G	KBSK 8	KBSK 8G	4	8	+ 8	16	-13	25
KBK12	KBK12G	KBSK12	KBSK12G	4	12	0	22	0	32
KBK16	KBK16G	KBSK16	KBSK16G	4	16	+ 9	26	-16	36
KBK20	KBK20G	KBSK20	KBSK20G	5	20	- 1	32	0	45
KBK25	KBK25G	KBSK25	KBSK25G	6	25	+11	40	0	58
KBK30	KBK30G	KBSK30	KBSK30G	6	30	- 1	47	-19	68
KBK40	KBK40G	KBSK40	KBSK40G	6	40		62	0	80
KBK50	KBK50G	KBSK50	KBSK50G	6	50	+13	75	-22	100
KBK60	KBK60G	KBSK60	KBSK60G	6	60	- 2	90	0	125
KBK80	—	—	—	6	80	+16/-4	120	-25	165

flange					eccentricity μm	perpendicularity μm	basic load rating		mass g	shaft diameter mm
Df mm	K mm	t mm	P.C.D. mm	X×Y×Z mm			dynamic C N	static Co N		
28	22	5	20	3.5×6×3.1	12	12	206	265	20	5
32	25	5	24	3.5×6×3.1			265	402	33	8
42	32	6	32	4.5×7.5×4.1			510	784	64	12
46	35	6	36	4.5×7.5×4.1			578	892	90	16
54	42	8	43	5.5×9×5.1			862	1,370	147	20
62	50	8	51	5.5×9×5.1	15	15	980	1,570	295	25
76	60	10	62	6.6×11×6.1			1,570	2,740	465	30
98	75	13	80	9×14×8.1			2,160	4,020	975	40
112	88	13	94	9×14×8.1	17	17	3,820	7,940	1,545	50
134	106	18	112	11×17×11.1			4,700	9,800	2,780	60
164	136	18	142	11×17×11.1	20	20	7,350	16,000	5,920	80

1N=0.102kgf

KBF-W TYPE (Euro Standard)

– Round Flange Double-Wide Type –

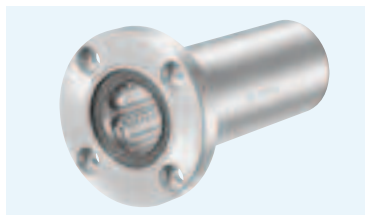

part number structure

example **KBSF 25 G W UU - SK**

specification
KBF: standard
KBSF: anti-corrosion

inner contact diameter (dr)

retainer material
blank: standard/steel
 anti-corrosion/stainless steel
G: resin

outer cylinder surface treatment
blank: no surface treatment
SK: electroless nickel plating
LF: low temperature black chrome treatment with fluoride coating
SB: black oxide (not available on anti-corrosion type)
SC: industrial chrome plating

seal
blank: without seal
UU: seals on both sides

double-wide type

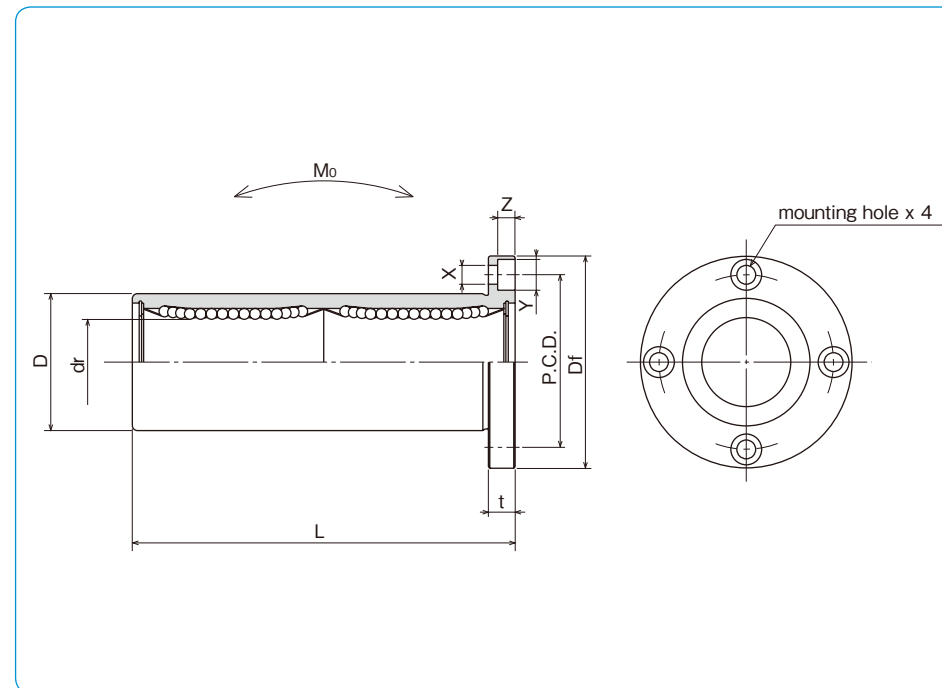

part number				number of ball circuits	dr		major dimensions		
standard steel retainer	resin retainer	anti-corrosion stainless retainer	resin retainer		mm	tolerance μm	D mm	tolerance μm	L ± 0.3 mm
KBF 8W	KBF 8GW	KBSF 8W	KBSF 8GW	4	8	+ 9	16	0/-13	46
KBF12W	KBF12GW	KBSF12W	KBSF12GW	4	12	- 1	22	0	61
KBF16W	KBF16GW	KBSF16W	KBSF16GW	4	16	+11	26	-16	68
KBF20W	KBF20GW	KBSF20W	KBSF20GW	5	20	- 1	32	0	80
KBF25W	KBF25GW	KBSF25W	KBSF25GW	6	25	+13	40	-19	112
KBF30W	KBF30GW	KBSF30W	KBSF30GW	6	30	- 2	47	0	123
KBF40W	KBF40GW	KBSF40W	KBSF40GW	6	40	+16	62	0	151
KBF50W	KBF50GW	KBSF50W	KBSF50GW	6	50	- 4	75	-22	192
KBF60W	KBF60GW	KBSF60W	KBSF60GW	6	60		90	0/-25	209

Df mm	t mm	flange P.C.D. mm	X×Y×Z mm	eccentricity μm	perpendicularity μm	basic load rating		allowable static moment $\text{N} \cdot \text{m}$	mass g	shaft diameter mm
						dynamic C N	static Co N			
32	5	24	3.5×6×3.1	15	15	421	804	4.3	59	8
42	6	32	4.5×7.5×4.1			813	1,570	11.7	110	12
46	6	36	4.5×7.5×4.1			921	1,780	14.2	160	16
54	8	43	5.5×9×5.1	17	17	1,370	2,740	25.0	260	20
62	8	51	5.5×9×5.1			1,570	3,140	44.0	540	25
76	10	62	6.6×11×6.1			2,500	5,490	78.9	815	30
98	13	80	9×14×8.1	20	20	3,430	8,040	147	1,805	40
112	13	94	9×14×8.1			6,080	15,900	396	2,820	50
134	18	112	11×17×11.1			7,550	20,000	487	4,920	60

1N \approx 0.102kgf 1N \cdot m \approx 0.102kgf \cdot m

KBK-W TYPE (Euro Standard)

– Square Flange Double-Wide Type –

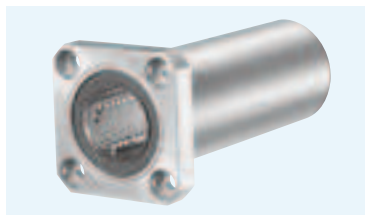

part number structure

example **KBK 25 G W UU - SK**

specification
KBK: standard
KBSK: anti-corrosion

inner contact diameter (dr)

retainer material
blank: standard/steel
 anti-corrosion/stainless steel
G: resin

outer cylinder surface treatment
blank: no surface treatment
SK: electroless nickel plating
LF: low temperature black chrome treatment with fluoride coating
SB: black oxide (not available on anti-corrosion type)
SC: industrial chrome plating

seal
blank: without seal
UU: seals on both sides

double-wide type

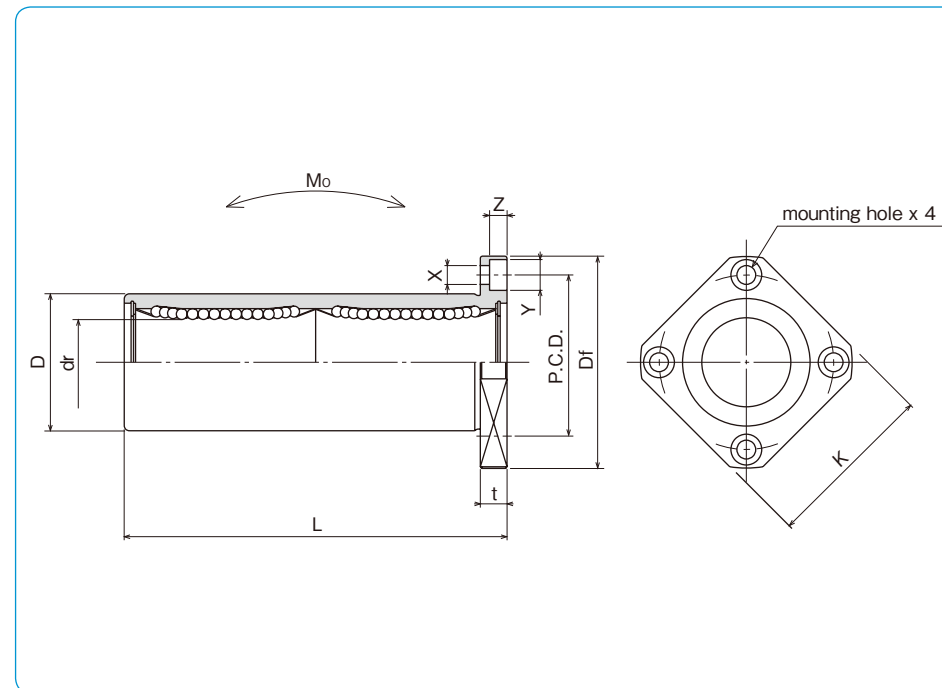

part number				number of ball circuits	dr		major dimensions		
standard steel retainer	resin retainer	anti-corrosion stainless retainer	resin retainer		mm	tolerance μm	D mm	tolerance μm	L ± 0.3 mm
KBK 8W	KBK 8GW	KBSK 8W	KBSK 8GW	4	8	+ 9	16	0/-13	46
KBK 12W	KBK 12GW	KBSK 12W	KBSK 12GW	4	12	- 1	22	0	61
KBK 16W	KBK 16GW	KBSK 16W	KBSK 16GW	4	16	+11	26	-16	68
KBK 20W	KBK 20GW	KBSK 20W	KBSK 20GW	5	20	- 1	32	0	80
KBK 25W	KBK 25GW	KBSK 25W	KBSK 25GW	6	25	+13	40	-19	112
KBK 30W	KBK 30GW	KBSK 30W	KBSK 30GW	6	30	- 2	47	0	123
KBK 40W	KBK 40GW	KBSK 40W	KBSK 40GW	6	40	+16	62	0	151
KBK 50W	KBK 50GW	KBSK 50W	KBSK 50GW	6	50	- 4	75	-22	192
KBK 60W	KBK 60GW	KBSK 60W	KBSK 60GW	6	60		90	0/-25	209

Df mm	K mm	flange			eccentricity μm	perpendicularity μm	basic load rating		allowable static moment Mo N·m	mass g	shaft diameter mm
		t mm	P.C.D. mm	X×Y×Z mm			dynamic C N	static Co N			
32	25	5	24	3.5×6×3.1	15	15	421	804	4.3	51	8
42	32	6	32	4.5×7.5×4.1			813	1,570	11.7	90	12
46	35	6	36	4.5×7.5×4.1			921	1,780	14.2	135	16
54	42	8	43	5.5×9×5.1	17	17	1,370	2,740	25.0	225	20
62	50	8	51	5.5×9×5.1			1,570	3,140	44.0	500	25
76	60	10	62	6.6×11×6.1			2,500	5,490	78.9	720	30
98	75	13	80	9×14×8.1	20	20	3,430	8,040	147	1,600	40
112	88	13	94	9×14×8.1			6,080	15,900	396	2,620	50
134	106	18	112	11×17×11.1			7,550	20,000	487	4,480	60

1N \approx 0.102kgf 1N · m \approx 0.102kgf · m

KBFC TYPE (Euro Standard)

– Center Mount Round Flange Type –

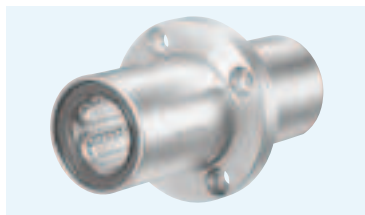

part number structure

example **KBSFC 25 G UU-SK**

specification KBFC: standard KBSFC: anti-corrosion	inner contact diameter (dr)	retainer material blank: standard/steel anti-corrosion/stainless steel G: resin	outer cylinder surface treatment blank: no surface treatment SK: electroless nickel plating LF: low temperature black chrome treatment with fluoride coating SB: black oxide (not available on anti-corrosion type) SC: industrial chrome plating	seal blank: without seal UU: seals on both sides
--	-----------------------------	--	--	--

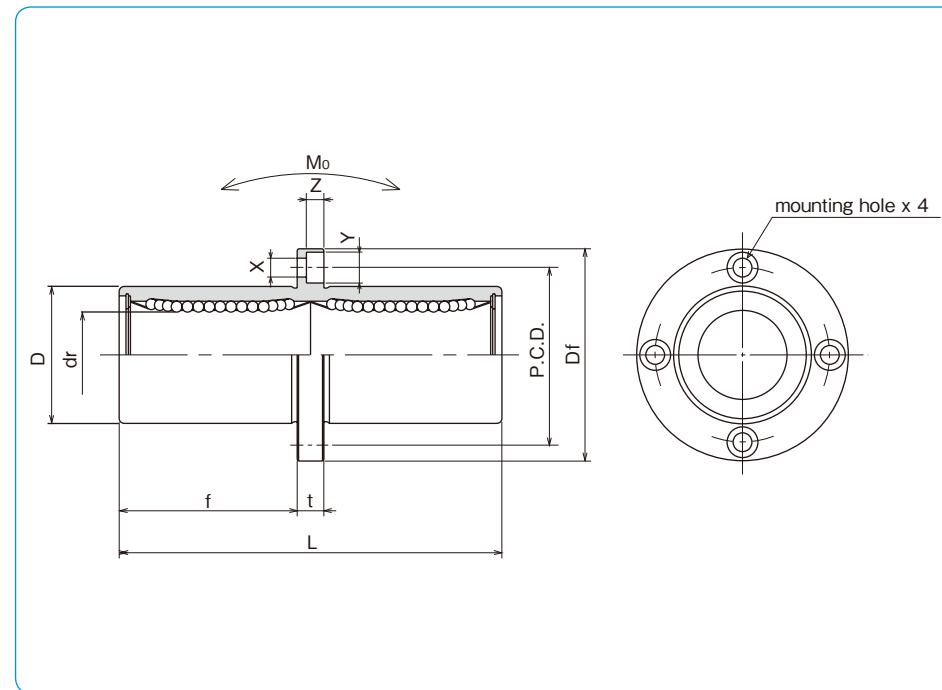

part number				number of ball circuits	dr		major dimensions		
standard steel retainer	resin retainer	anti-corrosion stainless retainer	resin retainer		mm	tolerance μm	D mm	tolerance μm	L ± 0.3 mm
KBFC 8	KBFC 8G	KBSFC 8	KBSFC 8G	4	8	+ 9	16	0/-13	46
KBFC12	KBFC12G	KBSFC12	KBSFC12G	4	12	- 1	22	0	61
KBFC16	KBFC16G	KBSFC16	KBSFC16G	4	16	+11	26	-16	68
KBFC20	KBFC20G	KBSFC20	KBSFC20G	5	20	- 1	32	0	80
KBFC25	KBFC25G	KBSFC25	KBSFC25G	6	25	+13	40	-19	112
KBFC30	KBFC30G	KBSFC30	KBSFC30G	6	30	- 2	47	0	123
KBFC40	KBFC40G	KBSFC40	KBSFC40G	6	40	+16	62	0	151
KBFC50	KBFC50G	KBSFC50	KBSFC50G	6	50	- 4	75	-22	192
KBFC60	KBFC60G	KBSFC60	KBSFC60G	6	60		90	0/-25	209

f mm	Df mm	t mm	flange P.C.D. mm	X×Y×Z mm	eccentricity μm	perpendicularity μm	basic load rating		allowable static moment $\text{N} \cdot \text{m}$	mass g	shaft diameter mm
							dynamic C N	static Co N			
20.5	32	5	24	3.5×6×3.1	15	15	421	804	4.3	59	8
27.5	42	6	32	4.5×7.5×4.1			813	1,570	11.7	110	12
31	46	6	36	4.5×7.5×4.1			921	1,780	14.2	160	16
36	54	8	43	5.5×9×5.1	17	17	1,370	2,740	25.0	260	20
52	62	8	51	5.5×9×5.1			1,570	3,140	44.0	540	25
56.5	76	10	62	6.6×11×6.1			2,500	5,490	78.9	815	30
69	98	13	80	9×14×8.1	20	20	3,430	8,040	147	1,805	40
89.5	112	13	94	9×14×8.1			6,080	15,900	396	2,820	50
95.5	134	18	112	11×17×11.1			7,550	20,000	487	4,920	60

1N \approx 0.102kgf 1N \cdot m \approx 0.102kgf \cdot m

KBKC TYPE (Euro Standard)

– Center Mount Square Flange Type –

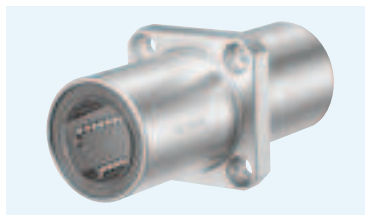

part number structure

example **KBSKC 25 G UU-SK**

specification KBKC: standard KBSKC: anti-corrosion	outer cylinder surface treatment blank: no surface treatment SK: electroless nickel plating LF: low temperature black chrome treatment with fluoride coating SB: black oxide (not available on anti-corrosion type) SC: industrial chrome plating
inner contact diameter (dr)	seal blank: without seal UU: seals on both sides
retainer material blank: standard/steel G: anti-corrosion/stainless steel G: resin	

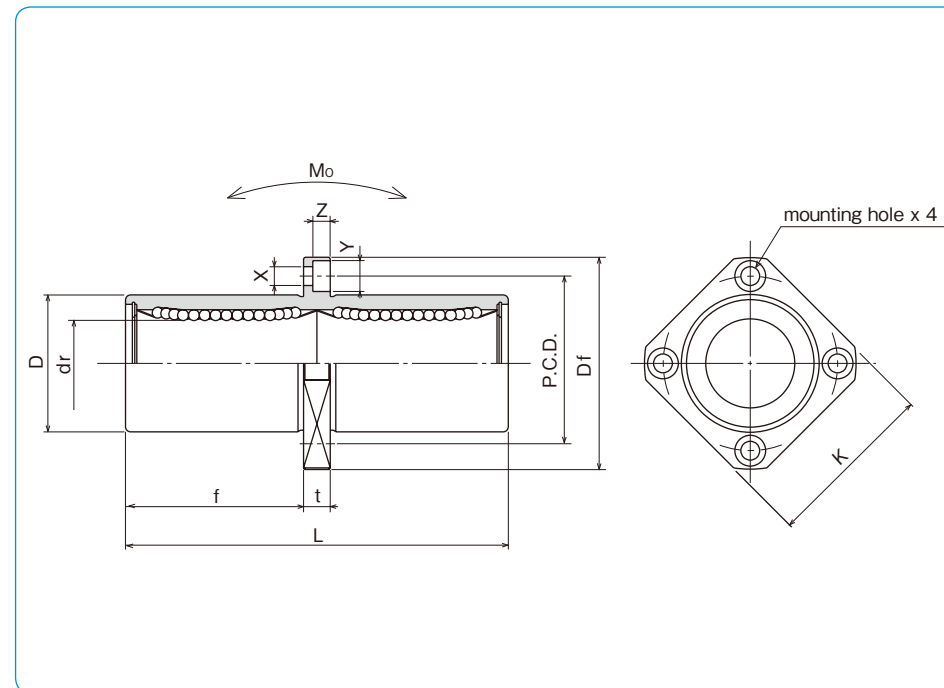

part number				number of ball circuits	dr		major dimensions		
standard steel retainer	resin retainer	anti-corrosion stainless retainer	resin retainer		mm	tolerance μm	D mm	tolerance μm	L ± 0.3 mm
KBKC 8	KBKC 8G	KBSKC 8	KBSKC 8G	4	8	+ 9	16	0/-13	46
KBKC 12	KBKC 12G	KBSKC 12	KBSKC 12G	4	12	- 1	22	0	61
KBKC 16	KBKC 16G	KBSKC 16	KBSKC 16G	4	16	+ 11	26	-16	68
KBKC 20	KBKC 20G	KBSKC 20	KBSKC 20G	5	20	- 1	32	0	80
KBKC 25	KBKC 25G	KBSKC 25	KBSKC 25G	6	25	+ 13	40	-19	112
KBKC 30	KBKC 30G	KBSKC 30	KBSKC 30G	6	30	- 2	47	-19	123
KBKC 40	KBKC 40G	KBSKC 40	KBSKC 40G	6	40	+ 16	62	0	151
KBKC 50	KBKC 50G	KBSKC 50	KBSKC 50G	6	50	- 4	75	-22	192
KBKC 60	KBKC 60G	KBSKC 60	KBSKC 60G	6	60	- 4	90	0/-25	209

flange						eccentricity μm	perpendicularity μm	basic load rating		allowable static moment $\text{N} \cdot \text{m}$	mass g	shaft diameter mm
f mm	Df mm	K mm	t mm	P.C.D. mm	X×Y×Z mm			dynamic C N	static Co N			
20.5	32	25	5	24	3.5×6×3.1	15	15	421	804	4.3	51	8
27.5	42	32	6	32	4.5×7.5×4.1			813	1,570	11.7	90	12
31	46	35	6	36	4.5×7.5×4.1			921	1,780	14.2	135	16
36	54	42	8	43	5.5×9×5.1	17	17	1,370	2,740	25.0	225	20
52	62	50	8	51	5.5×9×5.1			1,570	3,140	44.0	500	25
56.5	76	60	10	62	6.6×11×6.1			2,500	5,490	78.9	720	30
69	98	75	13	80	9×14×8.1	20	20	3,430	8,040	147	1,600	40
89.5	112	88	13	94	9×14×8.1			6,080	15,900	396	2,620	50
95.5	134	106	18	112	11×17×11.1			7,550	20,000	487	4,480	60

1N \approx 0.102kgf 1N \cdot m \approx 0.102kgf \cdot m

SW TYPE (Inch Standard)

— Standard Type —

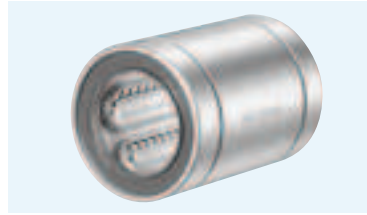

part number structure

example **SWS16GRUU-P**

specification
SW: standard
SWS: anti-corrosion

size

retainer material
blank: standard/steel
 anti-corrosion/stainless steel
G: resin

accuracy grade
blank: high
P: precision

seal
blank: without seal
U: seal on one side
UU: seals on both sides

*Seals are not available on SWS2 and SWS3.

self aligning
blank: non self aligning
R: self aligning

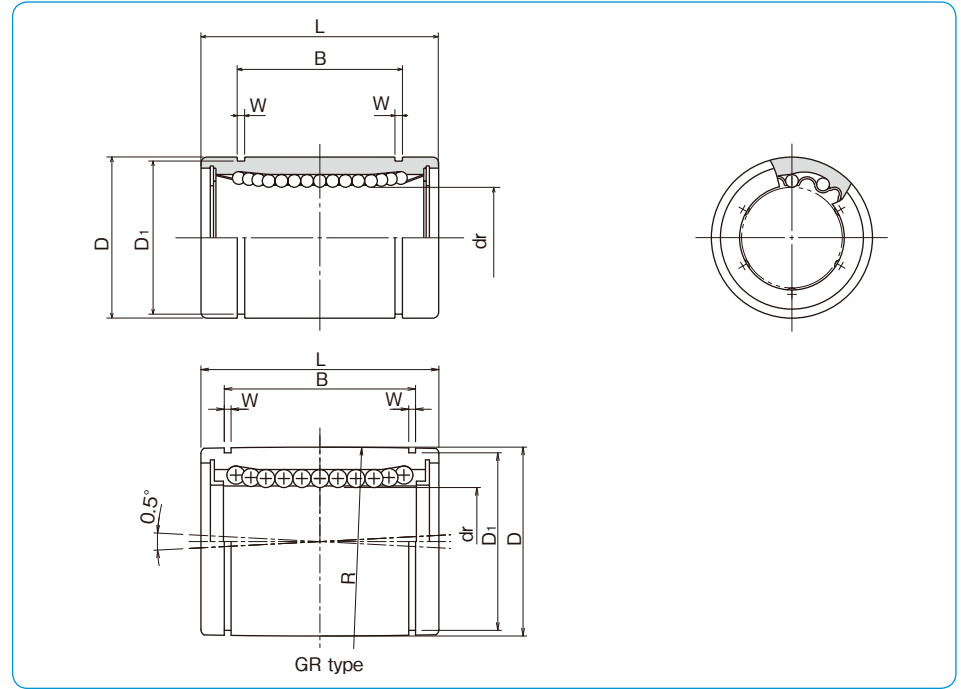

steel retainer	part number		anti-corrosion		number of ball circuits	dr		major dimensions	
	standard	resin retainer	stainless retainer	resin retainer		inch (mm)	tolerance precision	inch/(μm) high	inch (mm)
-	-	-	SWS2	SWS2G	4	.1250 (3.175)	-	0 -.00035 (-8)	.3125 (7.938) -.00040 (-9)
-	-	-	SWS3	SWS3G	4	.1875 (4.763)	-	0 -.00035 (-8)	.3750 (9.525) -.00040 (-9)
SW4	SW4G	SW4GR	SWS4	SWS4G	4	.2500 (6.350)	-	0 -.00025 (-6)	.5000 (12.700) -.00045 (-11) .6250 (15.875) 0
SW6	SW6G	SW6GR	SWS6	SWS6G	4	.3750 (9.525)	0 -.00025 (-6)	0 -.00040 (-9)	.8750 (22.225) 0 -.00050 (-13)
SW8	SW8G	SW8GR	SWS8	SWS8G	4	.5000 (12.700)	0 -.00025 (-6)	0 -.00040 (-9)	1.2500 (31.750) 0 -.00050 (-13)
SW10	SW10G	SW10GR	SWS10	SWS10G	4	.625 (15.875)	0 -.00025 (-6)	0 -.00040 (-9)	1.1250 (28.575) 0 -.00050 (-13)
SW12	SW12G	SW12GR	SWS12	SWS12G	5	.7500 (19.050)	0 -.00030 (-7)	0 -.00040 (-10)	1.2500 (31.750) 0 -.00065 (-16)
SW16	SW16G	SW16GR	SWS16	SWS16G	6	1.0000 (25.400)	0 -.00030 (-7)	0 -.00040 (-10)	1.5625 (39.688) 0 -.00075 (-19)
SW20	SW20G	SW20GR	SWS20	SWS20G	6	1.2500 (31.750)	0 -.00035 (-8)	0 -.00050 (-12)	2.0000 (50.800) 0 -.00075 (-19)
SW24	SW24G	SW24GR	SWS24	SWS24G	6	1.5000 (38.100)	0 -.00035 (-8)	0 -.00050 (-12)	2.3750 (60.325) 0 -.00075 (-19)
SW32	SW32G	SW32GR	SWS32	SWS32G	6	2.0000 (50.800)	0 -.00040 (-10)	0 -.00060 (-15)	3.0000 (76.200) 0 -.00090 (-22)
SW40	-	-	-	-	6	2.5000 (63.500)	0 -.00040 (-10)	0 -.00060 (-15)	3.7500 (95.250) 0 -.00090 (-22)
SW48	-	-	-	-	6	3.0000 (76.200)	0 -.00040 (-10)	0 -.00060 (-15)	4.5000 (114.300) 0 -.00100 (-25)
SW64	-	-	-	-	6	4.0000 (101.600)	0 -.00040 (-10)	0 -.00060 (-15)	6.0000 (152.400) 0 -.00100 (-25)

L	B	W	D ₁	eccentricity		radial clearance (maximum)	basic load rating		mass	shaft diameter
				precision	high		C	Co		
.5000 (12.700)	.3681 (9.35)	.0280 (0.710)	.2902 (7.370)	-	.0003 (8)	-.0001 (-2)	59	76	2.8	1/8 (3.175)
.5625 (14.275)	.4311 (10.95)	.0280 (0.710)	.3520 (8.940)	-	.0003 (8)	-.0001 (-2)	91	110	3.6	3/16 (4.763)
.7500 (19.050)	.5110 (12.98)	.0390 (0.992)	.4687 (11.906)	0	.0003 (8)	-.0001 (-3)	206	265	9.5	1/4 (6.350)
.8750 (22.225)	.6358 (16.15)	.0390 (0.992)	.5880 (14.935)	-0.008 (-0.2)	.0003 (8)	-.0001 (-3)	225	314	15	3/8 (9.525)
1.2500 (31.750)	.9625 (24.26)	.0459 (1.168)	.8209 (20.853)	-	.0003 (8)	-.0001 (-4)	510	784	42	1/2 (12.700)
1.5000 (38.100)	1.1039 (28.575)	.0559 (1.422)	1.0590 (26.899)	-	.0003 (8)	-.0001 (-4)	774	1,180	85	5/8 (15.875)
1.6250 (41.275)	1.1657 (29.61)	.0559 (1.422)	1.1760 (29.870)	-	.0004 (10)	-.0002 (-6)	862	1,370	104	3/4 (19.050)
2.2500 (57.150)	1.7547 (44.57)	.0679 (1.727)	1.4687 (37.306)	-	.0004 (10)	-.0002 (-6)	980	1,570	220	1 (25.400)
2.6250 (66.675)	2.0047 (50.92)	.0679 (1.727)	1.8859 (47.904)	0	.0005 (12)	-.0003 (-8)	1,570	2,740	465	1-1/4 (31.750)
3.0000 (76.200)	2.4118 (61.26)	.0859 (2.184)	2.2389 (56.870)	-0.012 (-0.3)	.0005 (12)	-.0003 (-8)	2,180	4,020	720	1-1/2 (38.100)
4.0000 (101.600)	3.1917 (81.07)	.1029 (2.616)	2.8379 (72.085)	-	.0007 (17)	-.0005 (-13)	3,820	7,940	1,310	2 (50.800)
5.0000 (127.000)	3.9760 (100.99)	.1200 (3.048)	3.5519 (90.220)	-	.0007 (17)	-.0005 (-13)	4,700	10,000	2,600	2-1/2 (63.500)
6.0000 (152.400)	4.726 (120.04)	.1200 (3.048)	4.3100 (109.474)	0	.0008 (20)	-.0008 (-20)	7,350	16,000	4,380	3 (76.200)
8.0000 (203.200)	6.258 (158.95)	.1389 (3.530)	5.745 (145.923)	-0.016 (-0.4)	.0008 (20)	-.0008 (-20)	14,100	34,800	10,200	4 (101.600)

SW-AJ TYPE (Inch Standard)

– Clearance Adjustable Type –

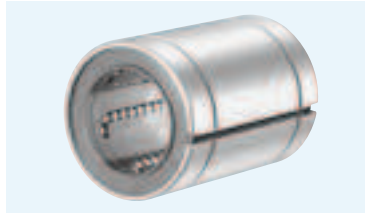

part number structure

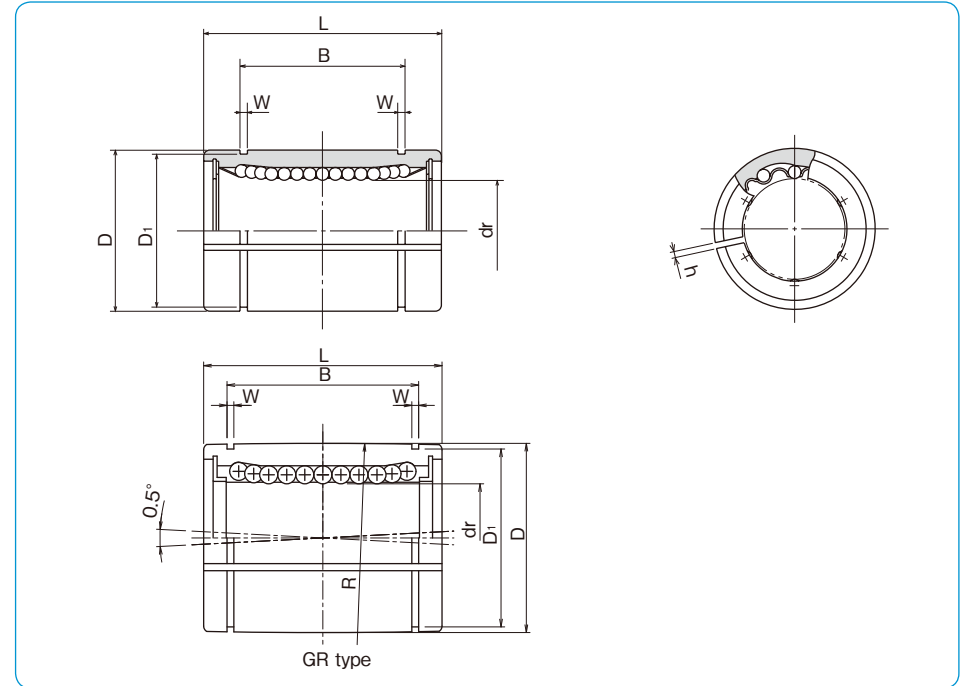
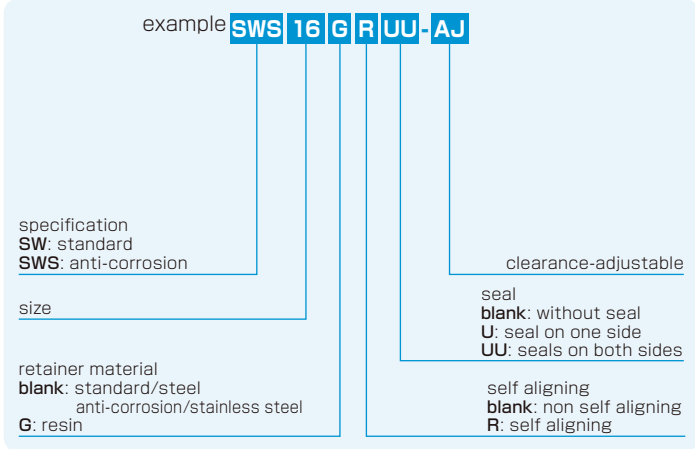

steel retainer	part number		number of ball circuits	major dimensions					
	standard resin retainer	anti-corrosion		dr		D			
		resin retainer		stainless retainer	inch (mm)	tolerance* inch/(μm)	inch (mm)	tolerance* inch/(μm)	
-	SW4G-AJ	-	-	SWS4G-AJ	4	.2500 (6.350)	0 (-11)	.5000 (12.700)	-.00045 (-11)
-	SW6G-AJ	-	-	SWS6G-AJ	4	.3750 (9.525)	0 (-9)	.6250 (15.875)	0
SW8-AJ	SW8G-AJ	SW8GR-AJ	SWS8-AJ	SWS8G-AJ	4	5.000 (12.700)	0 (-9)	.8750 (22.225)	-.00050 (-13)
SW10-AJ	SW10G-AJ	SW10GR-AJ	SWS10-AJ	SWS10G-AJ	4	.625 (15.875)	0	1.1250 (28.575)	0
SW12-AJ	SW12G-AJ	SW12GR-AJ	SWS12-AJ	SWS12G-AJ	5	.7500 (19.050)	0 (-10)	1.2500 (31.750)	-.00065 (-16)
SW16-AJ	SW16G-AJ	SW16GR-AJ	SWS16-AJ	SWS16G-AJ	6	1.0000 (25.400)	0	1.5625 (39.688)	0
SW20-AJ	SW20G-AJ	SW20GR-AJ	SWS20-AJ	SWS20G-AJ	6	1.2500 (31.750)	0	2.0000 (50.800)	-.00075 (-19)
SW24-AJ	SW24G-AJ	SW24GR-AJ	SWS24-AJ	SWS24G-AJ	6	1.5000 (38.100)	0 (-12)	2.3750 (60.325)	0
SW32-AJ	SW32G-AJ	SW32GR-AJ	SWS32-AJ	SWS32G-AJ	6	2.0000 (50.800)	0	3.0000 (76.200)	0
SW40-AJ	-	-	-	-	6	2.5000 (63.500)	0 (-15)	3.7500 (95.250)	-.00090 (-22)
SW48-AJ	-	-	-	-	6	3.0000 (76.200)	0	4.5000 (114.300)	0
SW64-AJ	-	-	-	-	6	4.0000 (101.600)	0 (-20)	6.0000 (152.400)	-.00100 (-25)

* Accuracy is measured prior to machining clearance slit.

inch (mm)	L tolerance inch/(mm)	B		W inch (mm)	D ₁ inch (mm)	h inch (mm)	eccentricity* inch (μm)	basic load rating		mass g	shaft diameter inch (mm)
		inch (mm)	tolerance inch/(mm)					dynamic C N	static Co N		
.7500 (19.050)	0	.5100 (12.98)	0	.0390 (0.992)	.4687 (11.906)	.04 (1)	.0005 (12)	206	265	7.5	1/4 (6.350)
.8750 (22.225)		.6358 (12.15)		.0390 (0.992)	.5880 (14.935)	.04 (1)		225	314	13.5	3/8 (9.525)
1.2500 (31.750)	-.008 (-0.2)	.9625 (24.46)	-.008 (-0.2)	.0459 (1.168)	.8209 (20.853)	.06 (1.5)	.0006 (15)	510	784	41	1/2 (12.700)
1.5000 (38.100)	0	1.1039 (28.04)	0	.0559 (1.422)	1.0590 (26.899)	.06 (1.5)		774	1,180	83	5/8 (15.875)
1.6250 (41.275)		0		1.1657 (29.61)	0	.0559 (1.422)	1.1760 (29.870)	.06 (1.5)	.0008 (20)	862	1,370
2.2500 (57.150)	0		1.7547 (44.57)	0		.0679 (1.727)	1.4687 (37.306)	.06 (1.5)		980	1,570
2.6250 (66.675)		0	2.0047 (50.92)		0	.0679 (1.727)	1.8859 (47.904)	.10 (2.5)	.0010 (25)	1,570	2,740
3.0000 (76.200)	-.012 (-0.3)		2.4118 (61.26)	-.012 (-0.3)		0.859 (2.184)	2.2389 (56.870)	.12 (3)		2,180	4,020
4.0000 (101.600)	0	3.1917 (81.07)	0	.1029 (2.616)	2.8379 (72.085)	.12 (3)	.0012 (30)	3,820	7,940	1,290	2 (50.800)
5.0000 (127.000)		0		3.9760 (100.99)	0	.1200 (3.048)		3.5519 (90.220)	.12 (3)	4,700	10,000
6.0000 (152.400)	0		4.726 (120.04)	0		.1200 (3.048)	4.3100 (109.474)	.12 (3)	.0012 (30)	7,350	16,000
8.0000 (203.200)		-.016 (-0.4)	6.258 (158.95)		-.016 (-0.4)	.1389 (3.530)	5.745 (145.923)	.12 (3)		14,100	34,800

1N ≅ 0.225lbf 1kg ≅ 2.205lbs

SW-OP TYPE (Inch Standard)

– Open Type –

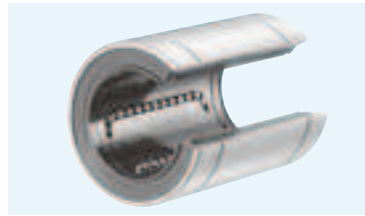

part number structure

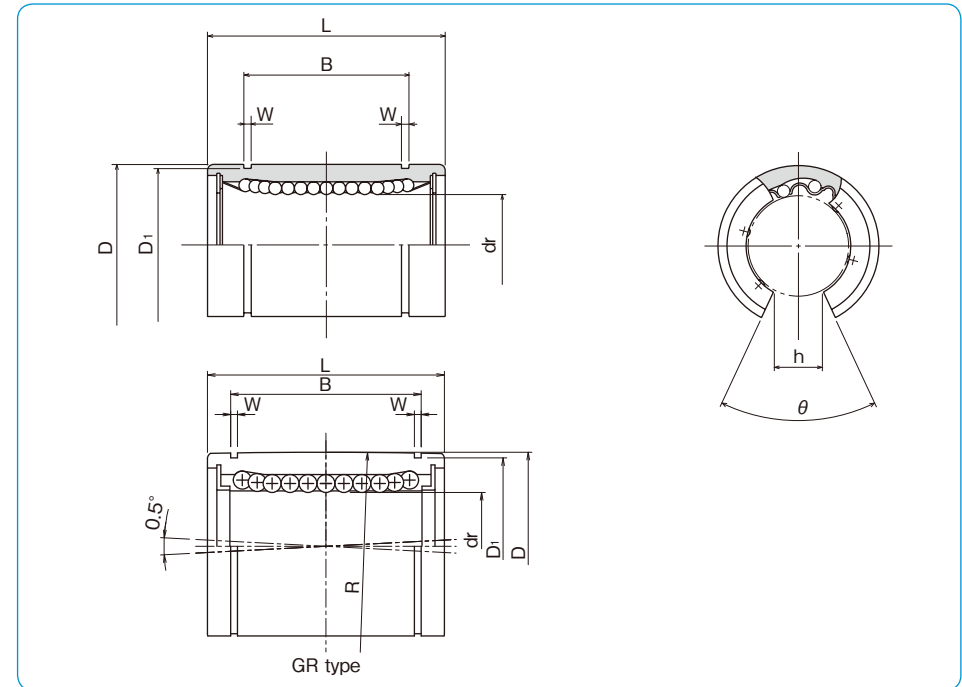
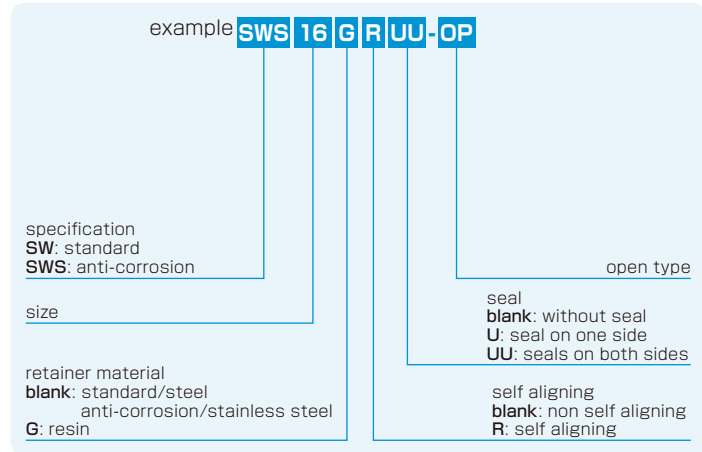

steel retainer	part number				number of ball circuits	major dimensions			
	standard		anti-corrosion			dr		D	
	resin retainer	steel retainer	resin retainer	steel retainer		inch (mm)	tolerance* inch/(μm)	inch (mm)	tolerance* inch/(μm)
SW 8-OP	SW 8G-OP	SW 8GR-OP	SWS 8-OP	SWS 8G-OP	3	.5000 (12.700)	0 -.00040 (-9)	.8750 (22.225)	0 -.00050 (-13)
SW10-OP	SW10G-OP	SW10GR-OP	SWS10-OP	SWS10G-OP	3	.625 (15.875)	0 -.00040 (-9)	1.1250 (28.575)	0 -.00050 (-13)
SW12-OP	SW12G-OP	SW12GR-OP	SWS12-OP	SWS12G-OP	4	.7500 (19.050)	0 -.00040 (-10)	1.2500 (31.750)	0 -.00065 (-16)
SW16-OP	SW16G-OP	SW16GR-OP	SWS16-OP	SWS16G-OP	5	1.0000 (25.400)	0 -.00040 (-10)	1.5625 (39.688)	0 -.00065 (-16)
SW20-OP	SW20G-OP	SW20GR-OP	SWS20-OP	SWS20G-OP	5	1.2500 (31.750)	0 -.00040 (-10)	2.0000 (50.800)	0 -.00075 (-19)
SW24-OP	SW24G-OP	SW24GR-OP	SWS24-OP	SWS24G-OP	5	1.5000 (38.100)	0 -.00050 (-12)	2.3750 (60.325)	0 -.00075 (-19)
SW32-OP	SW32G-OP	SW32GR-OP	SWS32-OP	SWS32G-OP	5	2.0000 (50.800)	0 -.00050 (-12)	3.0000 (76.200)	0 -.00090 (-22)
SW40-OP	-	-	-	-	5	2.5000 (63.500)	0 -.00060 (-15)	3.7500 (95.250)	0 -.00090 (-22)
SW48-OP	-	-	-	-	5	3.0000 (76.200)	0 -.00060 (-15)	4.5000 (114.300)	0 -.00090 (-22)
SW64-OP	-	-	-	-	5	4.0000 (101.600)	0 -.00080 (-20)	6.0000 (152.400)	0 -.00100 (-25)

* Accuracy is measured prior to machining clearance slit.

inch (mm)	L tolerance inch/(mm)	B		W inch (mm)	D1 inch (mm)	h inch (mm)	θ	eccentricity* inch (μm)	basic load rating		mass g	shaft diameter inch (mm)
		inch (mm)	tolerance inch/(mm)						dynamic C N	static Co N		
1.2500 (31.750)	0	.9625 (24.46)	0	.0459 (1.168)	.8209 (20.853)	.3125 (7.9375)	80°	.0005 (12)	510	784	32	1/2 (12.700)
1.5000 (38.100)	-.008 (-0.2)	1.1039 (28.04)	-.008 (-0.2)	.0559 (1.422)	1.0590 (26.899)	.375 (9.5250)	80°	.0005 (12)	774	1,180	64	5/8 (15.875)
1.6250 (41.275)	0	1.1657 (29.61)	0	.0559 (1.422)	1.1760 (29.870)	.4375 (11.1125)	60°	.0006 (15)	862	1,370	86	3/4 (19.050)
2.2500 (57.150)	0	1.7547 (44.57)	0	.0679 (1.727)	1.4687 (37.306)	.5625 (14.2875)	50°	.0006 (15)	980	1,570	190	1 (25.400)
2.6250 (66.675)	0	2.0047 (50.92)	0	.0679 (1.727)	1.8859 (47.904)	.625 (15.875)	50°	.0008 (20)	1,570	2,740	390	1-1/4 (31.750)
3.0000 (76.200)	-.012 (-0.3)	2.4118 (61.26)	-.012 (-0.3)	0.859 (2.184)	2.2389 (56.870)	.75 (19.05)	50°	.0010 (25)	2,180	4,020	610	1-1/2 (38.100)
4.0000 (101.600)	0	3.1917 (81.07)	0	.1029 (2.616)	2.8379 (72.085)	1.0 (25.40)	50°	.0010 (25)	3,820	7,940	1,120	2 (50.800)
5.0000 (127.000)	0	3.9760 (100.99)	0	.1200 (3.048)	3.5519 (90.220)	1.25 (31.75)	50°	.0010 (25)	4,700	10,000	2,230	2-1/2 (63.500)
6.0000 (152.400)	0	4.726 (120.04)	0	.1200 (3.048)	4.3100 (109.474)	1.5 (38.10)	50°	.0012 (30)	7,350	16,000	3,750	3 (76.200)
8.0000 (203.200)	-.016 (-0.4)	6.258 (158.95)	-.016 (-0.4)	.1389 (3.530)	5.745 (145.923)	2.0 (50.80)	50°	.0012 (30)	14,100	34,800	8,740	4 (101.60)

1N≅0.225lbf 1kg≅2.205lbs

SW-W TYPE (Inch Standard)

– Double-Wide Type –

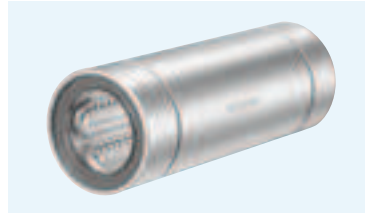

part number structure

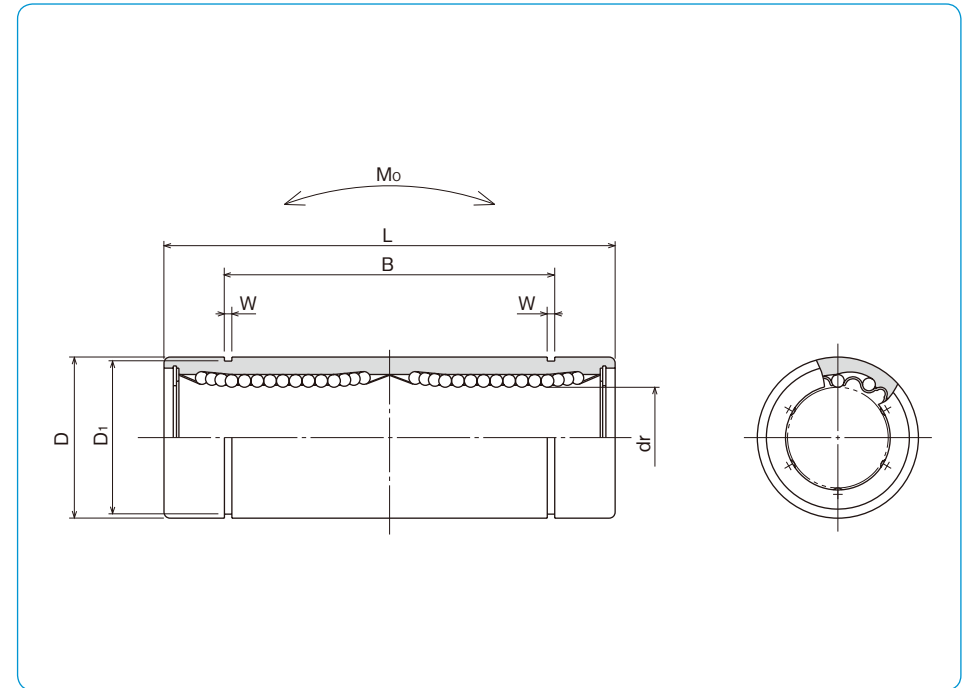
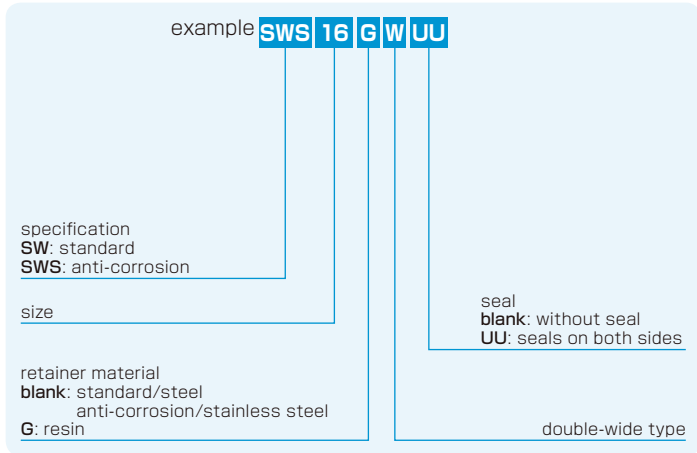

part number				number of ball circuits	dr		major dimensions	
standard		anti-corrosion			inch (mm)	tolerance inch/(μm)	D	
steel retainer	resin retainer	stainless retainer	resin retainer				inch (mm)	tolerance inch/(μm)
SW 4W	SW 4GW	SWS 4W	SWS 4GW	4	.2500 (6.350)	0 (-10)	.5000 (12.700)	0 (-13)
SW 6W	SW 6GW	SWS 6W	SWS 6GW	4	.3750 (9.525)		.6250 (15.875)	0
SW 8W	SW 8GW	SWS 8W	SWS 8GW	4	.5000 (12.700)	0 (-16)	.8750 (22.225)	-.00065 (-16)
SW10W	SW10GW	SWS10W	SWS10GW	4	.6250 (15.875)		1.1250 (28.575)	0
SW12W	SW12GW	SWS12W	SWS12GW	5	.7500 (19.050)	0 (-19)	1.2500 (31.750)	-.00075 (-19)
SW16W	SW16GW	SWS16W	SWS16GW	6	1.0000 (25.400)		1.5625 (39.688)	0
SW20W	SW20GW	SWS20W	SWS20GW	6	1.2500 (31.750)	0 (-22)	2.0000 (50.800)	-.00090 (-22)
SW24W	SW24GW	SWS24W	SWS24GW	6	1.5000 (38.100)		3.0000 (60.325)	0
SW32W	SW32GW	SWS32W	SWS32GW	6	2.0000 (50.800)	0 (-25)	3.0000 (76.200)	-.00100 (-25)

L		B		W	D ₁	eccentricity inch (μm)	basic load rating		allowable static moment Mo N·m	mass g	shaft diameter inch (mm)
inch (mm)	tolerance inch/(mm)	inch (mm)	tolerance inch/(mm)	inch (mm)	inch (mm)		dynamic C N	static Co N			
1.3750 (34.925)	0	1.0220 (25.959)	0	.0390 (0.992)	.4687 (11.906)	.0006 (15)	323	530	2.0	17.5	1/4 (6.350)
1.5938 (40.481)		1.2716 (32.298)		.0390 (0.992)	.5880 (14.935)		353	630	2.7	28	3/8 (9.525)
2.3750 (60.325)	-.012 (-0.3)	1.9250 (48.895)	-.012 (-0.3)	.0459 (1.168)	.8209 (20.853)	.0008 (20)	813	1,570	11.5	80	1/2 (12.700)
2.8125 (71.438)	0	2.2079 (56.080)	0	.0559 (1.422)	1.0590 (26.899)		1,230	2,350	20.0	160	5/8 (15.875)
3.0937 (78.581)		2.3314 (59.218)		.0559 (1.422)	1.1760 (29.870)	1,370	2,740	26.5	195	3/4 (19.050)	
4.2813 (108.744)	0	3.5094 (89.139)	0	.0679 (1.727)	1.4687 (37.306)	.0010 (25)	1,570	3,140	41.2	410	1 (25.400)
5.0000 (127.000)		4.0094 (101.839)		.0679 (1.727)	1.8859 (47.904)		2,500	5,490	84.8	820	1-1/4 (31.750)
5.6875 (144.463)	-.016 (-0.4)	4.8236 (122.519)	-.016 (-0.4)	.0859 (2.184)	2.2389 (56.870)	.0012 (30)	3,430	8,040	143	1,250	1-1/2 (38.100)
7.7500 (196.850)	0	6.3834 (162.138)	0	.1029 (2.616)	2.8379 (72.085)		6,080	15,900	399	2,350	2 (50.800)

1N≒0.225lbf 1N·m≒0.738lb·ft
 1kg≒2.205lbs

SWF TYPE (Inch Standard)

– Round Flange Type –

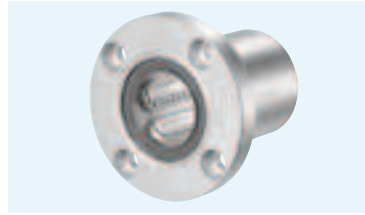

part number structure

example **SWSF 16 G UU-SK**

specification
SWF: standard
SWSF: anti-corrosion

size

retainer material
blank: standard/steel
 anti-corrosion/stainless steel
G: resin

outer cylinder
 surface treatment
blank: no surface treatment
SK: electroless nickel plating
LF: low temperature black chrome
 treatment with fluoride coating
SB: black oxide (not available on
 anti-corrosion type)
SC: industrial chrome plating

seal
blank: without seal
UU: seals on both sides

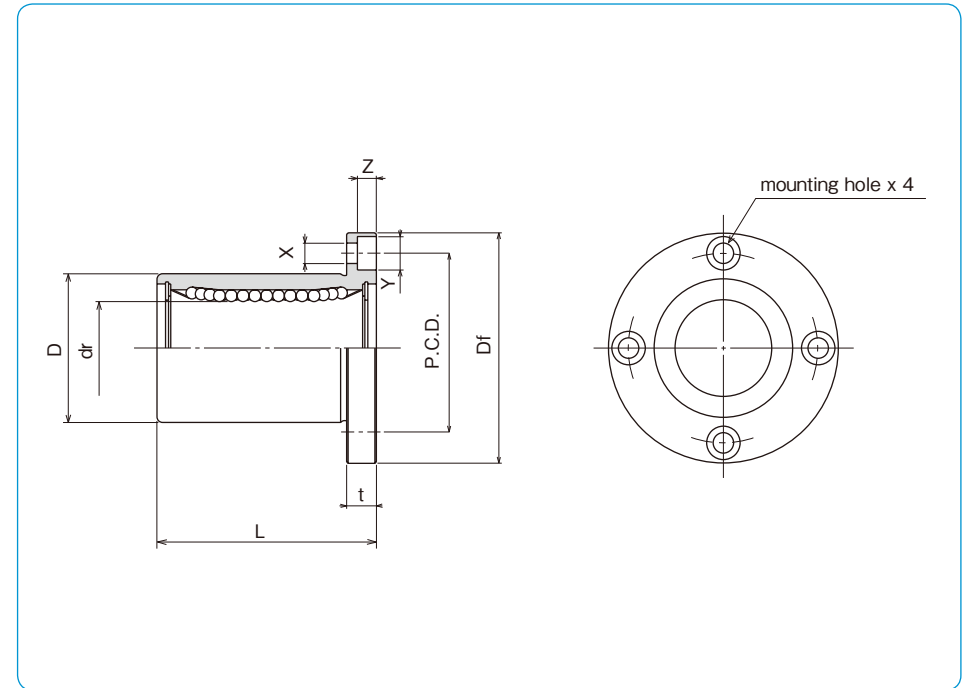

part number				number of ball circuits	major dimensions		
standard steel retainer	anti-corrosion resin retainer	stainless steel retainer	resin retainer		dr inch (mm) tolerance inch/(μm)	D inch (mm) tolerance inch/(μm)	L ±.012 (±0.3) inch/(mm)
SWF 4	SWF 4G	SWSF 4	SWSF 4G	4	.2500 (6.350)	.5000 (12.700)	⁰ / _{-.00050 (-13)} .7500 (19.050)
SWF 6	SWF 6G	SWSF 6	SWSF 6G	4	.3750 (9.525)	.6250 (15.875)	⁰ / _{-.00040 (-9)} .8750 (22.225)
SWF 8	SWF 8G	SWSF 8	SWSF 8G	4	.5000 (12.700)	.8750 (22.225)	⁰ / _{-.00065 (-16)} 1.2500 (31.750)
SWF10	SWF10G	SWSF10	SWSF10G	4	.6250 (15.875)	1.1250 (28.575)	⁰ / _{-.00075 (-19)} 1.5000 (38.100)
SWF12	SWF12G	SWSF12	SWSF12G	5	.7500 (19.050)	1.2500 (31.750)	⁰ / _{-.00090 (-22)} 1.6250 (41.275)
SWF16	SWF16G	SWSF16	SWSF16G	6	1.0000 (25.400)	1.5625 (39.688)	⁰ / _{-.00100 (-25)} 2.2500 (57.150)
SWF20	SWF20G	SWSF20	SWSF20G	6	1.2500 (31.750)	2.0000 (50.800)	⁰ / _{-.00115 (-29)} 2.6250 (66.675)
SWF24	SWF24G	SWSF24	SWSF24G	6	1.5000 (38.100)	2.3750 (60.325)	⁰ / _{-.00115 (-29)} 3.0000 (76.200)
SWF32	SWF32G	SWSF32	SWSF32G	6	2.0000 (50.800)	3.0000 (76.200)	⁰ / _{-.00115 (-29)} 4.0000 (101.600)
SWF40	–	–	–	6	2.5000 (63.500)	3.7500 (95.250)	⁰ / _{-.00115 (-29)} 5.0000 (127.000)
SWF48	–	–	–	6	3.0000 (76.200)	4.5000 (114.300)	⁰ / _{-.00115 (-29)} 6.0000 (152.400)
SWF64	–	–	–	6	4.0000 (101.600)	6.0000 (152.400)	⁰ / _{-.00115 (-29)} 8.0000 (203.200)

Df inch/(mm)	t inch/(mm)	flange		eccentricity inch (μm)	perpendicularity inch (μm)	basic load rating		mass g	shaft diameter inch (mm)
		P.C.D. inch/(mm)	X × Y × Z inch/(mm)			dynamic C N	static Co N		
1.2500 (31.750)	0.219 (5.556)	.8750 (22.225)	.1560 × 2.500 × .1410 (3.969 × 6.350 × 3.572)	.0005 (12)	.0005 (12)	206	265	32 (6.350)	
1.5000 (38.100)	.2500 (6.350)	1.0620 (26.988)	.1875 × 2.970 × .1720 (4.763 × 7.541 × 4.366)			225	314	47 (9.525)	
1.7500 (44.450)	.2500 (6.350)	1.312 (33.338)	.1875 × 2.970 × .1720 (4.763 × 7.541 × 4.366)			510	784	88 (12.700)	
2.0000 (50.800)	.2500 (6.350)	1.5620 (39.688)	.1875 × 2.970 × .1720 (4.763 × 7.541 × 4.366)			774	1,180	140 (15.875)	
2.1875 (55.563)	.3125 (7.938)	1.7180 (43.660)	.2187 × 3.440 × .2030 (5.556 × 8.731 × 5.159)	.0006 (15)	.0006 (15)	862	1,370	190 (19.050)	
2.5000 (63.500)	.3125 (7.938)	2.0310 (51.594)	.2187 × 3.440 × .2030 (5.556 × 8.731 × 5.159)			980	1,570	325 (25.400)	
3.1250 (79.375)	.3750 (9.525)	2.5625 (65.088)	.2812 × 4.060 × .2656 (7.144 × 10.319 × 6.747)			1,570	2,740	665 (31.750)	
3.7500 (95.250)	.5000 (12.700)	3.0625 (77.788)	.3440 × 5.000 × .3280 (8.731 × 12.700 × 8.334)	.0008 (20)	.0008 (20)	2,180	4,020	1,100 (38.100)	
4.3750 (111.125)	.5000 (12.700)	3.6875 (93.662)	.3440 × 5.000 × .3280 (8.731 × 12.700 × 8.334)			3,820	7,940	1,760 (50.800)	
5.3750 (136.525)	.7500 (19.050)	4.5625 (115.887)	.4062 × 6.250 × .3750 (10.319 × 15.875 × 9.525)			4,700	10,000	3,570 (63.500)	
6.1250 (155.575)	.7500 (19.050)	5.3125 (134.937)	.4062 × 6.250 × .3750 (10.319 × 15.875 × 9.525)			7,350	16,000	5,600 (76.200)	
8.0000 (203.200)	.8750 (22.225)	7.0000 (177.800)	.5000 × 7.125 × .5000 (12.700 × 18.097 × 12.700)	.0012 (30)	.0012 (30)	14,100	34,800	12,000 (101.600)	

1N ≅ 0.225lbf 1kg ≅ 2.205lbf

SWK TYPE (Inch Standard)

– Square Flange Type –

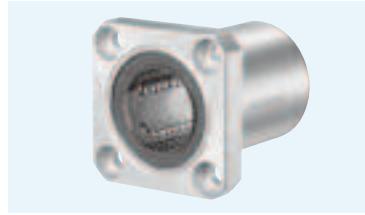

part number structure

example **SWSK 16 G UU-SK**

specification
SWK: standard
SWSK: anti-corrosion

size

retainer material
blank: standard/steel
 anti-corrosion/stainless steel
G: resin

outer cylinder
 surface treatment
blank: no surface treatment
SK: electroless nickel plating
LF: low temperature black chrome
 treatment with fluoride coating
SB: black oxide (not available on
 anti-corrosion type)
SC: industrial chrome plating

seal
blank: without seal
UU: seals on both sides

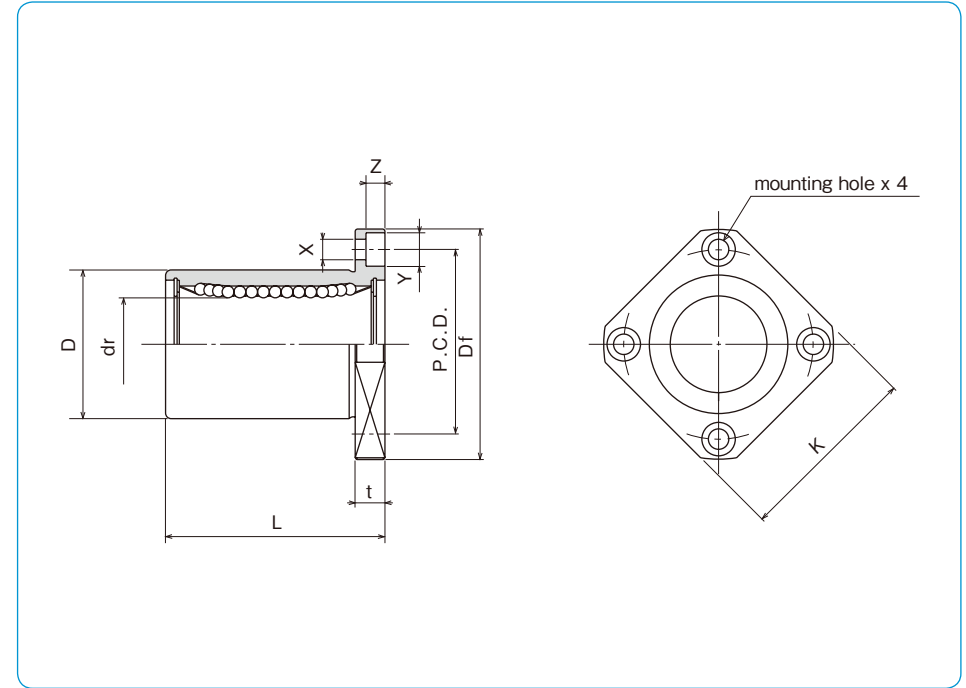

part number				number of ball circuits	major dimensions		
standard steel retainer	anti-corrosion resin retainer	stainless steel retainer	resin retainer		dr inch (mm) tolerance inch/(μm)	D inch (mm) tolerance inch/(μm)	L ±.012 (±0.3) inch/(mm)
SWK 4	SWK 4G	SWSK 4	SWSK 4G	4	.2500 (6.350)	.5000 (12.700)	.7500 (19.050)
SWK 6	SWK 6G	SWSK 6	SWSK 6G	4	.3750 (9.525)	.6250 (15.875)	.8750 (22.225)
SWK 8	SWK 8G	SWSK 8	SWSK 8G	4	.5000 (12.700)	.8750 (22.225)	1.2500 (31.750)
SWK10	SWK10G	SWSK10	SWSK10G	4	.6250 (15.875)	1.1250 (28.575)	1.5000 (38.100)
SWK12	SWK12G	SWSK12	SWSK12G	5	.7500 (19.050)	1.2500 (31.750)	1.6250 (41.275)
SWK16	SWK16G	SWSK16	SWSK16G	6	1.0000 (25.400)	1.5625 (39.688)	2.2500 (57.150)
SWK20	SWK20G	SWSK20	SWSK20G	6	1.2500 (31.750)	2.0000 (50.800)	2.6250 (66.675)
SWK24	SWK24G	SWSK24	SWSK24G	6	1.5000 (38.100)	2.3750 (60.325)	3.0000 (76.200)
SWK32	SWK32G	SWSK32	SWSK32G	6	2.0000 (50.800)	3.0000 (76.200)	4.0000 (101.600)
SWK40	–	–	–	6	2.5000 (63.500)	3.7500 (95.250)	5.0000 (127.000)
SWK48	–	–	–	6	3.0000 (76.200)	4.5000 (114.300)	6.0000 (152.400)
SWK64	–	–	–	6	4.0000 (101.600)	6.0000 (152.400)	8.0000 (203.200)

flange					eccentricity inch (μm)	perpendicularity inch (μm)	basic load rating		mass g	shaft diameter inch (mm)
Df inch (mm)	K inch (mm)	t inch (mm)	P.C.D. inch (mm)	X × Y × Z inch (mm)			dynamic C N	static Co N		
1.2500 (31.750)	1.0000 (25.400)	0.219 (5.556)	.8750 (22.225)	.1560 x .2500 x .1410 (3.969 x 6.350 x 3.572)	.0005 (12)	.0005 (12)	206	265	25 (6.350)	
1.5000 (38.100)	1.2500 (31.750)	.2500 (6.350)	1.0620 (26.988)	.1875 x .2970 x .1720 (4.763 x 7.541 x 4.366)			225	314	32 (9.525)	
1.7500 (44.450)	1.3750 (34.925)	.2500 (6.350)	1.312 (33.338)	.1875 x .2970 x .1720 (4.763 x 7.541 x 4.366)			510	784	68 (12.700)	
2.0000 (50.800)	1.5000 (38.100)	.2500 (6.350)	1.5620 (39.688)	.1875 x .2970 x .1720 (4.763 x 7.541 x 4.366)			774	1,180	124 (15.875)	
2.1875 (55.563)	1.6875 (42.863)	.3125 (7.938)	1.7180 (43.660)	.2187 x .3440 x .2030 (5.556 x 8.731 x 5.159)	.0006 (15)	.0006 (15)	862	1,370	150 (19.050)	
2.5000 (63.500)	2.0000 (50.800)	.3125 (7.938)	2.0310 (51.594)	.2187 x .3440 x .2030 (5.556 x 8.731 x 5.159)			980	1,570	280 (25.400)	
3.1250 (79.375)	2.5000 (63.500)	.3750 (9.525)	2.5625 (65.088)	.2812 x .4060 x .2656 (7.144 x 10.319 x 6.747)			1,570	2,740	580 (31.750)	
3.7500 (95.250)	3.0000 (76.200)	.5000 (12.700)	3.0625 (77.788)	.3440 x .5000 x .3280 (8.731 x 12.700 x 8.334)			2,180	4,020	930 (38.100)	
4.3750 (111.125)	3.5000 (88.900)	.5000 (12.700)	3.6875 (93.662)	.3440 x .5000 x .3280 (8.731 x 12.700 x 8.334)	.0008 (20)	.0008 (20)	3,820	7,940	1,580 (50.800)	
5.3750 (136.525)	4.3750 (111.125)	.7500 (19.050)	4.5625 (115.887)	.4062 x .6250 x .3750 (10.319 x 15.875 x 9.525)			4,700	10,000	3,200 (63.500)	
6.1250 (155.575)	5.0000 (127.000)	.7500 (19.050)	5.3125 (134.937)	.4062 x .6250 x .3750 (10.319 x 15.875 x 9.525)			7,350	16,000	5,000 (76.200)	
8.0000 (203.200)	6.7500 (171.450)	.8750 (22.225)	7.0000 (177.800)	.5000 x .7125 x .5000 (12.700 x 18.097 x 12.700)			14,100	34,800	11,300 (101.600)	

1N ≅ 0.225lbf 1kg ≅ 2.205lbf

SWF-W TYPE (Inch Standard)

– Round Flange Double-Wide Type –

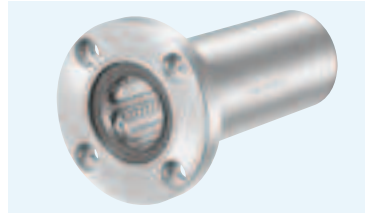

part number structure

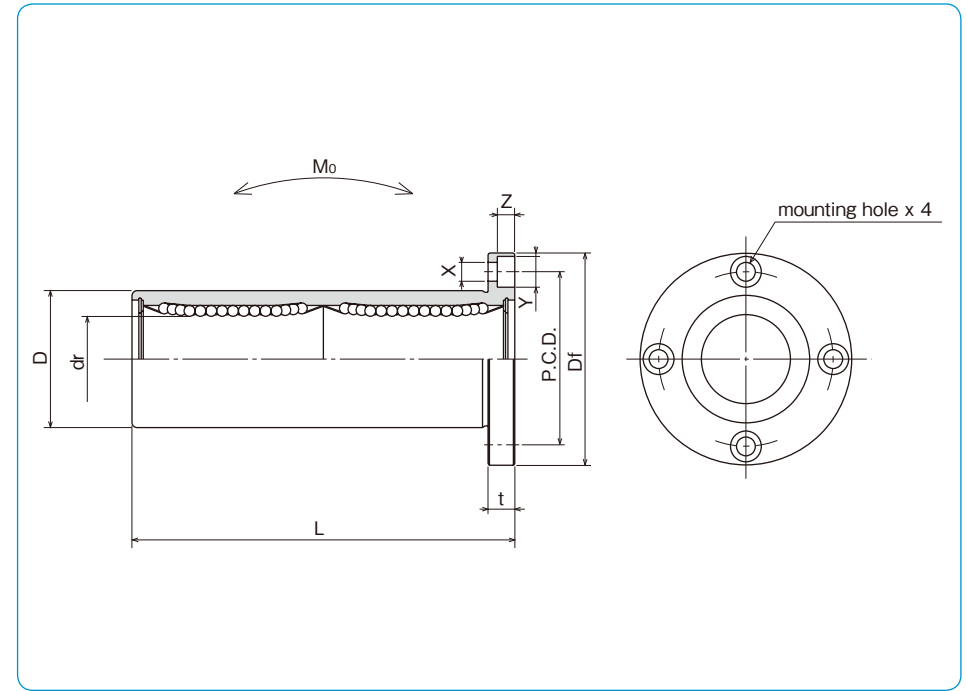
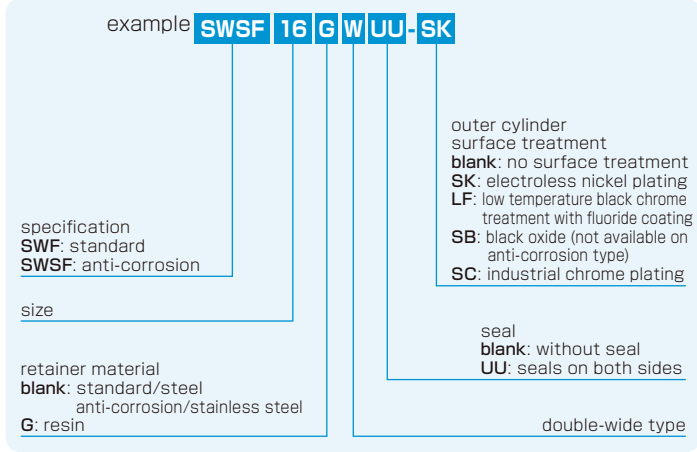

part number				number of ball circuits	major dimensions		
standard steel retainer	anti-corrosion resin retainer	stainless steel retainer	resin retainer		dr	D	L
inch (mm)	inch (mm)	inch (mm)	inch (mm)	inch (mm)	inch (mm)	inch (mm)	
SWF 4W	SWF 4GW	SWSF 4W	SWSF 4GW	4	.2500 (6.350)	.5000 (12.700)	1.3750 (34.925)
SWF 6W	SWF 6GW	SWSF 6W	SWSF 6GW	4	.3750 (9.525)	.6250 (15.875)	1.5938 (40.481)
SWF 8W	SWF 8GW	SWSF 8W	SWSF 8GW	4	.5000 (12.700)	.8750 (22.225)	2.3750 (60.325)
SWF10W	SWF10GW	SWSF10W	SWSF10GW	4	.6250 (15.875)	1.1250 (28.575)	2.8125 (71.438)
SWF12W	SWF12GW	SWSF12W	SWSF12GW	5	.7500 (19.050)	1.2500 (31.750)	3.0937 (78.581)
SWF16W	SWF16GW	SWSF16W	SWSF16GW	6	1.0000 (25.400)	1.5625 (39.688)	4.2813 (108.744)
SWF20W	SWF20GW	SWSF20W	SWSF20GW	6	1.2500 (31.750)	2.0000 (50.800)	5.0000 (127.000)
SWF24W	SWF24GW	SWSF24W	SWSF24GW	6	1.5000 (38.100)	2.3750 (60.325)	5.6875 (144.463)
SWF32W	SWF32GW	SWSF32W	SWSF32GW	6	2.0000 (50.800)	3.0000 (76.200)	7.7500 (196.850)

Df	flange			eccentricity	perpendicularity	basic load rating		allowable static moment Mo	mass	shaft diameter		
	t	P.C.D.	X x Y x Z			dynamic C	static Co					
inch (mm)	inch (mm)	inch (mm)	inch (mm)	inch (mm)	inch (mm)	N	N	N · m	g	inch (mm)		
1.2500 (31.750)	.2188 (5.556)	.8750 (22.225)	.1563 x .2500 x .1406 (3.969 x 6.350 x 3.572)	.0006 (15)	.0006 (15)	323	530	2.0	40	1/4 (6.350)		
1.5000 (38.100)	.2500 (6.350)	1.0625 (26.988)	.1875 x .2969 x .1719 (4.763 x 7.541 x 4.366)			353	630	2.7	60	3/8 (9.525)		
1.7500 (44.450)	.2500 (6.350)	1.3125 (33.338)	.1875 x .2969 x .1719 (4.763 x 7.541 x 4.366)			813	1,570	11.5	126	1/2 (12.700)		
2.0000 (50.800)	.2500 (6.350)	1.5625 (39.688)	.1875 x .2969 x .1719 (4.763 x 7.541 x 4.366)			1,230	2,350	20.0	215	5/8 (15.875)		
2.1875 (55.563)	.3125 (7.938)	1.7188 (43.656)	.2188 x .3438 x .2031 (5.556 x 8.731 x 5.159)			.0008 (20)	.0008 (20)	1,370	2,740	26.5	280	3/4 (19.050)
2.5000 (63.500)	.3125 (7.938)	2.0313 (51.594)	.2188 x .3438 x .2031 (5.556 x 8.731 x 5.159)					1,570	3,140	41.2	515	1 (25.400)
3.1250 (79.375)	.3750 (9.525)	2.5625 (65.088)	.2813 x .4063 x .2656 (7.144 x 10.319 x 6.747)					2,500	5,490	84.8	1,020	1-1/4 (31.750)
3.7500 (95.250)	.5000 (12.700)	3.0625 (77.788)	.3437 x .5000 x .3281 (8.731 x 12.700 x 8.334)					3,430	8,040	143	1,630	1-1/2 (38.100)
4.3750 (111.125)	.5000 (12.700)	3.6875 (93.662)	.3437 x .5000 x .3281 (8.731 x 12.700 x 8.334)			.0012 (30)	.0012 (30)	6,080	15,900	399	2,800	2 (50.800)

1N=0.225lbf 1N · m=0.738lb · ft
1kg=2.205lbs

SWK-W TYPE (Inch Standard)

– Square Flange Double-Wide Type –

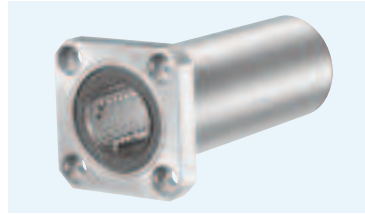

part number structure

example **SWSK 16 G W UU -SK**

specification SWK : standard SWSK : anti-corrosion	size	retainer material blank : standard/steel anti-corrosion/stainless steel G : resin	outer cylinder surface treatment blank : no surface treatment SK : electroless nickel plating LF : low temperature black chrome treatment with fluoride coating SB : black oxide (not available on anti-corrosion type) SC : industrial chrome plating	seal blank : without seal UU : seals on both sides	double-wide type
--	------	--	--	--	------------------

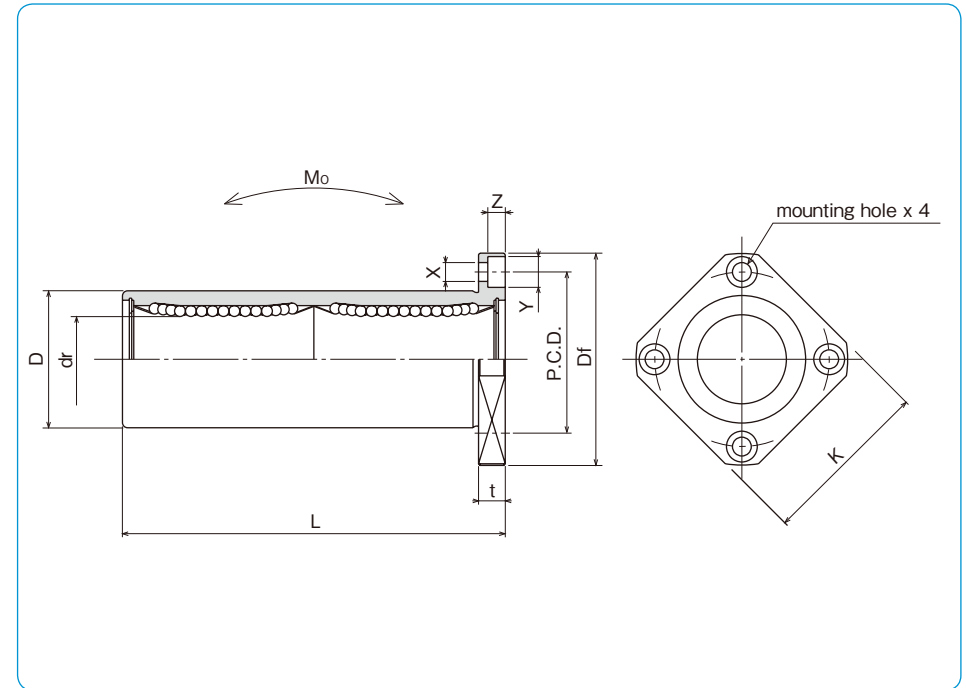

part number				number of ball circuits	major dimensions				
standard steel retainer	anti-corrosion resin retainer	stainless retainer	resin retainer		dr		D		L
				inch (mm)	tolerance inch/(μm)	inch (mm)	tolerance inch/(μm)	±.012 (±0.3) inch/(mm)	
SWK 4W	SWK 4GW	SWSK 4W	SWSK 4GW	4	.2500 (6.350)		.5000 (12.700)	⁰ _{-.00050 (-13)}	1.3750 (34.925)
SWK 6W	SWK 6GW	SWSK 6W	SWSK 6GW	4	.3750 (9.525)	⁰ _{-.00040 (-10)}	.6250 (15.875)	⁰ _{-.00065 (-16)}	1.5938 (40.481)
SWK 8W	SWK 8GW	SWSK 8W	SWSK 8GW	4	.5000 (12.700)		.8750 (22.225)	⁰ _{-.00075 (-19)}	2.3750 (60.325)
SWK 10W	SWK 10GW	SWSK 10W	SWSK 10GW	4	.6250 (15.875)		1.1250 (28.575)	⁰ _{-.00090 (-22)}	2.8125 (71.438)
SWK 12W	SWK 12GW	SWSK 12W	SWSK 12GW	5	.7500 (19.050)	⁰ _{-.00050 (-12)}	1.2500 (31.750)	⁰ _{-.00075 (-19)}	3.0937 (78.581)
SWK 16W	SWK 16GW	SWSK 16W	SWSK 16GW	6	1.0000 (25.400)		1.5625 (39.688)	⁰ _{-.00090 (-22)}	4.2813 (108.744)
SWK 20W	SWK 20GW	SWSK 20W	SWSK 20GW	6	1.2500 (31.750)	⁰ _{-.00060 (-15)}	2.0000 (50.800)	⁰ _{-.00100 (-25)}	5.0000 (127.000)
SWK 24W	SWK 24GW	SWSK 24W	SWSK 24GW	6	1.5000 (38.100)		2.3750 (60.325)	⁰ _{-.00100 (-25)}	5.6875 (144.463)
SWK 32W	SWK 32GW	SWSK 32W	SWSK 32GW	6	2.0000 (50.800)		3.0000 (76.200)	⁰ _{-.00100 (-25)}	7.7500 (196.850)

flange					eccentricity inch (μm)	perpendicularity inch (μm)	basic load rating		allowable static moment Mo N·m	mass g	shaft diameter inch/(mm)
Df	K	t	P.C.D.	X×Y×Z			dynamic C N	static Co N			
1.2500 (31.750)	1.0000 (25.400)	.2188 (5.556)	.8750 (22.225)	.1563×.2500×.1406 (3.969×6.350×3.572)	.0006 (15)	.0006 (15)	323	530	2.0	33 (6.350)	
1.5000 (38.100)	1.2500 (31.750)	.2500 (6.350)	1.0625 (26.988)	.1875×.2969×.1719 (4.763×7.541×4.366)			353	630	2.7	45 (9.525)	
1.7500 (44.450)	1.3750 (34.925)	.2500 (6.350)	1.3125 (33.338)	.1875×.2969×.1719 (4.763×7.541×4.366)			813	1,570	11.5	106 (12.700)	
2.0000 (50.800)	1.5000 (38.100)	.2500 (6.350)	1.5625 (39.688)	.1875×.2969×.1719 (4.763×7.541×4.366)			1,230	2,350	20.0	200 (15.875)	
2.1875 (55.563)	1.6875 (42.863)	.3125 (7.938)	1.7188 (43.656)	2.188×.3438×.2031 (5.556×8.731×5.159)	.0008 (20)	.0008 (20)	1,370	2,740	26.5	240 (19.050)	
2.5000 (63.500)	2.0000 (50.800)	.3125 (7.938)	2.0313 (51.594)	2.188×.3438×.2031 (5.556×8.731×5.159)			1,570	3,140	41.2	470 (25.400)	
3.1250 (79.375)	2.5000 (63.500)	.3750 (9.525)	2.5625 (65.088)	2.813×.4063×.2656 (7.144×10.319×6.747)			2,500	5,490	84.8	935 (31.750)	
3.7500 (95.250)	3.0000 (76.200)	.5000 (12.700)	3.0625 (77.788)	3.437×.5000×.3281 (8.731×12.700×8.334)			3,430	8,040	143	1,460 (38.100)	
4.3750 (111.125)	3.5000 (88.900)	.5000 (12.700)	3.6875 (93.662)	3.437×.5000×.3281 (8.731×12.700×8.334)	.0012 (30)	.0012 (30)	6,080	15,900	399	2,620 (50.800)	

1N≒0.225lbf 1N·m≒0.738lb·ft
1kg≒2.205lbs

GM TYPE

– Single Type –



part number structure

example **GM 25 UU**

GM type
inner contact diameter (dr)
seal
blank: without seal
UU: seals on both sides

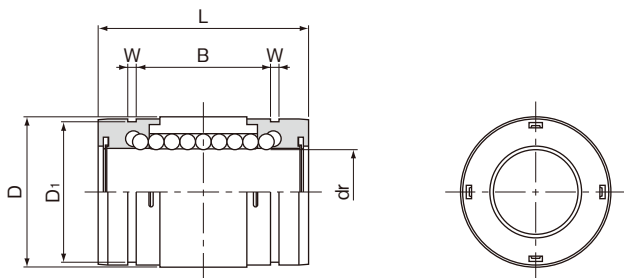

part number	number of ball circuits	dr mm	major dimensions							basic load rating dynamic C N	static Co N	mass g
			tolerance μm	D mm	tolerance μm	L mm	B mm	W mm	D ₁ mm			
GM 6	4	6	0	12	0	19	11.3	1.1	11.5	206	265	5
GM 8	4	8		15	-11	24	15.3	1.1	14.3	274	392	10
GM10	4	10		19	0	29	19.4	1.3	18	372	549	18
GM12	4	12	-9	21	0	30	20.4	1.3	20	510	784	23
GM13	4	13		23	-13	32	20.4	1.3	22	510	784	27
GM16	4	16		28	0	37	23.3	1.6	27	774	1,180	45
GM20	6	20	0	32	0	42	27.3	1.6	30.5	882	1,370	70
GM25	6	25		40	-16	59	37.3	1.85	38	980	1,570	150
GM30	6	30		45	0	64	40.8	1.85	43	1,570	2,740	180

GM-AJ type (clearance adjustable type) is also manufactured. Please contact NB for details.

1N \approx 0.102kgf

GM-W TYPE

– Double-Wide Type –

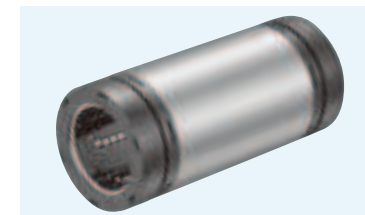

part number structure

example **GM 25 W UU**

GM type
inner contact diameter (dr)
seals on both sides
double-wide type

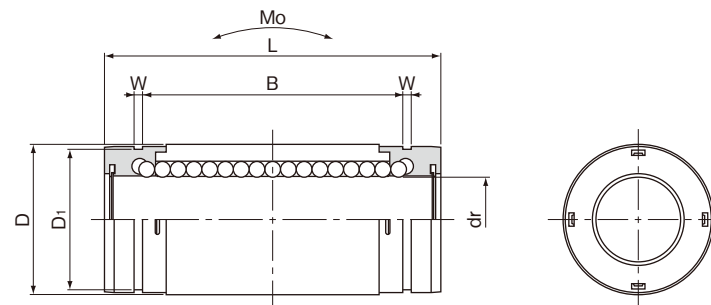

part number	number of ball circuits	dr mm	major dimensions							basic load rating dynamic C N	static Co N	allowable static moment Mo N · m	mass g
			tolerance μm	D mm	tolerance μm	L mm	B mm	W mm	D ₁ mm				
GM 6W UU	4	6	0	12	0	28	20.3	1.1	11.5	323	530	1.5	9
GM 8W UU	4	8		15	-13	36	27.3	1.1	14.3	431	784	3.3	18
GM10W UU	4	10		19	0	41	31.4	1.3	18	588	1,100	5.0	31
GM12W UU	4	12	-10	21	0	46	36.4	1.3	20	813	1,570	7.6	42
GM13W UU	4	13		23	-16	48	36.4	1.3	22	813	1,570	8.1	50
GM16W UU	4	16		28	0	53	39.3	1.6	27	1,230	2,350	13.8	76
GM20W UU	6	20	0	32	0	65	50.3	1.6	30.5	1,400	2,740	20.0	130
GM25W UU	6	25		40	-19	91	69.3	1.85	38	1,560	3,140	34.8	280
GM30W UU	6	30		45	0	99	75.8	1.85	43	2,490	5,490	57.5	334

*UU type is standard.

1N \approx 0.102kgf 1N · m \approx 0.102kgf · m

GW TYPE (Inch Standard)

– Single Type –

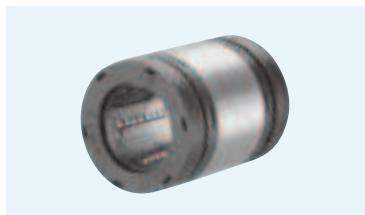

part number structure

example **GW 16 UU**

GW type

size

seal
blank: without seal
UU: seals on both sides

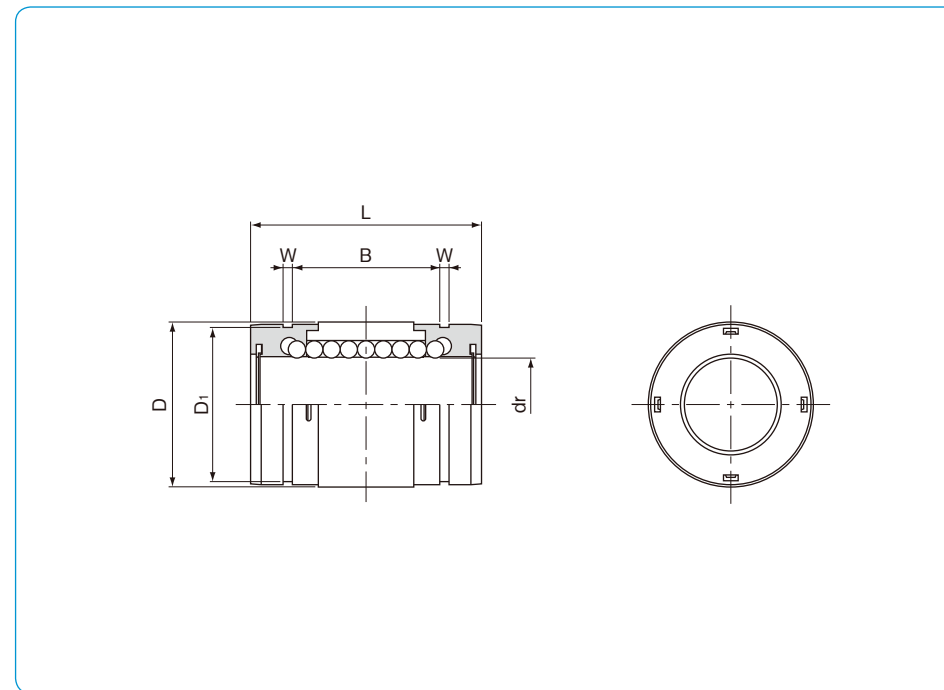

part number	number of ball circuits	major dimensions				
		dr		D		L
		inch/(mm)	tolerance inch/(μ m)	inch/(mm)	tolerance inch/(μ m)	inch/(mm)
GW 4	4	.2500 (6.350)	0 - .00040 (-10)	.5000 (12.700)	0 - .00045 (-11)	.7500 (19.050)
GW 6	4	.3750 (9.525)		.6250 (15.875)	0	.8750 (22.225)
GW 8	4	.5000 (12.700)		.8750 (22.225)	- .00050 (-13)	1.2500 (31.750)
GW10	4	.6250 (15.875)		1.1250 (28.575)		1.5000 (38.100)
GW12	6	.7500 (19.050)		1.2500 (31.750)	0 - .00065 (-16)	1.6250 (41.275)
GW16	6	1.0000 (25.400)		1.5625 (39.688)		2.2500 (57.150)
GW20	6	1.2500 (31.750)		2.0000 (50.800)	0 - .00075 (-19)	2.6250 (66.675)

			basic load rating		mass g
B	W	D ₁	dynamic C N	static C ₀ N	
inch/(mm)	inch/(mm)	inch/(mm)			
.4329 (10.996)	.0390 (0.992)	.4687 (11.906)	206	265	5.4
.5577 (14.166)	.0390 (0.992)	.5880 (14.935)	225	314	7.8
.8710 (22.123)	.0459 (1.168)	.8209 (20.853)	510	784	26
.9920 (25.197)	.0559 (1.422)	1.0590 (26.899)	774	1,180	51
1.0538 (26.767)	.0559 (1.422)	1.1760 (29.870)	862	1,370	72
1.6187 (41.115)	.0679 (1.727)	1.4687 (37.306)	980	1,570	138
1.8687 (47.465)	.0679 (1.727)	1.8859 (47.904)	1,570	2,740	269

1N≅0.225lbf 1kg≅2.205lbs

SMA TYPE

– Block Type –



part number structure

example **SMSA 25 G UU**

specification SMA: standard SMSA: anti-corrosion	inner contact diameter	retainer material blank: standard/steel anti-corrosion/stainless steel G: resin	seal blank: without seal UU: seals on both sides
--	------------------------	--	--

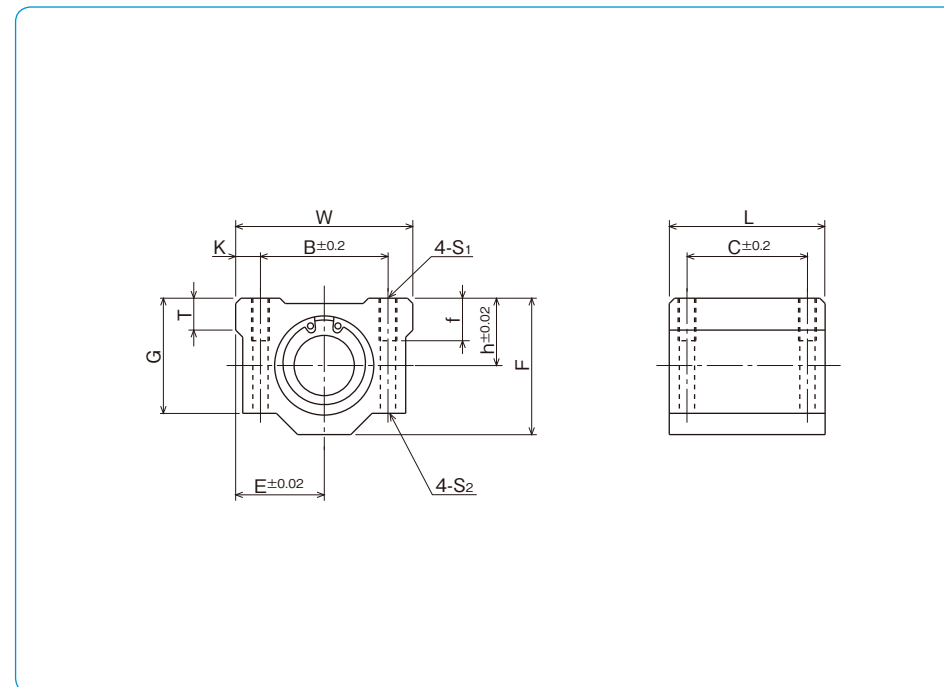

part number	inner contact diameter		outer dimensions							major dimensions	
	mm	tolerance	h mm	E mm	W mm	L mm	F mm	G mm	T mm	C	T
		μm									
SMA 3GUU	3	0	5	8	16	13	10	8	—	—	—
SMA 4GUU	4	- 8	5.5	8.5	17	15	11	9	—	—	—
SMA 5GUU	5	- 8	7	11	22	18	14	11	—	—	—
SMA 6GUU	6	- 8	9	15	30	25	18	15	6	—	—
SMA 8GUU	8	- 8	11	17	34	30	22	18	6	—	—
SMA 10GUU	10	0	13	20	40	35	26	21	8	—	—
SMA 12GUU	12	- 9	15	21	42	36	28	24	8	—	—
SMA 13GUU	13	- 9	15	22	44	39	30	24.5	8	—	—
SMA 16GUU	16	- 9	19	25	50	44	38.5	32.5	9	—	—
SMA 20GUU	20	- 10	21	27	54	50	41	35	11	—	—
SMA 25GUU	25	0	26	38	76	67	51.5	42	12	—	—
SMA 30GUU	30	- 10	30	39	78	72	59.5	49	15	—	—
SMA 35GUU	35	- 10	34	45	90	80	68	54	18	—	—
SMA 40GUU	40	0	40	51	102	90	78	62	20	—	—
SMA 50GUU	50	- 12	52	61	122	110	102	80	25	—	—
SMA 60GUU	60	0/-15	58	66	132	122	114	94	30	—	—

mounting dimensions						basic load rating		* mass g	shaft diameter mm
B mm	C mm	K mm	S ₁	f mm	S ₂ mm	dynamic C N	static Co N		
11	8	2.5	M2	—	—	69	105	5	3
12	10	2.5	M3	—	—	88	127	7	4
16	12	3	M3	—	—	167	206	14	5
20	15	5	M4	8	3.4	206	265	34	6
24	18	5	M4	8	3.4	274	392	52	8
28	21	6	M5	12	4.3	372	549	92	10
30.5	26	5.75	M5	12	4.3	510	784	102	12
33	26	5.5	M5	12	4.3	510	784	120	13
36	34	7	M5	12	4.3	774	1,180	200	16
40	40	7	M6	12	5.2	882	1,370	255	20
54	50	11	M8	18	7	980	1,570	600	25
58	58	10	M8	18	7	1,570	2,740	735	30
70	60	10	M8	18	7	1,670	3,140	1,100	35
80	60	11	M10	25	8.7	2,160	4,020	1,590	40
100	80	11	M10	25	8.7	3,820	7,940	3,340	50
108	90	12	M12	25	10.7	4,700	10,000	4,270	60

* Mass of resin retainer type

1N=0.102kgf

SMA-W TYPE

– Double-Wide Block Type –



part number structure

example **SMSA 25 G W UU**

specification
SMA: standard
SMSA: anti-corrosion

inner contact diameter

retainer material
blank: standard/steel
anti-corrosion/stainless steel
G: resin

seal
blank: without seal
UU: seals on both sides

double-wide type

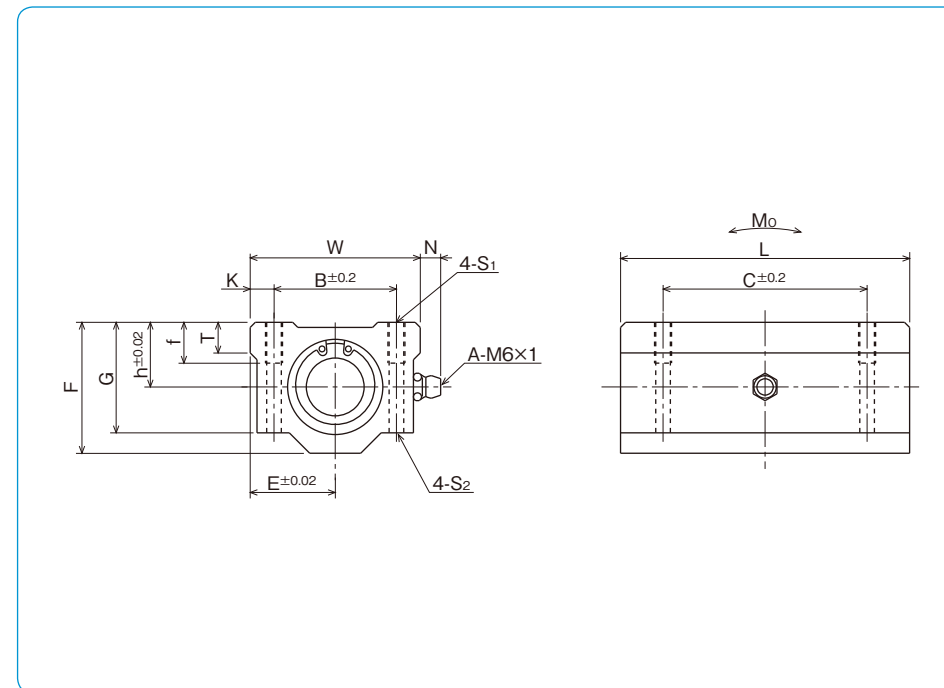

part number	inner contact diameter		major dimensions							
	mm	tolerance	h mm	E mm	W mm	outer dimensions				
		μm				L mm	F mm	G mm	T mm	N mm
SMA 3GWUU	3	0	5	8	16	23	10	8	—	—
SMA 4GWUU	4	- 8	5.5	8.5	17	27	11	9	—	—
SMA 5GWUU	5		7	11	22	33	14	11	—	—
SMA 6GWUU	6		9	15	30	48	18	15	6	7
SMA 8GWUU	8		11	17	34	58	22	18	6	7
SMA10GWUU	10	0	13	20	40	68	26	21	8	7
SMA12GWUU	12	- 9	15	21	42	70	28	24	8	6.5
SMA13GWUU	13		15	22	44	75	30	24.5	8	6.5
SMA16GWUU	16		19	25	50	85	38.5	32.5	9	6
SMA20GWUU	20		21	27	54	96	41	35	11	7
SMA25GWUU	25	0	26	38	76	130	51.5	42	12	4
SMA30GWUU	30	-10	30	39	78	140	59.5	49	15	5
SMA35GWUU	35		34	45	90	155	68	54	18	5.5
SMA40GWUU	40	0	40	51	102	175	78	62	20	5
SMA50GWUU	50	-12	52	61	122	215	102	80	25	5
SMA60GWUU	60	0/-15	58	66	132	240	114	94	30	5

mounting dimensions						basic load rating		allowable static moment	* mass	shaft diameter
B mm	C mm	K mm	S ₁	f mm	S ₂ mm	C N	Co N			
11	16	2.5	M2	—	—	108	206	0.49	10	3
12	20	2.5	M3	—	—	137	255	0.72	13	4
16	25	3	M3	—	—	265	412	1.54	27	5
20	36	5	M4	8	3.4	323	530	2.18	63	6
24	42	5	M4	8	3.4	431	784	4.31	102	8
28	46	6	M5	12	4.3	588	1,100	7.24	180	10
30.5	50	5.75	M5	12	4.3	813	1,570	10.9	205	12
33	50	5.5	M5	12	4.3	813	1,570	11.6	240	13
36	60	7	M5	12	4.3	1,230	2,350	19.7	400	16
40	70	7	M6	12	5.2	1,400	2,740	26.8	570	20
54	100	11	M8	18	7	1,560	3,140	43.4	1,200	25
58	110	10	M8	18	7	2,490	5,490	82.8	1,480	30
70	120	10	M8	18	7	2,650	6,270	110	2,200	35
80	140	11	M10	25	8.7	3,430	8,040	147	3,200	40
100	160	11	M10	25	8.7	6,080	15,900	397	6,700	50
108	180	12	M12	25	10.7	7,550	20,000	530	8,560	60

* Mass of resin retainer type

1N≒0.102kgf 1N · m≒0.102kgf · m

AK TYPE

– Compact Block Type –



part number structure

example **AKS 25 G UU**

specification
AK: standard
AKS: anti-corrosion

seal
blank: without seal
UU: seals on both sides

retainer material
blank: standard/steel
 anti-corrosion/stainless steel
G: resin

inner contact diameter

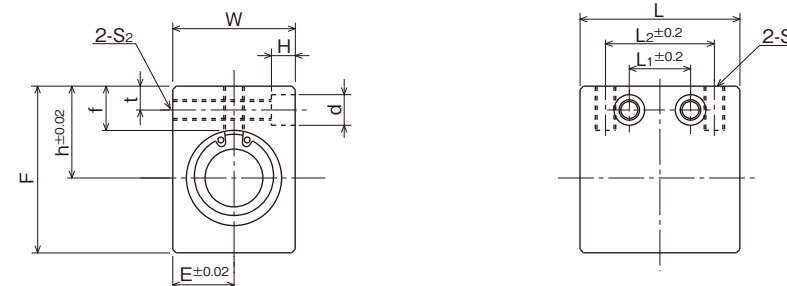

part number	inner contact diameter		outer dimensions				major dimensions		
	mm	tolerance μm	h mm	E mm	W mm	L mm	F mm	L ₂ mm	S ₁
AK 6GUU	6	0 - 9	14	8	16	27	22	18	M4
AK 8GUU	8		16	10	20	32	26	20	M5
AK10GUU	10		19	13	26	39	32	27	M6
AK12GUU	12		20	14	28	40	34	27	M6
AK13GUU	13		25	15	30	42	43	28	M6
AK16GUU	16		27	18	36	47	49	32	M6
AK20GUU	20	0 -10	31	21	42	52	54	36	M8
AK25GUU	25		37	26	52	69	65	42	M10
AK30GUU	30		40	29	58	74	71	44	M10

mounting dimensions						basic load rating		* mass g	shaft diameter mm
f mm	L ₁ mm	t mm	S ₂	d mm	H mm	dynamic C N	static C ₀ N		
8	9	5	M4	6	5	206	265	21.5	6
8.5	10	5	M4	6	5	274	392	40	8
9.5	15	6	M5	8	6	372	549	80	10
9.5	15	6	M5	8	6	510	784	90	12
13.5	16	7	M6	9	7	510	784	132	13
13	18	7	M6	9	7	774	1,180	204	16
15	18	8	M8	11	8	882	1,370	272	20
17	22	9	M10	14	10	980	1,570	574	25
17.5	22	9	M10	14	10	1,570	2,740	710	30

* Mass of resin retainer type

1N=0.102kgf

AK-W TYPE

– Double-Wide Compact Block Type –



part number structure

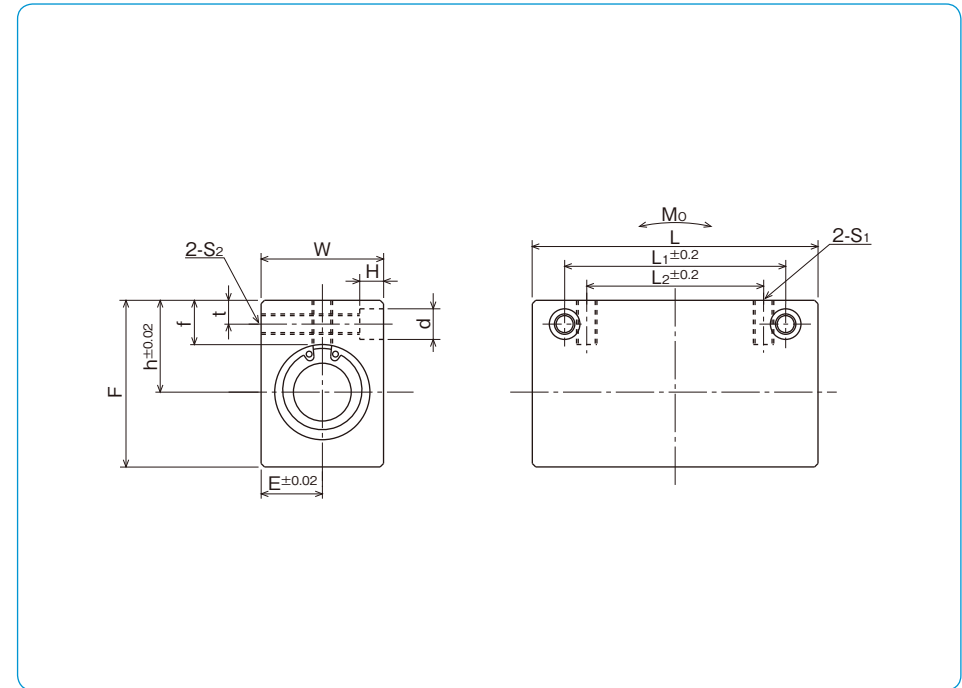
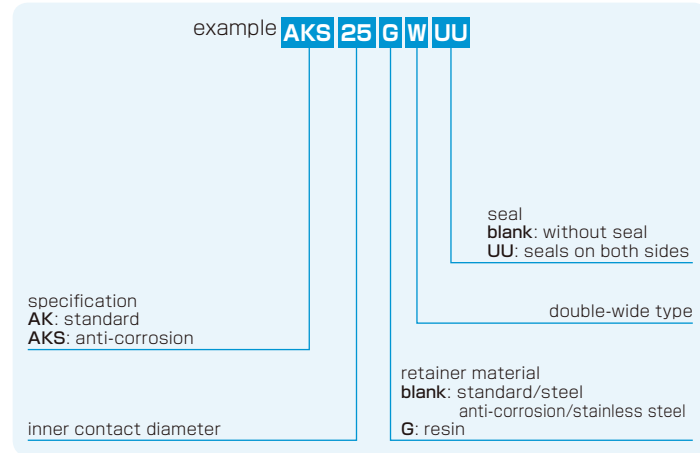

part number	inner contact diameter		outer dimensions				major dimensions		
	mm	tolerance μm	h mm	E mm	W mm	L mm	F mm	L ₂ mm	S ₁
AK 6GWUU	6	0 - 9	14	8	16	46	22	20	M4
AK 8GWUU	8		16	10	20	56	26	30	M5
AK10GWUU	10		19	13	26	68	32	36	M6
AK12GWUU	12		20	14	28	70	34	36	M6
AK13GWUU	13		25	15	30	74	43	42	M6
AK16GWUU	16		27	18	36	84	49	52	M6
AK20GWUU	20	0 -10	31	21	42	94	54	58	M8
AK25GWUU	25		37	26	52	128	65	80	M10
AK30GWUU	30		40	29	58	138	71	90	M10

mounting dimensions						basic load rating		allowable static moment	* mass	shaft diameter
f mm	L ₁ mm	t mm	S ₂	d mm	H mm	dynamic C N	static Co N			
8	30	5	M4	6	5	323	530	2.18	40	6
8.5	42	5	M4	6	5	431	784			
9.5	50	6	M5	8	6	588	1,100	7.24	150	10
9.5	50	6	M5	8	6	813	1,570			
13.5	55	7	M6	9	7	813	1,570	11.6	248	13
13	65	7	M6	9	7	1,230	2,350			
15	70	8	M8	11	8	1,400	2,740	26.8	520	20
17	100	9	M10	14	10	1,560	3,140			
17.5	110	9	M10	14	10	2,490	5,490	82.8	1,384	30

* Mass of resin retainer type

1N \approx 0.102kgf 1N · m \approx 0.102kgf · m

SMB TYPE

– Block Type –

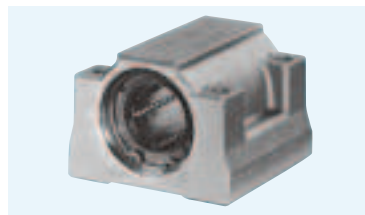

part number structure

example **SMSB 25 G UU**

specification	retainer material
SMB : standard	blank : standard/steel
SMSB : anti-corrosion	anti-corrosion/stainless steel
inner contact diameter	G : resin
	seal
	blank : without seal
	UU : seals on both sides

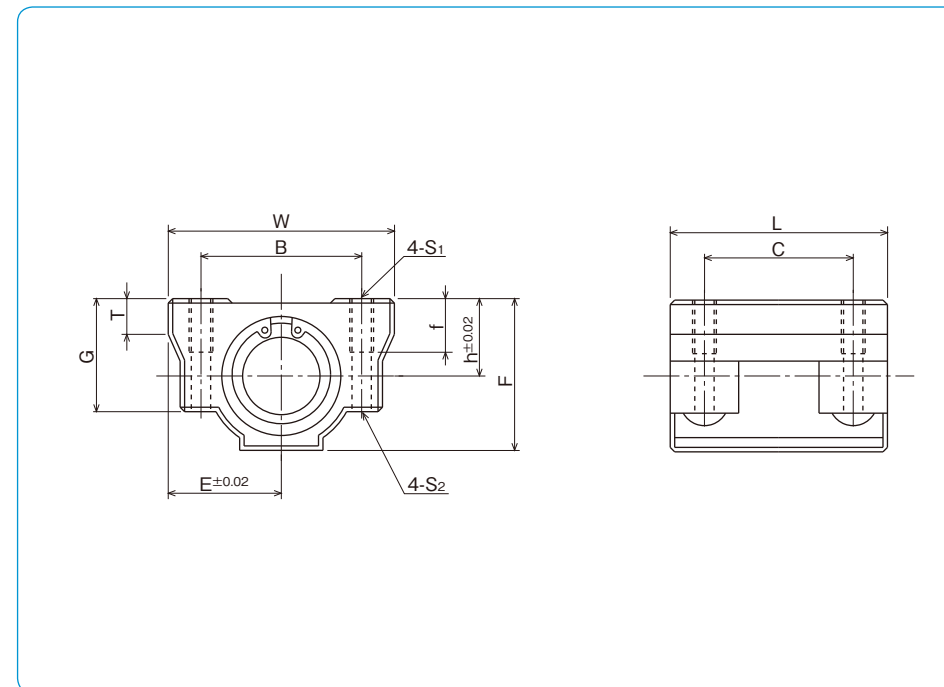

part number	inner contact diameter		outer dimensions							major dimensions	
	mm	tolerance μm	h	E	W	L	F	G	T		
			mm	mm	mm	mm	mm	mm	mm	mm	mm
SMB13GUU	13	0	16	22	44	39	31	22	8		
SMB16GUU	16	- 9	19	25	50	49	37	28	9		
SMB20GUU	20	0	21	27	54	55	41	31	11		
SMB25GUU	25	-10	26	38	76	73	51	38	12		
SMB30GUU	30		30	39	78	80	57	45	15		
SMB40GUU	40	0/-12	40	51	102	96	75	59	22		

mounting dimensions					basic load rating		* mass	shaft diameter
B	C	S ₁	f	S ₂	dynamic	static		
mm	mm		mm	mm	C	Co	g	mm
33	26	M5	10	4.3	510	784	120	13
36	34	M5	12	4.3	774	1,180	170	16
40	40	M6	12	5.1	882	1,370	210	20
54	50	M8	18	6.8	980	1,570	500	25
58	58	M8	18	6.8	1,570	2,740	600	30
80	60	M10	25	8.6	2,160	4,020	1,200	40

* Mass of resin retainer type

1N≒0.102kgf

SMP TYPE

– Pillow Block Type –

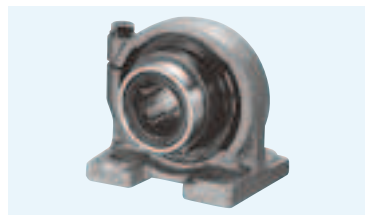

part number structure

example **SMP 25 G UU**

SMP type

inner contact diameter

seal
blank: without seal
UU: seals on both sides

retainer material
blank: steel
G: resin

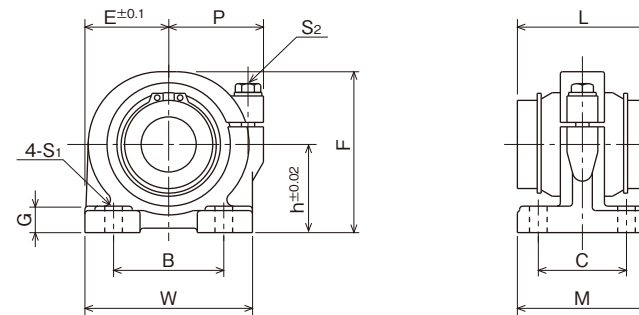

part number	inner contact diameter		outer dimensions							major dimensions	
	mm	tolerance μm	h mm	E mm	W mm	L mm	F mm	G mm	M mm		
	SMP13GUU	13	0	25	25	50	32	46	8	36	
SMP16GUU	16	- 9	29	27.5	55	37	53	10	40		
SMP20GUU	20	0	34	32.5	65	42	62	12	48		
SMP25GUU	25	-10	40	38	76	59	73	12	59		
SMP30GUU	30	0	45	42.5	85	64	84	15	69		
SMP35GUU	35	0	50	49	98	70	94	15	76		
SMP40GUU	40	-12	60	62	124	80	112	18	86		
SMP50GUU	50	-12	70	72	144	100	134	20	105		
SMP60GUU	60	0/-15	82	84.5	169	110	154	23	115		

P mm	mounting dimensions			adjustment screw size S ₂	basic load rating		* mass g	shaft diameter mm
	B mm	C mm	S ₁ mm		dynamic C N	static C ₀ N		
30	30	26	7 (M5)	M5	510	784	270	13
32	35	29	7 (M5)	M5	774	1,180	380	16
37	40	35	8 (M6)	M6	882	1,370	680	20
43	50	40	8 (M6)	M6	980	1,570	1,000	25
49	58	46	10 (M8)	M8	1,570	2,740	1,400	30
58	62	53	12 (M10)	M10	1,670	3,140	2,100	35
68	76	64	12 (M10)	M10	2,160	4,020	3,700	40
80	100	70	14 (M12)	M12	3,820	7,940	6,100	50
88	115	80	14 (M12)	M12	4,700	10,000	8,700	60

* Mass of resin retainer type

1N=0.102kgf

SMJ TYPE

– Clearance Adjustable Type –

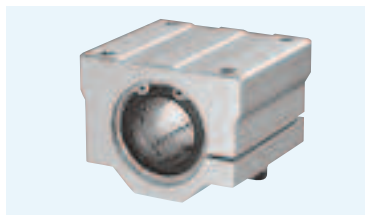

part number structure

example **SMSJ 25 G UU**

specification SMJ: standard SMSJ: anti-corrosion	inner contact diameter	retainer material blank: standard/steel* anti-corrosion/stainless steel* G: resin	seal blank: without seal UU: seals on both sides
--	------------------------	--	--

*Size 10 is provided with resin retainer type only.

part number	inner contact diameter mm	major dimensions							
		h mm	E mm	outer dimensions			G mm	T mm	B mm
				W mm	L mm	F mm			
SMJ10GUU	10	13	20	40	35	26	21	8	28
SMJ12GUU	12	15	21	42	36	28	24	8	30.5
SMJ13GUU	13	15	22	44	39	30	24.5	8	33
SMJ16GUU	16	19	25	50	44	38.5	32.5	9	36
SMJ20GUU	20	21	27	54	50	41	35	11	40
SMJ25GUU	25	26	38	76	67	51.5	42	12	54
SMJ30GUU	30	30	39	78	72	59.5	49	15	58
SMJ35GUU	35	34	45	90	80	68	54	18	70
SMJ40GUU	40	40	51	102	90	78	62	20	80
SMJ50GUU	50	52	61	122	110	102	80	25	100
SMJ60GUU	60	58	66	132	122	114	94	30	108

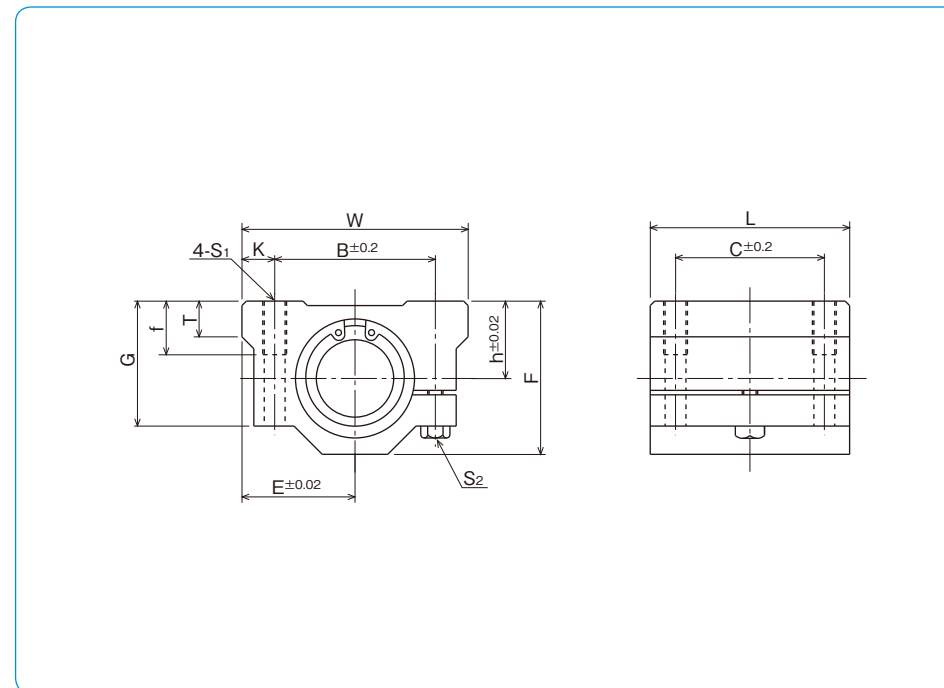

mounting dimensions				adjustment screw size S ₂	basic load rating		* mass g	shaft diameter mm
C mm	K mm	S ₁	f mm		dynamic C N	static C ₀ N		
21	6	M5	12	M4	372	549	92	10
26	5.75	M5	12	M4	510	784	102	12
26	5.5	M5	12	M4	510	784	120	13
34	7	M5	12	M4	774	1,180	200	16
40	7	M6	12	M5	882	1,370	255	20
50	11	M8	18	M6	980	1,570	600	25
58	10	M8	18	M6	1,570	2,740	735	30
60	10	M8	18	M6	1,670	3,140	1,100	35
60	11	M10	25	M8	2,160	4,020	1,590	40
80	11	M10	25	M8	3,820	7,940	3,340	50
90	12	M12	25	M10	4,700	10,000	4,270	60

* Mass of resin retainer type

1N=0.102kgf

SME TYPE

– Open Block Type –

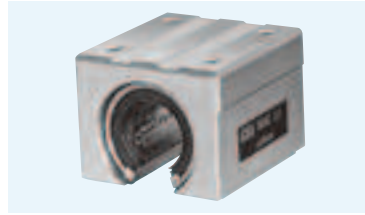

part number structure

example **SMSE 25 G UU**

specification SME: standard SMSE: anti-corrosion	inner contact diameter	retainer material blank: standard/steel* anti-corrosion/stainless steel* G: resin	seal blank: without seal UU: seals on both sides
--	------------------------	--	--

*Size 10 is provided with resin retainer type only.

part number	inner contact diameter mm	outer dimensions			major dimensions				
		h mm	E mm	W mm	L mm	F mm	T mm	h ₁ mm	θ
SME10GUU	10	15	18	36	32	24	7	6	80°
SME13GUU	13	17	20	40	39	28	8	8.5	80°
SME16GUU	16	20	22.5	45	45	33	9	10	80°
SME20GUU	20	23	24	48	50	39	11	10	60°
SME25GUU	25	27	30	60	65	47	14	11.5	50°
SME30GUU	30	33	35	70	70	56	15	14	50°
SME35GUU	35	37	40	80	80	63	18	16	50°
SME40GUU	40	42	45	90	90	72	20	19	50°
SME50GUU	50	53	60	120	110	92	25	23	50°

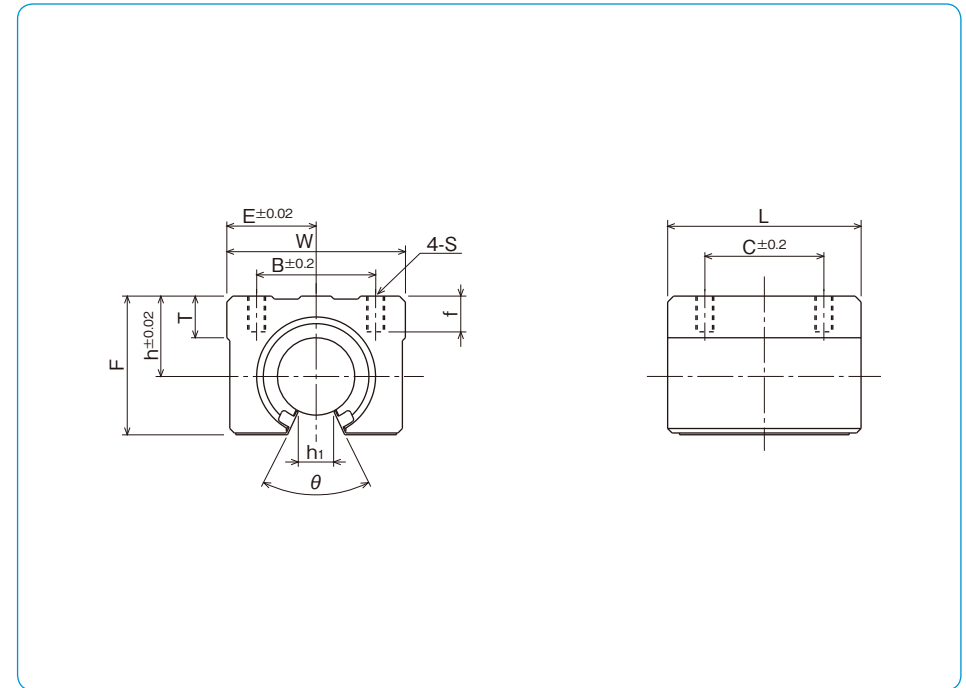

B mm	mounting dimensions			basic load rating		* mass g	shaft diameter mm
	C mm	S	f mm	dynamic C N	static Co N		
25	20	M5	10	372	549	65	10
28	26	M5	10	510	784	100	13
32	30	M5	12	774	1,180	150	16
35	35	M6	12	882	1,370	200	20
40	40	M6	12	980	1,570	450	25
50	50	M8	18	1,570	2,740	630	30
55	55	M8	18	1,670	3,140	925	35
65	65	M10	20	2,160	4,020	1,330	40
94	80	M10	20	3,820	7,940	3,000	50

* Mass of resin retainer type

1N=0.102kgf

SME-W TYPE

– Double-wide Open Block Type –

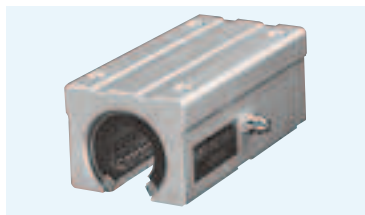

part number structure

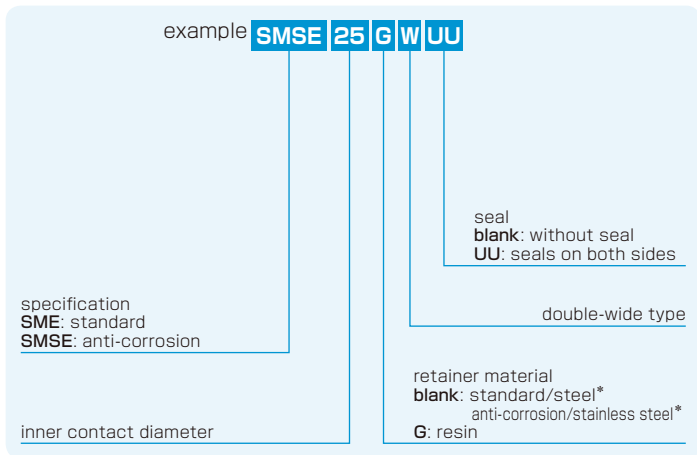

*Size 10 is provided with resin retainer type only.

part number	inner contact diameter mm	outer dimensions							major dimensions	
		h mm	E mm	W mm	L mm	F mm	T mm	N mm	h ₁ mm	θ
SME10GWUU	10	15	18	36	65	24	7	7.5	6	80°
SME13GWUU	13	17	20	40	75	28	8	7.5	8.5	80°
SME16GWUU	16	20	22.5	45	85	33	9	7.5	10	80°
SME20GWUU	20	23	24	48	95	39	11	7.5	10	60°
SME25GWUU	25	27	30	60	130	47	14	7.5	11.5	50°
SME30GWUU	30	33	35	70	140	56	15	7.5	14	50°

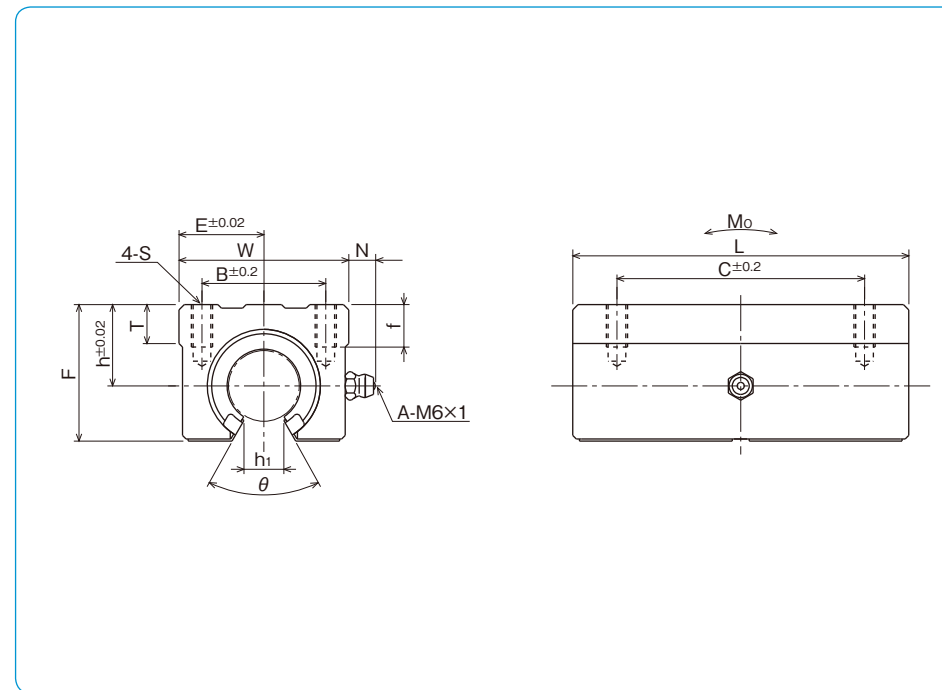

mounting dimensions				basic load rating	allowable static moment	※ mass	shaft diameter	
B mm	C mm	S	f mm	dynamic C N	static C ₀ N	Mo N · m	g	mm
25	40	M5	10	588	1,100	4.63	140	10
28	50	M5	10	813	1,570	7.42	200	13
32	60	M5	12	1,230	2,350	12.6	300	16
35	70	M6	12	1,400	2,740	14.5	400	20
40	90	M6	12	1,560	3,140	24.7	900	25
50	100	M8	18	2,490	5,490	47.2	1,260	30

* Mass of resin retainer type

1N≐0.102kgf 1N · m≐0.102kgf · m

SMD TYPE

— Open Block with Clearance Adjustable Type —

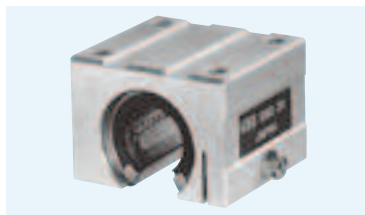

part number structure

example **SMSD 25 G UU**

specification
SMD: standard
SMSD: anti-corrosion

seal
blank: without seal
UU: seals on both sides

retainer material
blank: standard/steel
 anti-corrosion/stainless steel
G: resin

inner contact diameter

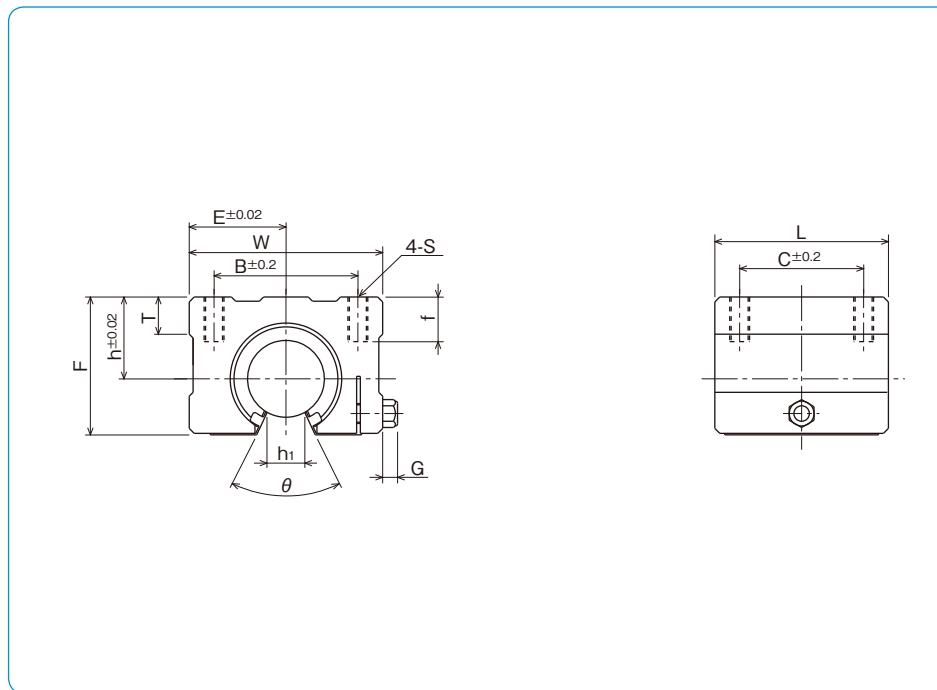

part number	inner contact diameter mm	h mm	E mm	W mm	outer dimensions			major dimensions		
					L mm	F mm	T mm	G mm	h ₁ mm	θ
SMD16GUU	16	20	25	50	45	33	9	6	10	80°
SMD20GUU	20	23	27	54	50	39	11	7	10	60°
SMD25GUU	25	27	38	76	65	47	14	7	11.5	50°
SMD30GUU	30	33	39	78	70	56	15	7	14	50°

mounting dimensions				basic load rating		* mass g	shaft diameter mm
B mm	C mm	S	f mm	dynamic C N	static Co N		
36	30	M5	12	774	1,180	170	16
40	35	M6	12	882	1,370	240	20
54	40	M6	12	980	1,570	580	25
58	50	M8	18	1,570	2,740	720	30

* Mass of resin retainer type

1N≒0.102kgf

CE TYPE

– Non-Clearance Adjustable Type –

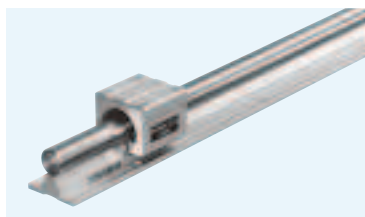

part number structure

CES 25 - 2 - 500

specification
CE: standard
CES: anti-corrosion

shaft diameter

total length

number of blocks
 attached to one shaft

※Bush inside is a resin retainer type with seals.

part number		shaft diameter mm	assembly dimension			block dimension										major dimensions				
standard	anti-corrosion		H mm	h mm	W ₁ mm	W ₂ mm	L ₁ mm	B ₁ mm	C mm	T ₁ mm	f mm	S ₁	F mm	W ₃ mm	B ₂ mm	T ₂ mm	P mm	S ₂ mm		
CE16	CES16	16	45	25	2.5	45	45	32	30	9	12	M5	33	40	30	5	150	5.5		
CE20	CES20	20	50	27	1.5	48	50	35	35	11	12	M6	39	45	30	5	150	5.5		
CE25	CES25	25	60	33	2.5	60	65	40	40	14	12	M6	47	55	35	6	200	6.5		
CE30	CES30	30	70	37	5	70	70	50	50	15	18	M8	56	60	40	7	200	6.5		

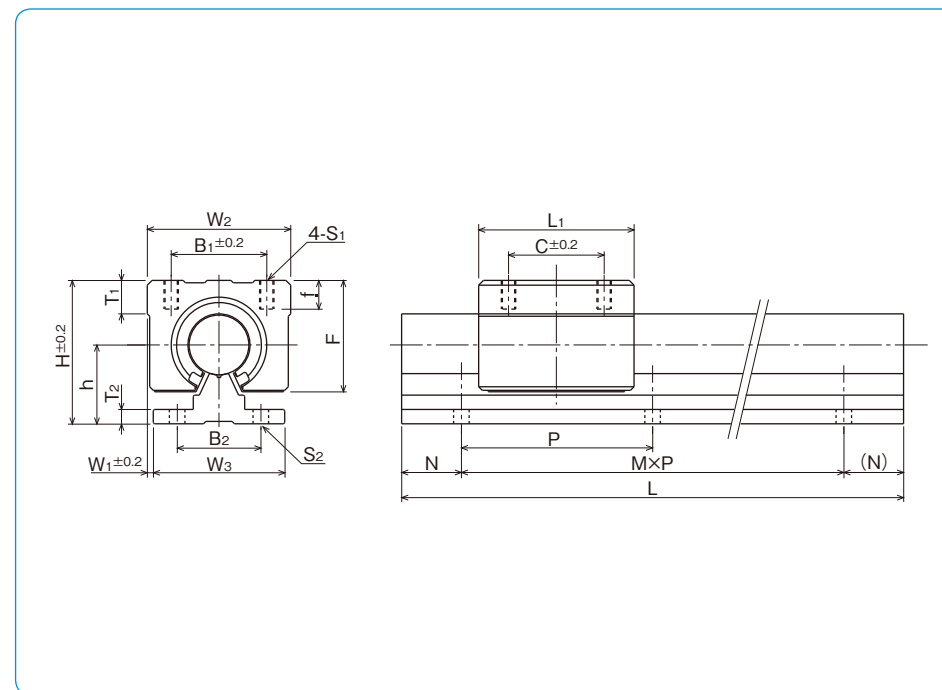

rail dimensions L (M,N) mm				basic load rating		mass		size
dynamic C N		static Co N		block g	rail kg/m			
300 (1,75)	500 (3,25)	800 (5,25)	1,000 (6,50)	774	1,180	150	2.58	16
1,500 (9,75)	1,800 (11,75)	2,000 (13,25)		882	1,370	200	3.49	20
300 (1,50)	500 (2,50)	800 (3,100)	1,000 (4,100)	980	1,570	450	5.31	25
1,500 (7,50)	1,800 (8,100)	2,000 (9,100)		1,570	2,740	630	7.39	30

1N=0.102kgf

CD TYPE

– Clearance Adjustable Type –

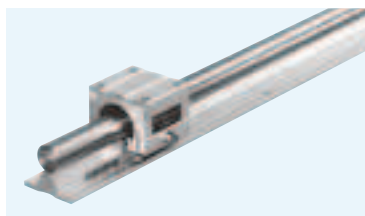

part number structure

CDS 25 - 2 - 500

specification
 CD: standard
 CDS: anti-corrosion

total length

shaft diameter

number of blocks
 attached to one shaft

※Bush inside is a resin retainer type with seals.

part number		shaft diameter mm	assembly dimensions				block dimensions										major dimensions			
standard	anti-corrosion		H	h	W ₁	W ₂	L ₁	B ₁	C	T ₁	f	S ₁	G	F	W ₃	B ₂	T ₂	P	S ₂	
CD16	CDS16	16	45	25	5	50	45	36	30	9	12	M5	6	33	40	30	5	150	5.5	
CD20	CDS20	20	50	27	4.5	54	50	40	35	11	12	M6	7	39	45	30	5	150	5.5	
CD25	CDS25	25	60	33	10.5	76	65	54	40	12	12	M6	7	47	55	35	6	200	6.5	
CD30	CDS30	30	70	37	9	78	70	58	50	15	18	M8	7	56	60	40	7	200	6.5	

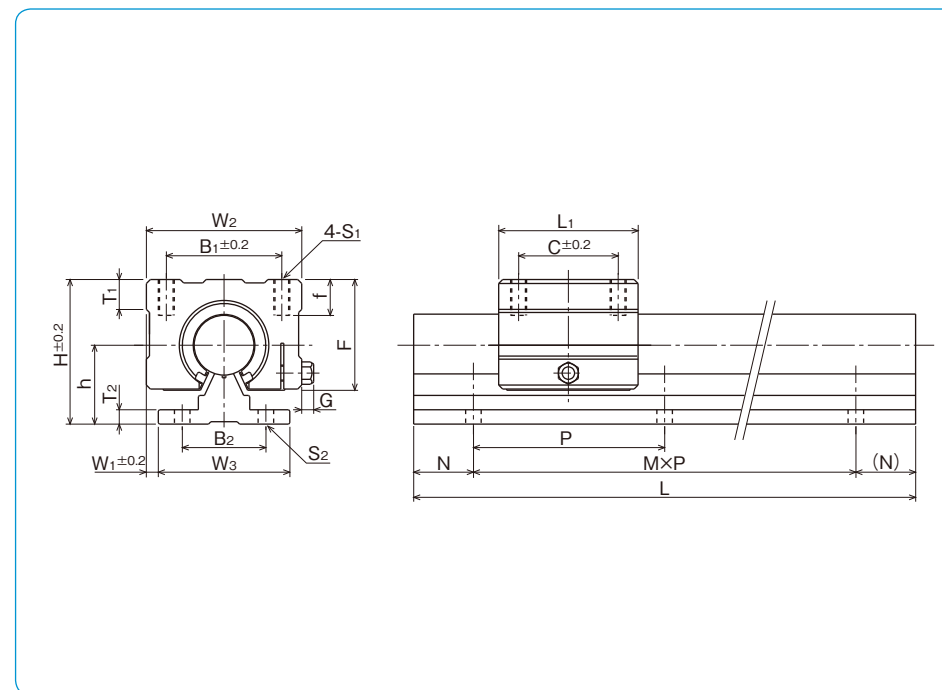

rail dimensions L (M,N) mm				basic load rating		mass		size
dynamic C N		static Co N		block g	rail kg/m			
300 (1,75)	500 (3,25)	800 (5,25)	1,000 (6,50)	774	1,180	170	2.58	16
1,500 (9,75)	1,800 (11,75)	2,000 (13,25)		882	1,370	240	3.49	20
300 (1,50)	500 (2,50)	800 (3,100)	1,000 (4,100)	980	1,570	580	5.31	25
1,500 (7,50)	1,800 (8,100)	2,000 (9,100)		1,570	2,740	720	7.39	30

1N=0.102kgf

SWA TYPE (Inch Standard)

– Block Type –

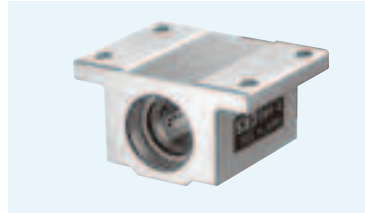

part number structure

example **SWA20GRUU**

specification
SWA: standard
SWSA: anti-corrosion

size

retainer material
blank: standard/steel
 anti-corrosion/stainless steel
G: resin

seal
blank: without seal
UU: seals on both sides

self-aligning
 (SWA-resin retainer only)

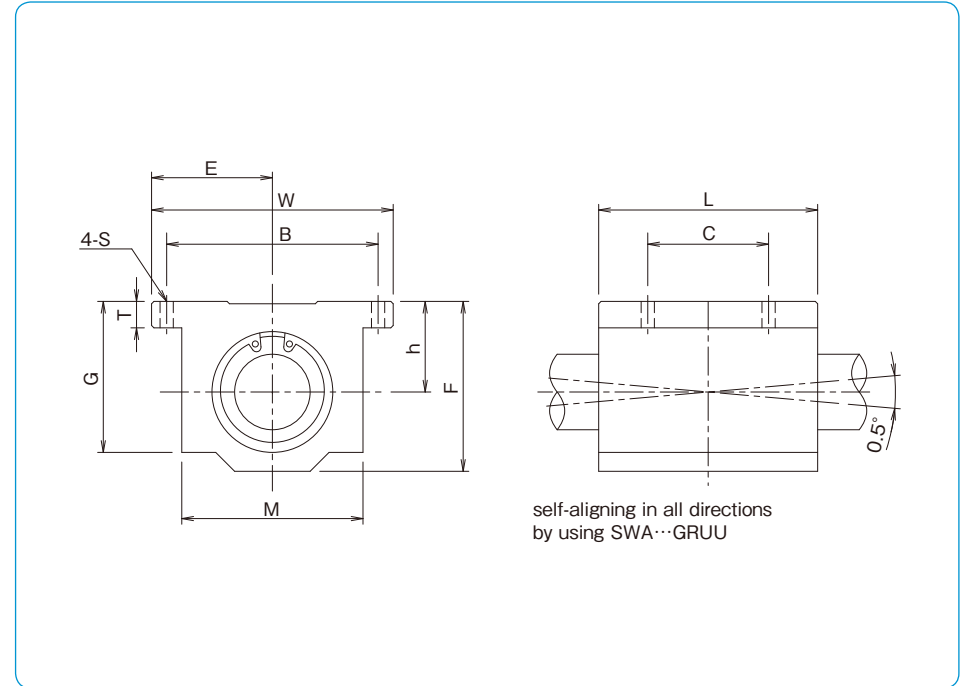

part number	inner contact diameter tolerance		major dimensions outer dimensions				
	inch/(mm)	inch/(μm)	h	E	W	L	F
			±.001/(±0.02) inch/(mm)	±.001/(±0.02) inch/(mm)	inch/(mm)	inch/(mm)	inch/(mm)
SWA 4GUU	.2500 (6.350)	0 −.00040 (−9)	.4370 (11.100)	.8125 (20.638)	1.625 (41.28)	1.188 (30.16)	.813 (20.64)
SWA 6GUU	.3750 (9.525)		.5000 (12.700)	.8750 (22.225)	1.750 (44.45)	1.313 (33.34)	.938 (23.82)
SWA 8GUU	.5000 (12.700)		.6870 (17.450)	1.0000 (25.400)	2.000 (50.80)	1.688 (42.86)	1.250 (31.75)
SWA 10GUU	.6250 (15.875)		.8750 (22.225)	1.2500 (31.750)	2.500 (63.50)	1.938 (49.21)	1.625 (41.28)
SWA 12GUU	.7500 (19.050)		.9370 (23.800)	1.3750 (34.925)	2.750 (69.85)	2.063 (52.39)	1.750 (44.45)
SWA 16GUU	1.0000 (25.400)	0 −.00040 (−10)	1.1870 (30.150)	1.6250 (41.275)	3.250 (82.55)	2.813 (71.44)	2.188 (55.56)
SWA 20GUU	1.2500 (31.750)		1.5000 (38.100)	2.0000 (50.800)	4.000 (101.60)	3.625 (92.08)	2.813 (71.44)
SWA 24GUU	1.5000 (38.100)	0 −.00050 (−12)	1.7500 (44.450)	2.3750 (60.325)	4.750 (120.65)	4.000 (101.60)	3.250 (82.55)
SWA 32GUU	2.0000 (50.800)		2.1250 (53.975)	3.0000 (76.200)	6.000 (152.40)	5.000 (127.00)	4.063 (103.19)

T	G	M	mounting dimensions			dynamic C	static Co	mass
			B	C	S			
			±.01/(±0.2) inch/(mm)	±.01/(±0.2) inch/(mm)	inch/(mm)			
.188 (4.76)	.750 (19.05)	1.000 (25.40)	1.312 (33.33)	.750 (19.05)	.156 (4.0)	206	265	45
.188 (4.76)	.875 (22.23)	1.125 (28.58)	1.437 (36.50)	.875 (22.23)	.156 (4.0)	225	314	62
.250 (6.35)	1.125 (28.58)	1.375 (34.93)	1.688 (42.88)	1.000 (25.40)	.156 (4.0)	510	784	130
.281 (7.14)	1.437 (36.50)	1.750 (44.45)	2.125 (53.98)	1.125 (28.58)	.188 (4.8)	774	1,180	240
.313 (7.94)	1.563 (39.69)	1.875 (47.63)	2.375 (60.33)	1.250 (31.75)	.188 (4.8)	862	1,370	290
.375 (9.53)	1.938 (49.21)	2.375 (60.33)	2.875 (73.03)	1.750 (44.45)	.219 (5.6)	980	1,570	615
.438 (11.11)	2.500 (63.50)	3.000 (76.20)	3.500 (88.90)	2.000 (50.80)	.219 (5.6)	1,570	2,740	1,300
.500 (12.70)	2.875 (73.03)	3.500 (88.90)	4.125 (104.78)	2.500 (63.50)	.281 (7.2)	2,160	4,020	1,900
.625 (15.88)	3.625 (92.08)	4.500 (114.30)	5.250 (133.35)	3.250 (82.55)	.406 (10.5)	3,820	7,940	3,600

SI UNIT 1N≐0.225lbf
 1kg≐2.205lbs

SWJ TYPE (Inch Standard)

– Clearance Adjustable Block Type –

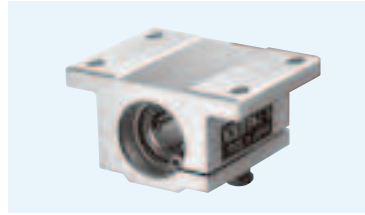

part number structure

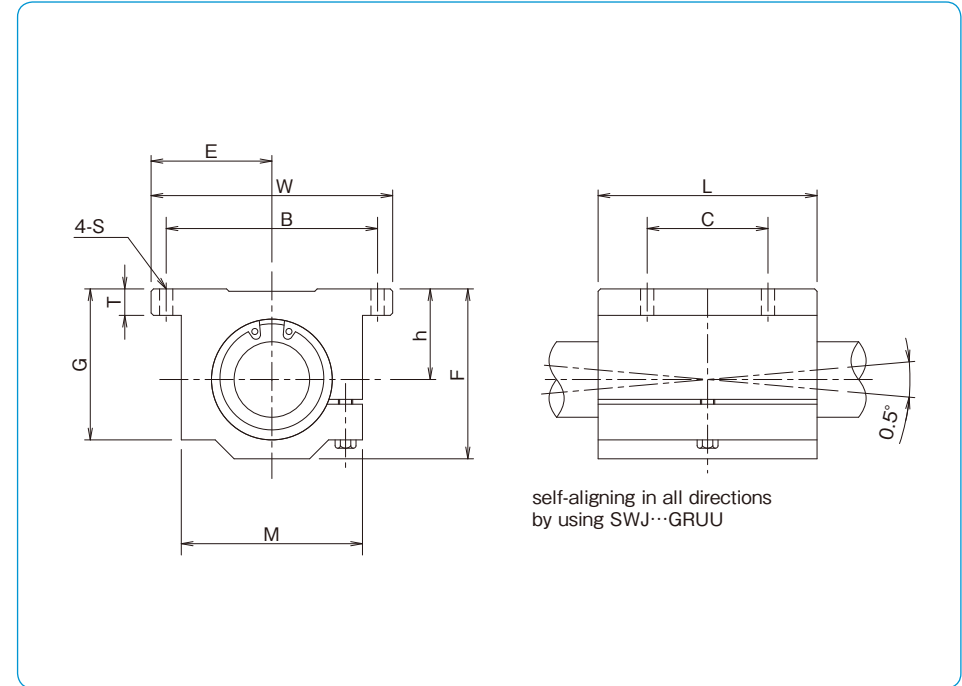
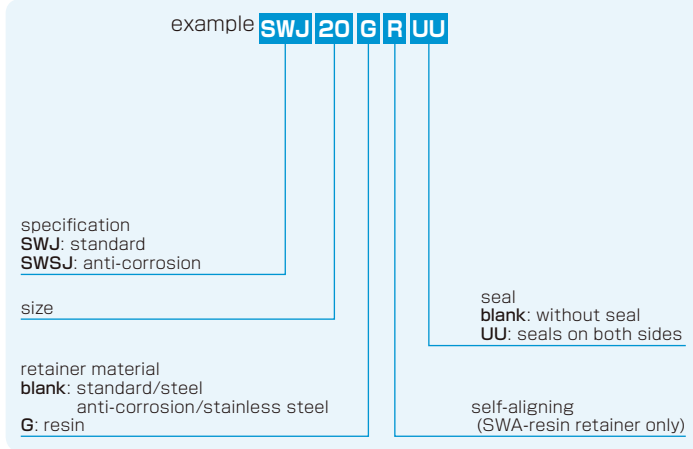

part number	inner contact diameter inch/(mm)	major dimensions outer dimensions				
		h ±.001/(±0.02) inch/(mm)	E ±.001/(±0.02) inch/(mm)	W inch/(mm)	L inch/(mm)	F inch/(mm)
SWJ 4GUU	.2500 (6.350)	.4370 (11.100)	.8125 (20.638)	1.625 (41.28)	1.188 (30.16)	.813 (20.64)
SWJ 6GUU	.3750 (9.525)	.5000 (12.700)	.8750 (22.225)	1.750 (44.45)	1.313 (33.34)	.938 (23.82)
SWJ 8GUU	.5000 (12.700)	.6870 (17.450)	1.0000 (25.400)	2.000 (50.80)	1.688 (42.86)	1.250 (31.75)
SWJ 10GUU	.6250 (15.875)	.8750 (22.225)	1.2500 (31.750)	2.500 (63.50)	1.938 (49.21)	1.625 (41.28)
SWJ 12GUU	.7500 (19.050)	.9370 (23.800)	1.3750 (34.925)	2.750 (69.85)	2.063 (52.39)	1.750 (44.45)
SWJ 16GUU	1.0000 (25.400)	1.1870 (30.150)	1.6250 (41.275)	3.250 (82.55)	2.813 (71.44)	2.188 (55.56)
SWJ 20GUU	1.2500 (31.750)	1.5000 (38.100)	2.0000 (50.800)	4.000 (101.60)	3.625 (92.08)	2.813 (71.44)
SWJ 24GUU	1.5000 (38.100)	1.7500 (44.450)	2.3750 (60.325)	4.750 (120.65)	4.000 (101.60)	3.250 (82.55)
SWJ 32GUU	2.0000 (50.800)	2.1250 (53.975)	3.0000 (76.200)	6.000 (152.40)	5.000 (127.00)	4.063 (103.19)

mounting dimensions						basic load rating		mass g
T inch/(mm)	G inch/(mm)	M inch/(mm)	B ±.01/(±0.2) inch/(mm)	C ±.01/(±0.2) inch/(mm)	S inch/(mm)	dynamic C N	static Co N	
.188 (4.76)	.750 (19.05)	1.000 (25.40)	1.312 (33.33)	.750 (19.05)	.156 (4.0)	206	265	45
.188 (4.76)	.875 (22.23)	1.125 (28.58)	1.437 (36.50)	.875 (22.23)	.156 (4.0)	225	315	62
.250 (6.35)	1.125 (28.58)	1.375 (34.93)	1.688 (42.88)	1.000 (25.40)	.156 (4.0)	510	784	130
.281 (7.14)	1.437 (36.50)	1.750 (44.45)	2.125 (53.98)	1.125 (28.58)	.188 (4.8)	774	1,180	240
.313 (7.94)	1.563 (39.69)	1.875 (47.63)	2.375 (60.33)	1.250 (31.75)	.188 (4.8)	862	1,370	290
.375 (9.53)	1.938 (49.21)	2.375 (60.33)	2.875 (73.03)	1.750 (44.45)	.219 (5.6)	980	1,570	615
.438 (11.11)	2.500 (63.50)	3.000 (76.20)	3.500 (88.90)	2.000 (50.80)	.219 (5.6)	1,570	2,740	1,300
.500 (12.70)	2.875 (73.03)	3.500 (88.90)	4.125 (104.78)	2.500 (50.80)	.281 (7.2)	2,160	4,020	1,900
.625 (15.88)	3.625 (92.08)	4.500 (114.30)	5.250 (133.35)	3.250 (82.55)	.406 (10.5)	3,820	7,940	3,600

SI UNIT 1N≒0.225lbf
1kg≒2.205lbs

SWD TYPE (Inch Standard)

– Open Block Type –

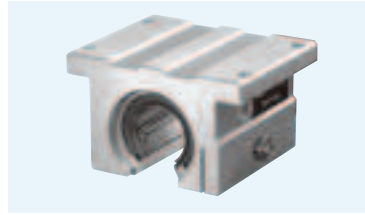

part number structure

example **SWD20GRUU**

specification
SWD: standard
SWSD: anti-corrosion

size

retainer material
blank: standard/steel
 anti-corrosion/stainless steel
G: resin

seal
blank: without seal
UU: seals on both sides

self-aligning
 (SWD-resin retainer only)

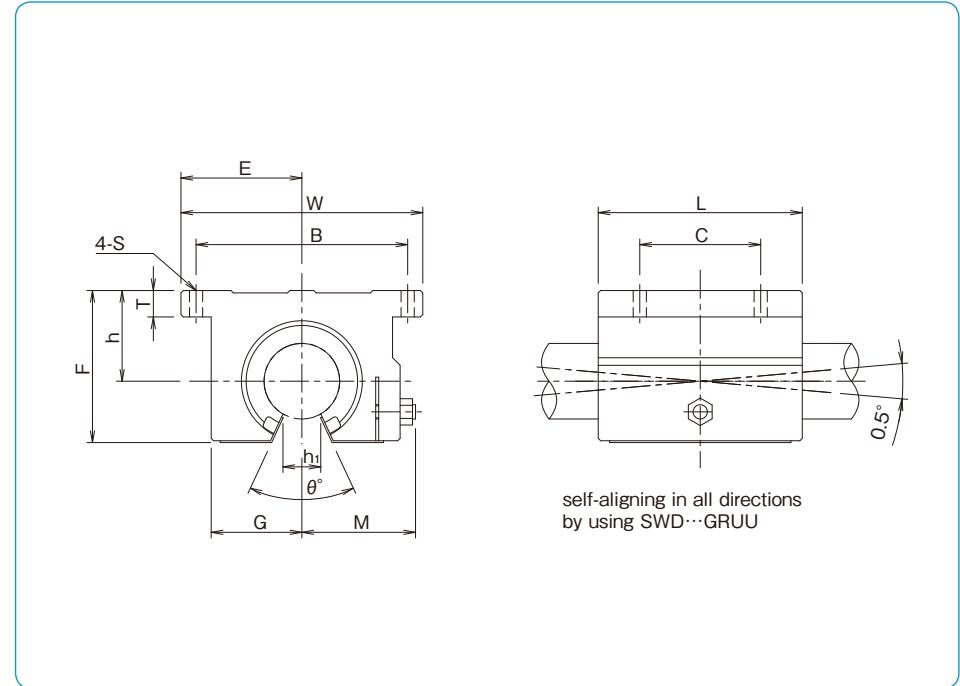

part number	inner contact diameter inch/(mm)	major dimensions						
		h ±.001/(±0.02) inch/(mm)	E ±.001/(±0.02) inch/(mm)	W inch/(mm)	L inch/(mm)	F inch/(mm)	outer dimensions T G inch/(mm) inch/(mm)	
SWD 8GUU	.5000 (12.700)	.6870 (17.450)	1.0000 (25.400)	2.000 (50.80)	1.500 (38.10)	1.100 (27.94)	.250 (6.35)	.688 (17.5)
SWD 10GUU	.6250 (15.875)	.8750 (22.225)	1.2500 (31.750)	2.500 (63.50)	1.750 (44.45)	1.375 (34.93)	.281 (7.14)	.875 (22.23)
SWD 12GUU	.7500 (19.050)	.9370 (23.800)	1.3750 (34.950)	2.750 (69.85)	1.875 (47.63)	1.535 (39.00)	.315 (8.00)	.937 (23.80)
SWD 16GUU	1.0000 (25.400)	1.1870 (30.150)	1.6250 (41.300)	3.250 (82.55)	2.625 (66.68)	1.975 (50.17)	.375 (9.53)	1.188 (30.18)
SWD 20GUU	1.2500 (31.750)	1.5000 (38.100)	2.0000 (50.800)	4.000 (101.60)	3.375 (85.73)	2.485 (63.12)	.437 (11.10)	1.500 (38.10)
SWD 24GUU	1.5000 (38.100)	1.7500 (44.450)	2.3750 (60.325)	4.750 (120.65)	3.750 (95.25)	2.910 (73.90)	.500 (12.70)	1.750 (44.45)
SWD 32GUU	2.0000 (50.800)	2.1250 (53.975)	3.0000 (76.200)	6.000 (152.4)	4.750 (120.65)	3.660 (92.90)	.625 (15.88)	2.250 (57.15)

M	h ₁	θ	mounting dimensions			dynamic C	static C ₀	mass
			B ±.01/(±0.2) inch/(mm)	C ±.01/(±0.2) inch/(mm)	S inch/(mm)			
.98 (24.89)	.3425 (8.70)	80°	1.688 (42.88)	1.000 (25.40)	.156 (4.0)	510	784	98
1.15 (29.21)	.375 (9.53)	80°	2.125 (53.98)	1.125 (28.58)	.188 (4.8)	774	1,180	185
1.23 (31.24)	.4375 (11.11)	60°	2.375 (60.33)	1.250 (31.75)	.188 (4.8)	862	1,370	235
1.48 (37.59)	.5625 (14.29)	50°	2.875 (73.03)	1.750 (44.45)	.218 (5.6)	980	1,570	530
1.88 (47.75)	.625 (15.88)	50°	3.500 (88.90)	2.000 (50.80)	.218 (5.6)	1,570	2,740	1,080
2.12 (53.85)	.750 (19.05)	50°	4.125 (104.78)	2.500 (63.50)	.281 (7.4)	2,160	4,020	1,620
2.70 (68.58)	1.00 (25.40)	50°	5.250 (133.35)	3.250 (82.55)	.406 (10.5)	3,820	7,940	3,100

SI UNIT 1N≐0.225lbf
 1kg≐2.205lbs

RBW TYPE

(Inch Standard / Anti-Corrosion Type)

— Resin Block Type —

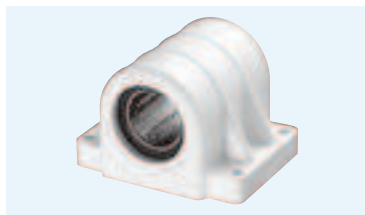

part number structure

example **RBW 16**

RBW type

size

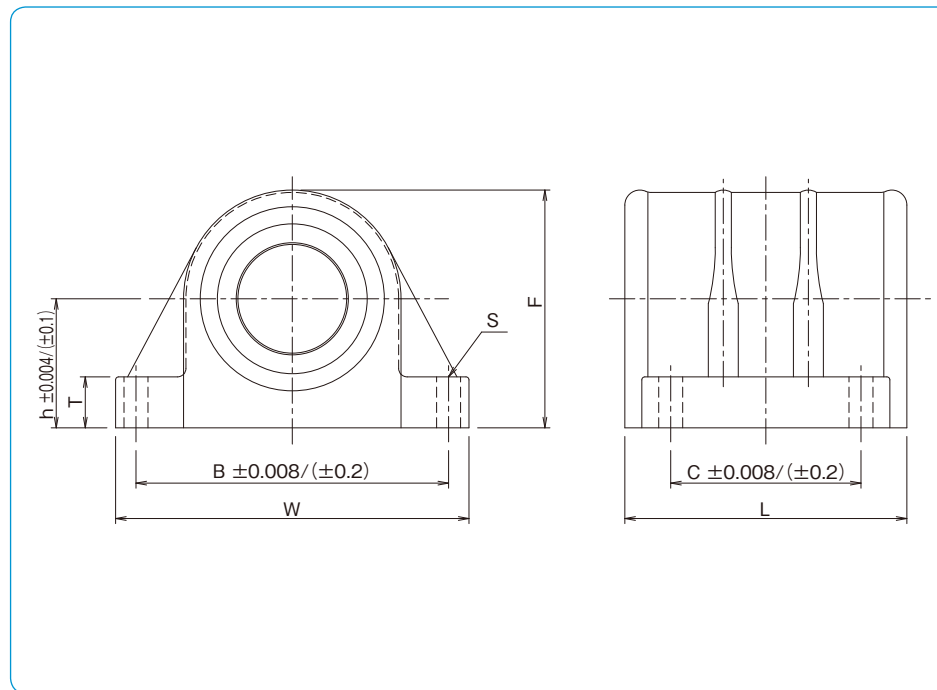

part number	inner contact diameter tolerance		major dimensions			
	inch/(mm)	inch/(μ m)	h inch/(mm)	outer dimensions W L F inch/(mm) inch/(mm) inch/(mm)		
RBW 8	.5000 (12.700)	0 -0.00040 (-9)	.6870 (17.450)	2.000 (50.80)	1.5937 (40.481)	1.2500 (31.750)
RBW 10	.6250 (15.875)		.8750 (22.225)	2.500 (63.50)	1.8437 (46.831)	1.6250 (41.275)
RBW 12	.7500 (19.050)	0 -0.00040 (-10)	.9370 (23.800)	2.750 (69.85)	1.9687 (50.006)	1.7500 (44.450)
RBW 16	1.0000 (25.400)		1.1870 (30.150)	3.250 (82.55)	2.5937 (65.881)	2.1870 (55.550)

※RBW type has side-seals as standard.

mounting dimensions				basic load rating		mass g
T inch/(mm)	B inch/(mm)	C inch/(mm)	S inch/(mm)	dynamic C N	static Co N	
.3437 (8.731)	1.688 (42.875)	1.000 (25.400)	.157 (4.0)	510	784	51
.3750 (9.525)	2.125 (53.975)	1.125 (28.575)	.189 (4.8)	774	1180	99
.4063 (10.319)	2.375 (60.325)	1.250 (31.750)	.189 (4.8)	862	1370	129
.4687 (11.906)	2.875 (73.025)	1.750 (44.450)	.220 (5.6)	980	1570	242

SI UNIT 1N≒0.225lbf
1kg≒2.205lbs