

# TRF-E TYPE

— Triple-Wide Round Flange Pilot End Type —

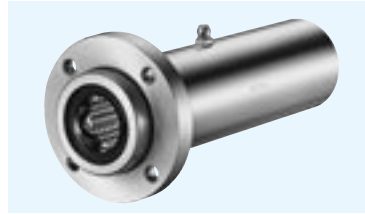

## part number structure

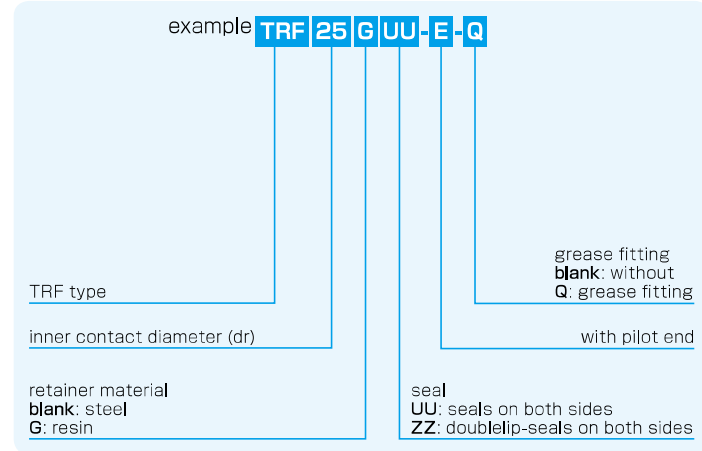

Doublelip-seal is available for size 6 to 30.

part number*		number of ball circuits	dr		major dimensions		
steel retainer	resin retainer		mm	tolerance $\mu\text{m}$	D mm	tolerance $\mu\text{m}$	L $\pm 0.3$ mm
TRF 6UU-E	TRF 6GUU-E	4	6	0	15	0/-18	51
TRF 8UU-E	TRF 8GUU-E	4	8	-12	19		66
TRF10UU-E	TRF10GUU-E	4	10		23	0	80
TRF12UU-E	TRF12GUU-E	4	12		26	-21	84
TRF13UU-E	TRF13GUU-E	4	13	0	28		90
TRF16UU-E	TRF16GUU-E	4	16	-15	32		103
TRF20UU-E	TRF20GUU-E	5	20		40	0	118
TRF25UU-E	TRF25GUU-E	6	25	0	45	-25	165
TRF30UU-E	TRF30GUU-E	6	30	-18	52		182
TRF35UU-E	TRF35GUU-E	6	35		60	0	200
TRF40UU-E	TRF40GUU-E	6	40	0	65	-30	230
TRF50UU-E	TRF50GUU-E	6	50	-21	85	0	290
TRF60UU-E	TRF60GUU-E	6	60	0/-25	100	-35	310

Outer cylinder is treated with electroless nickel plating.

\* Seals-on-both-sides is standard.

\*\* TRF6: A-MT6x1 TRF8: A-M6x1 TRF10~30: A-M6F TRF35~60: A-R1/8

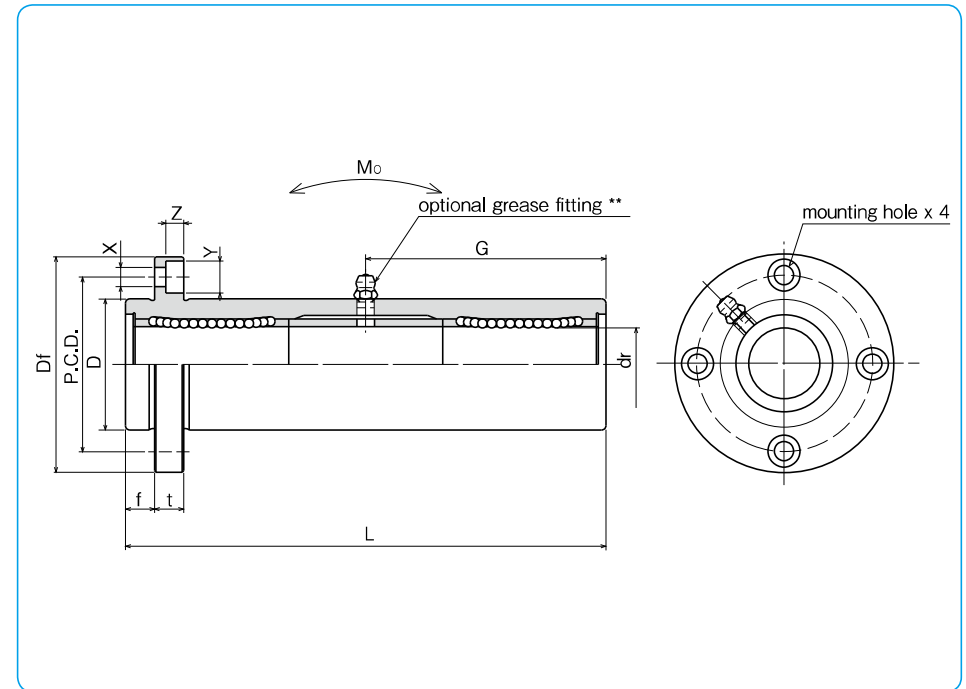

f mm	Df mm	flange			grease fitting G mm	eccentricity $\mu\text{m}$	perpendicularity $\mu\text{m}$	basic load rating			allowable static moment M <sub>o</sub> N·m	mass g	shaft diameter mm
		t mm	P.C.D. mm	X×Y×Z mm				dynamic C N	static Co N	static moment			
5	32	5	24	3.5×6×3.1	20.5	20	20	323	530	8.2	66	6	
6	40	6	29	4.5×7.5×4.1	29			431	784	16.0	135	8	
6	43	6	33	4.5×7.5×4.1	38			588	1,100	27.0	205	10	
6	46	6	36	4.5×7.5×4.1	41			813	1,570	40.1	248	12	
6	48	6	38	4.5×7.5×4.1	45			813	1,570	42.9	308	13	
8	54	8	43	5.5×9×5.1	51			1,230	2,350	73.5	412	16	
8	62	8	51	5.5×9×5.1	59	25	25	1,400	2,740	98.0	752	20	
10	74	10	60	6.6×11×6.1	82.5			1,560	3,140	157	1,244	25	
10	82	10	67	6.6×11×6.1	91			2,490	5,490	297	1,636	30	
13	96	13	78	9×14×8.1	100			2,650	6,270	373	2,580	35	
13	101	13	83	9×14×8.1	115			3,430	8,040	553	2,950	40	
18	129	18	107	11×17×11.1	145			6,080	15,900	1,370	6,860	50	
18	144	18	122	11×17×11.1	155	7,550	20,000	1,800	9,660	60			

1N≐0.102kgf 1N·m≐0.102kgf·m