

SGL-E TYPE

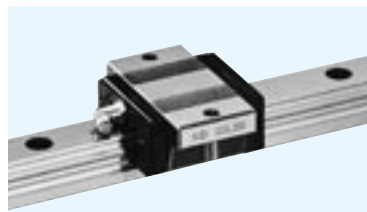

part number structure

example **SGL 15 E B 2 T1 589 D P /W2 FS LB F J KGL**

<p>SGL type</p> <p>size</p> <p>block style</p> <p>seal (refer to page A-14)</p> <p>blank: with side-seals</p> <p>B: with side-seals + under-seals</p> <p>BW: with double-seals + under-seals</p> <p>BS: B + scraper</p> <p>BR: B + reverse-seals</p> <p>number of blocks attached to one rail</p> <p>preload symbol</p> <p>blank: standard</p> <p>T1: light</p> <p>T2: medium</p> <p>total length of rail</p> <p>size of rail installation hole (D type rail is available only for SGL 15 and 30)</p>	<p>symbol for grease</p> <p>blank: standard grease</p> <p>KGL: lithium-based grease</p> <p>KGU: urea-based grease</p> <p>KGF: anti-fretting grease</p> <p>GK: K-grease</p> <p>refer to page Eng-39~</p> <p>with bellows (refer to page A-18)</p> <p>with rail mounting hole caps</p> <p>with low temperature black chrome treatment</p> <p>with Fiber Sheet</p> <p>symbol for number of axes*</p> <p>blank: single axis</p> <p>W2: 2 parallel axes</p> <p>W3: 3 parallel axes</p> <p>accuracy grade</p> <p>blank: standard</p> <p>H: high</p> <p>P: precision</p>
---	---

*The symbol for the number of axes does not mean the number of rails ordered.

part number	assembly dimensions		block dimensions											
	H	W	B	L1	L2	L3	L4	L5	P1	S1	T	b	E1	E2
	mm	mm	mm	mm	mm	mm	mm	mm	mm	mm	mm	mm	mm	mm
SGL15E SGL15E-D	24	18.5	52	40.7	22.7	46.9	47.3	54.3	41	4.5	7	19.5	6	5.4
SGL20E	28	19.5	59	47.9	29.5	54.1	54.5	65.5	49	5.5	9	22		
SGL25E	33	25	73	58.7	37.7	65.1	65.9	76.9	60	7	10	26	12	11
SGL30E SGL30E-D	42	31	90	68	40	76.6	75.6	—	72	9		32.5		
SGL35E	48	33	100	77	46	85.6	84.6	—	82		13	38		

part number	standard rail length L mm															
SGL15	160	220	280	340	400	460	520	580	640	700	760	820	880	940	1,000	1,120
SGL20	220	280	340	400	460	520	580	640	700	760	820	880	940	1,000	1,120	1,240
SGL25	220	280	340	400	460	520	580	640	700	760	820	880	940	1,000	1,120	1,240
SGL30	280	360	440	520	600	680	760	840	920	1,000	1,080	1,160	1,240	1,320	1,400	1,480
SGL35	280	360	440	520	600	680	760	840	920	1,000	1,080	1,160	1,240	1,320	1,400	1,480

Rails exceeding the maximum specified length may be fabricated if joints are used. Please contact NB for assistance.

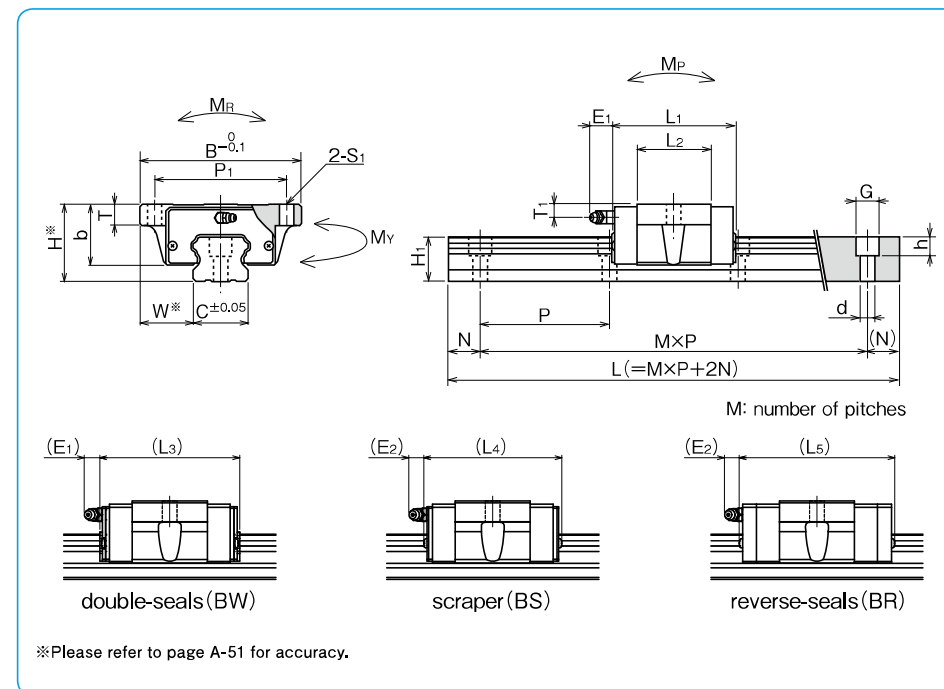

*Please refer to page A-51 for accuracy.

T1	grease fitting	guide rail dimensions				basic load rating		allowable static moment			mass		block size	
		H1	C	d × G × h	N	P	dynamic C	static Co	MP	MY	MR	block		guide rail
mm		mm	mm	mm	mm	mm	kN	kN	N · m	N · m	N · m	kg	kg/m	
5	pressed fitting	13.5	15	3.5 × 6 × 4.5 4.5 × 7.5 × 5.3			7.29	9.45	36.7 252	36.7 252	73.9	0.1	1.3	15
6	B-M6F	16	20	6 × 9.5 × 8.5		60	11.9	14.8	71.9 447	71.9 447	159	0.2	2.1	20
6.5		20	23	7 × 11 × 9	20	80	17.0	21.1	123 751	123 751	254	0.4	3.0	25
9		24	28	7 × 11 × 9 9 × 14 × 12			23.0	28.7	195 1,260	195 1,260	417	0.6	4.6	30
8.5		27.5	34	9 × 14 × 12			32.0	37.8	293 1,870	293 1,870	693	0.9	6.2	35

M_P and M_Y are allowable static moments when two blocks are used in close contact. 1kN ≒ 102kgf 1N · m ≒ 0.102kgf · m

	maximum length mm
1,240 1,360 1,480	2,000
1,360 1,480 1,600 1,660 1,720 1,840 1,960	3,000
1,360 1,480 1,600 1,660 1,720 1,840 1,960	3,000
1,640 1,720 1,800 1,880 1,960	3,000
1,640 1,720 1,800 1,880 1,960	3,000