

SGL-HYF TYPE

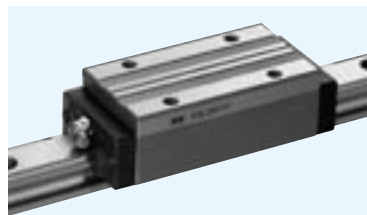

part number structure

example **SGL15HYFB2T1-589P/W2FSLBFJKGL**

<p>example</p> <p>SGL type</p> <p>size</p> <p>block style</p> <p>seal (refer to page A-14)</p> <p>blank: with side-seals</p> <p>B: with side-seals + under-seals</p> <p>BW: with double-seals + under-seals</p> <p>BS: B + scraper</p> <p>BR: B + reverse-seals</p> <p>number of blocks attached to one rail</p> <p>preload symbol</p> <p>blank: standard</p> <p>T1: light</p> <p>T2: medium</p> <p>total length of rail</p>	<p>symbol for grease</p> <p>blank: standard grease</p> <p>KGL: lithium-based grease</p> <p>KGU: urea-based grease</p> <p>KGF: anti-fretting grease</p> <p>GK: K-grease</p> <p>refer to page Eng-39~</p> <p>with bellows (refer to page A-18)</p> <p>with rail mounting hole caps</p> <p>with low temperature black chrome treatment</p> <p>with Fiber Sheet</p> <p>symbol for number of axes*</p> <p>blank: single axis</p> <p>W2: 2 parallel axes</p> <p>W3: 3 parallel axes</p> <p>accuracy grade</p> <p>blank: standard</p> <p>H: high</p> <p>P: precision</p>
--	---

*The symbol for the number of axes does not mean the number of rails ordered.

part number	assembly dimensions		block dimensions													
	H	W	B	L1	L2	L3	L4	L5	P1	P2	S1	f	T	b	E1	E2
	mm	mm	mm	mm	mm	mm	mm	mm	mm	mm	mm	mm	mm	mm	mm	mm
SGL15HYF	28	9.5	34	79	61	85.2	85.6	92.6	26	26	M4	5	6	23.7	6	5.4
SGL20HYF	30	12	44	96	77.6	102.2	102.6	113.6	32	50	M5	6	9.5	24	12	11
SGL25HYF	40	12.5	48	109	88	115.4	116.2	127.2	35		M6	8	9	33		
SGL30HYF	45	16	60	129	101	137.6	136.6	-	40	60	M8	10	13	35.5		
SGL35HYF	55	18	70	147	116	155.6	154.6	-	50	72		12	15	45		
SGL45HYF	70	20.5	86	171	134	179.5	180	-	60	80	M10	17	15	60	15	15

part number	standard rail length															
	L mm															
SGL15	160	220	280	340	400	460	520	580	640	700	760	820	880	940	1,000	1,120
SGL20	220	280	340	400	460	520	580	640	700	760	820	880	940	1,000	1,120	1,240
SGL25	220	280	340	400	460	520	580	640	700	760	820	880	940	1,000	1,120	1,240
SGL30	280	360	440	520	600	680	760	840	920	1,000	1,080	1,160	1,240	1,320	1,400	1,480
SGL35	280	360	440	520	600	680	760	840	920	1,000	1,080	1,160	1,240	1,320	1,400	1,480
SGL45	570	675	780	885	990	1,095	1,200	1,305	1,410	1,515	1,620	1,725	1,830	1,935	2,040	2,145

Rails exceeding the maximum specified length may be fabricated if joints are used. Please contact NB for assistance.

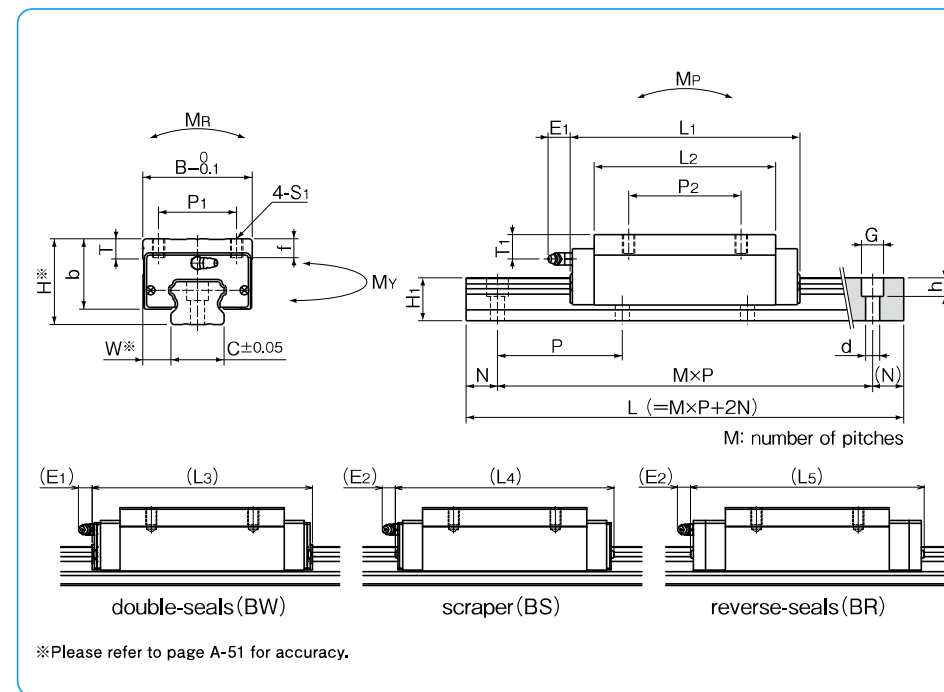

*Please refer to page A-51 for accuracy.

T1	grease fitting	guide rail dimensions				basic load rating		allowable static moment			mass		block size			
		H1	C	d × G × h	N	P	dynamic C	static Co	MP	MY	MR	block		guide rail		
mm		mm	mm	mm	mm	mm	kN	kN	N · m	N · m	N · m	kg	kg/m			
9	pressed fitting	13.5	15	4.5 × 7.5 × 5.3	20	60	14.6	25.6	238	1,200	200	0.3	1.3	15		
8	B-M6F	16	20	6 × 9.5 × 8.5			23.9	40.2	467	2,250	467	2,250	432	0.5	2.1	20
13.5		20	23	7 × 11 × 9	32.8	54.5	723	3,480	723	3,480	655	0.9	3.0	25		
12		24	28	9 × 14 × 12	44.6	73.8	1,140	5,680	1,140	5,680	1,070	1.3	4.6	30		
15.5		27.5	34		61.9	97.2	1,720	8,480	1,720	8,480	1,780	2.2	6.2	35		
20	B-PT1/8	36.5	45	14 × 20 × 17	22.5	105	91.4	134	2,680	13,300	2,680	13,300	3,080	4.0	10.5	45

M₂ and M_{Y2} are allowable static moments when two blocks are used in close contact. 1kN ≅ 102kgf 1N · m ≅ 0.102kgf · m

							maximum length	
							mm	
1,240	1,360	1,480					2,000	
1,360	1,480	1,600	1,660	1,720	1,840	1,960	3,000	
1,360	1,480	1,600	1,660	1,720	1,840	1,960	3,000	
1,640	1,720	1,800	1,880	1,960			3,000	
1,640	1,720	1,800	1,880	1,960			3,000	
2,250	2,355	2,460	2,565	2,670	2,775	2,880	2,985	3,000