

SGL-HTF TYPE

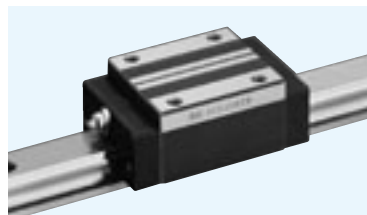

part number structure

example **SGL 15 HTF B 2 T1 - 589 P / W2 FS LB F J - KGL**

<p>SGL type</p> <p>size</p> <p>block style</p> <p>seal (refer to page A-14)</p> <p>blank: with side-seals</p> <p>B: with side-seals + under-seals</p> <p>BW: with double-seals + under-seals</p> <p>BS: B + scraper</p> <p>BR: B + reverse-seals</p> <p>number of blocks attached to one rail</p> <p>preload symbol</p> <p>blank: standard</p> <p>T1: light</p> <p>T2: medium</p> <p>total length of rail</p>	<p>symbol for grease</p> <p>blank: standard grease</p> <p>KGL: lithium-based grease</p> <p>KGU: urea-based grease</p> <p>KGF: anti-fretting grease</p> <p>KG: K-grease</p> <p>refer to page Eng-39~</p> <p>with bellows (refer to page A-18)</p> <p>with rail mounting hole caps</p> <p>with low temperature black chrome treatment</p> <p>with Fiber Sheet</p> <p>symbol for number of axes*</p> <p>blank: single axis</p> <p>W2: 2 parallel axes</p> <p>W3: 3 parallel axes</p> <p>accuracy grade</p> <p>blank: standard</p> <p>H: high</p> <p>P: precision</p>
---	---

*The symbol for the number of axes does not mean the number of rails ordered.

part number	assembly dimensions		block dimensions													
	H	W	B	L ₁	L ₂	L ₃	L ₄	L ₅	P ₁	P ₂	S ₁	f	T	b	E ₁	E ₂
	mm	mm	mm	mm	mm	mm	mm	mm	mm	mm	mm	mm	mm	mm	mm	mm
SGL15HTF	28	9.5	34	56.5	38.5	62.7	63.1	70.1	26	26	M4	5	6	23.7	6	5.4
SGL20HTF	30	12	44	71.6	53.2	77.8	78.2	89.2	32	36	M5	6	9.5	24	12	11
SGL25HTF	40	12.5	48	80	59	86.4	87.2	98.2	35	35	M6	8	9	33	12	11
SGL30HTF	45	16	60	95.7	67.7	104.3	103.3	—	40	40	M8	10	13	35.5	15	15
SGL35HTF	55	18	70	109	78	117.6	116.6	—	50	50		12	15	45	15	15
SGL45HTF	70	20.5	86	139	102	147.5	148	—	60	60	M10	17	15	60	15	15

part number	standard rail length															
	L mm															
SGL15	160	220	280	340	400	460	520	580	640	700	760	820	880	940	1,000	1,120
SGL20	220	280	340	400	460	520	580	640	700	760	820	880	940	1,000	1,120	1,240
SGL25	220	280	340	400	460	520	580	640	700	760	820	880	940	1,000	1,120	1,240
SGL30	280	360	440	520	600	680	760	840	920	1,000	1,080	1,160	1,240	1,320	1,400	1,480
SGL35	280	360	440	520	600	680	760	840	920	1,000	1,080	1,160	1,240	1,320	1,400	1,480
SGL45	570	675	780	885	990	1,095	1,200	1,305	1,410	1,515	1,620	1,725	1,830	1,935	2,040	2,145

Rails exceeding the maximum specified length may be fabricated if joints are used. Please contact NB for assistance.

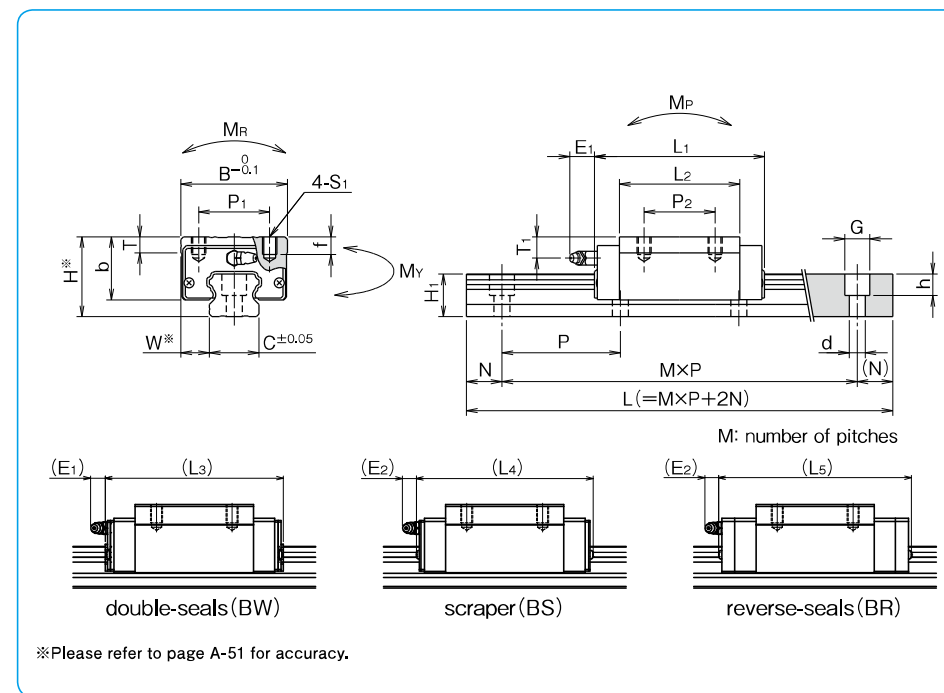

T ₁	grease fitting	guide rail dimensions				basic load rating		allowable static moment			mass		block size	
		H ₁	C	d × G × h	N	P	dynamic C	static C ₀	M _P	M _Y	M _R	block		guide rail
mm		mm	mm	mm	mm	mm	kN	kN	N · m	N · m	N · m	kg	kg/m	
9	pressed fitting	13.5	15	4.5 × 7.5 × 5.3	20	60	10.6	16.2	99.5 565	99.5 565	126	0.2	1.3	15
8	B-M6F	16	20	6 × 9.5 × 8.5			18.3	27.5	226 1,180	226 1,180	296	0.4	2.1	20
13.5		20	23	7 × 11 × 9	24.7	36.3	334 1,740	334 1,740	437	0.6	3.0	25		
12		24	28	9 × 14 × 12	33.6	49.2	528 2,880	528 2,880	716	0.9	4.6	30		
15.5		27.5	34		46.6	64.8	796 4,290	796 4,290	1,180	1.5	6.2	35		
20	B-PT1/8	36.5	45	14 × 20 × 17	22.5	105	74.7	101	1,550 8,250	1,550 8,250	2,310	3.1	10.5	45

M_{P2} and M_{Y2} are allowable static moments when two blocks are used in close contact. 1kN ≒ 102kgf 1N · m ≒ 0.102kgf · m

				maximum length
				mm
1,240	1,360	1,480		2,000
1,360	1,480	1,600	1,660 1,720 1,840 1,960	3,000
1,360	1,480	1,600	1,660 1,720 1,840 1,960	3,000
1,640	1,720	1,800	1,880 1,960	3,000
1,640	1,720	1,800	1,880 1,960	3,000
2,250	2,355	2,460	2,565 2,670 2,775 2,880 2,985	3,000